



# S-Series Brushless, Frameless Torque Motor

## HARDWARE MANUAL

Revision 3.02



# GLOBAL TECHNICAL SUPPORT

Go to the [Global Technical Support Portal](#) for information and support about your Aerotech, Inc. products. The website supplies software, product manuals, Help files, training schedules, and PC-to-PC remote technical support. If necessary, you can complete Product Return (RMA) forms and get information about repairs and spare or replacement parts. To get help immediately, contact a service office or your sales representative. Include your customer order number in your email or have it available before you call.

This manual contains proprietary information and may not be reproduced, disclosed, or used in whole or in part without the express written permission of Aerotech, Inc. Product names mentioned herein are used for identification purposes only and may be trademarks of their respective companies.

Copyright © 2000-2025, Aerotech, Inc. | All rights reserved.

See the latest version of Aerotech's [Terms of Use](#), [Privacy Policy](#), and [Cookie Policy](#) online at [aerotech.com](http://aerotech.com).



## Table of Contents

<b>S-Series Brushless, Frameless Torque Motor</b> .....	<b>1</b>
Table of Contents .....	3
List of Figures .....	4
List of Tables .....	5
EU Declaration of Conformity .....	7
UKCA Declaration of Conformity .....	8
Safety Procedures and Warnings .....	9
Installation and Operation .....	10
Electrical Warnings .....	11
Motor-Related Warnings .....	12
Pinch Points .....	13
Handling and Storage .....	14
<b>Chapter 1: Overview</b> .....	<b>17</b>
1.1. Motor Specifications .....	18
1.2. Dimensions .....	28
1.3. Environmental Specifications .....	33
1.4. Vacuum Operation .....	33
<b>Chapter 2: Assembly and Installation</b> .....	<b>35</b>
2.1. Stator Housing Requirements .....	35
2.2. Rotor Shaft Requirements .....	36
2.3. Motor Assembly .....	37
2.4. Hall Card Placement .....	38
2.5. External Motor Wiring .....	40
2.5.1. Motor Power Conductors .....	40
2.5.2. Protective Ground .....	40
2.5.3. Over-Current Protection .....	40
2.5.4. Hall-Effect Device and Thermistor Wiring .....	41
2.5.5. Wiring Guidelines .....	41
2.5.6. Thermal Protective Device .....	42
2.6. Motor Heating .....	44
<b>Chapter 3: Maintenance</b> .....	<b>45</b>
<b>Appendix A: Warranty and Field Service</b> .....	<b>47</b>
<b>Appendix B: Revision History</b> .....	<b>49</b>
<b>Index</b> .....	<b>51</b>

## List of Figures

Figure 1-1: Torque Speed Curves (S-50-XX) .....	19
Figure 1-2: Torque Speed Curves (S-76-XX) .....	21
Figure 1-3: Torque Speed Curves (S-130-XX) .....	23
Figure 1-4: Torque Speed Curves (S-180-XX) .....	25
Figure 1-5: Torque Speed Curves (S-240-XX) .....	27
Figure 1-6: S-50 Dimensions .....	28
Figure 1-7: S-76 Dimensions .....	29
Figure 1-8: S-130 Dimensions .....	30
Figure 1-9: S-180 Dimensions .....	31
Figure 1-10: S-240 Dimensions .....	32
Figure 2-1: Motor Mounting Using Stator and Rotor Clamp Rings .....	36
Figure 2-2: Motor Mounting Using Direct Bolting of the Rotor to the Shaft .....	36
Figure 2-3: Hall Board Placement .....	38
Figure 2-4: Motor BEMF and Hall Signal Relationship .....	39
Figure 2-5: Thermal Sensor Resistance as a Function of Temperature .....	42
Figure 2-6: Typical Thermistor Interface Circuit .....	43
Figure 2-7: Operating Regions Example .....	44

**List of Tables**

Table 1-1: Frameless Torque Motor Options .....	17
Table 1-2: S-50 Motor Specifications .....	18
Table 1-3: S-76 Motor Specifications .....	20
Table 1-4: S-130 Motor Specifications .....	22
Table 1-5: S-180 Motor Specifications .....	24
Table 1-6: S-240 Motor Specifications .....	26
Table 1-7: Environmental Specifications .....	33
Table 2-1: Connector Wire Gauge .....	40

*This page intentionally left blank.*

## EU Declaration of Conformity

**Manufacturer** Aerotech, Inc.  
**Address** 101 Zeta Drive  
Pittsburgh, PA 15238-2811  
USA



Declares that the product:

**Product** S-Series Motors  
**Model/Types** All

To which this declaration relates, meets the essential health and safety requirements and is in conformity with the relevant EU Directives listed below:

2014/35/EU Low Voltage Directive  
EU 2015/863 Directive, Restricted Substances (RoHS 3)

Using the relevant section of the following EU Standards and other normative documents:

IEC 61010-1:2010 Safety requirements for electrical equipment for measurement, control, and laboratory use

**NOTE:** Safe operation of the motor requires over speed and over current protection. This could be done by the connected controller / amplifier combination.

**Authorized Representative:**

Managing Director  
Aerotech GmbH  
Gustav-Weißkopf-Str. 18  
90768 Fürth  
Germany

A handwritten signature in black ink, appearing to read 'Jochen Jäger', written over a horizontal line.

Jochen Jäger

**Engineer Verifying Compliance:**

Aerotech, Inc.  
101 Zeta Drive  
Pittsburgh, PA 15238-2811  
USA

A handwritten signature in black ink, appearing to read 'Matt Maurer', written over a horizontal line.

Matt Maurer

Date: 2/18/2025

## UKCA Declaration of Conformity

**Manufacturer** Aerotech, Inc.  
**Address** 101 Zeta Drive  
Pittsburgh, PA 15238-2811  
USA



Declares that the product:

**Product** S-Series Motors  
**Model/Types** All

To which this declaration relates, meets the essential health and safety requirements and is in conformity with the relevant UK Legislation listed below:

Electrical Equipment (Safety) Regulations 2016  
Hazardous Substances in Electrical and Electronic Equipment Regulations 2012

Using the relevant section of the following UK Designated Standards and other normative documents when installed in accordance with the installation instructions supplied by the manufacturer.

IEC 61010-1:2010 Safety requirements for electrical equipment for measurement, control, and laboratory use

**NOTE:** Safe operation of the motor requires over speed and over current protection.  
This could be done by the connected controller / amplifier combination.

**Authorized Representative:**

Managing Director  
Aerotech Ltd  
The Old Brick Kiln  
Ramsdell, Tadley  
Hampshire RG26 5PR  
UK

A handwritten signature in black ink, appearing to read 'Simon Smith', is written above a horizontal line.

Simon Smith

**Engineer Verifying Compliance:**

Aerotech, Inc.  
101 Zeta Drive  
Pittsburgh, PA 15238-2811  
USA  
Date: 2/18/2025

A handwritten signature in black ink, appearing to read 'Matt Maurer', is written above a horizontal line.

Matt Maurer



## Safety Procedures and Warnings



**IMPORTANT:** This manual tells you how to carefully and correctly use and operate the motor.

- Read all parts of this manual before you install or operate the motor or before you do maintenance to your system.
- To prevent injury to you and damage to the equipment, obey the precautions in this manual.
- All specifications and illustrations are for reference only and were complete and accurate as of the release of this manual. To find the newest information about this product, refer to [www.aerotech.com](http://www.aerotech.com).

If you do not understand the information in this manual, contact Aerotech Global Technical Support.



**IMPORTANT:** This product has been designed for light industrial manufacturing or laboratory environments. If the product is used in a manner not specified by the manufacturer:

- The protection provided by the equipment could be impaired.
- The life expectancy of the product could be decreased.

Safety notes and symbols are placed throughout this manual to warn you of the potential risks at the moment of the safety note or if you fail to obey the safety note.



Shock/Electrocution Hazard



Pinch, Shear, or Crush Hazard



General/Conditional Awareness



Rotational Machinery Hazard



Hot Surface Hazard



Pinch/Entanglement Hazard



Magnetic Field Hazard



Trip Hazard



Heavy, Bulky Lifting Hazard



Appropriate Equipment Required



Pressure/Explosive Atmosphere Hazard



Electrostatic Discharge Hazard

A blue circle symbol is an action or tip that you should obey. Some examples include:



General tip



Read the manual/section



Wear personal protective equipment (PPE): Safety Glasses



If applicable, do not lift unassisted



Wear personal protective equipment (PPE): Gloves



Wear personal protective equipment (PPE): Hearing Protection

## Installation and Operation

To decrease the risk of damage to the equipment, you must obey the precautions that follow.



**IMPORTANT:** Aerotech motors are meant to be part of a drive package that consists of an amplifier and a controller. The motor relies on the drive package for fault protection. Do not use these motors in any other way.



### **DANGER: General Hazard Warning!**

This product can produce high forces and move at velocities that could cause injury. The user is responsible for its safe operation. The following general equation is provided to assist with risk assessments in regards to contact and pinch points:

$$Pressure_{Max} \left[ \frac{N}{mm^2} \right] = \frac{Force_{Peak} [N]}{Area_{Contact} [mm^2]}$$



### **WARNING: General Hazard Warning!**

- Only trained operators should operate this equipment.
- All service and maintenance must be done by approved personnel.
- Use this product only in environments and operating conditions that are approved in this manual.
- Never install or operate equipment that appears to be damaged.
- Make sure that the product is securely mounted before you operate it.
- Use care when you move the motor or you could negatively affect the performance of it.



### **WARNING: Trip Hazard!**

Route, house, and secure all cables, duct work, air, or water lines. Failure to do so could introduce trip hazards around the system that could result in physical injury or could damage the equipment.

## Electrical Warnings

To decrease the risk of electrical shock, injury, death, and damage to the equipment, obey the precautions that follow.



### **DANGER: Electrical Shock Hazard!**

- Motor phase voltage levels could be hazardous live.
- Restrict user access to the motor coil and wires while the motor is powered.
  - The enclosure around the operating components should remove power to the drive when the enclosure is opened.
  - The motor can also be contained in a grounded mechanical system (positioning stage) that will prevent direct access to the high voltage motor components.
- Personnel are protected from hazardous voltages unless electrical interconnections, protective bonding (safety ground), or motor enclosures are compromised.
- Do not connect or disconnect motor interconnections while connected to a live electrical power source.
- Before you set up or do maintenance, disconnect electrical power.
- Make sure that the motor frame is safety grounded with a conductor equal in size to the phase conductors.
- The drive must contain a properly-sized fuse, matched to the motor cable wire size.
- It is the responsibility of the End User/System Integrator to make sure that motors are properly connected and grounded per Engineering Standards and applicable safety requirements.
- It is the responsibility of the End User/System Integrator to configure the system drive or controller within the Aerotech motor electrical and mechanical specifications.

## Motor-Related Warnings

Aerotech motors are capable of producing high forces and velocities. Obey all warnings and all applicable codes and standards when you use or operate a stage or system that incorporates Aerotech motors.

### **DANGER: Mechanical Hazard!**



Personnel must be made aware of the mechanical hazards during set up or when you do service to the motor.

- Unintentional manual movement into the stage "end-of-travel" stops, could damage the stage or undo precision alignments.
- Motor movement could create pinch points, entanglement hazards, or rotational mechanical hazards.
- Uncouple or otherwise prevent motion of motor-coupled machinery when you do service to the equipment.

### **DANGER: Hot Surface Hazard!**



- The motor frame temperature could exceed 70°C in some applications.
- Do not touch the motor frame while it is in operation.
- Wait until the motor has cooled before you touch it.

### **DANGER: Risk of Explosive Atmosphere!**



- Standard Aerotech motors are not rated for applications with explosive atmospheres such as airborne dust or combustible vapors.
- Do not operate motors outside of Aerotech environmental specifications.

### **DANGER: Magnetic Field Hazard!**



Aerotech motors contain magnets which can present a Magnetic Field Hazard.

- Do not disassemble a motor under any circumstances.
- Strong magnetic fields could interfere with external/internal medical devices.
- Strong magnetic fields could present mechanical hazards such as pinch points.

## Pinch Points

A pinch point is a mechanical hazard that can occur when there are exposed parts of the motor, stage, or system that can move. For example, the travel of a stage tabletop could expose the user to a pinch point between the tabletop and the stage housing. The images that follow will show you typical external and internal pinch point locations.

**DANGER: Mechanical Hazard!**

- System travel can cause crush, shear, or pinch injuries.
- Only trained operators should operate this equipment.
- Do not put yourself in the travel path of machinery.
- Restrict access to all motor parts
  - when the system moves under power (during normal operation, for example).
  - when the system is moved manually (during the installation process or when you do maintenance, for example).
- Motors are capable of very high speeds and acceleration rates.

**Figure 1: Typical Pinch Point Locations**

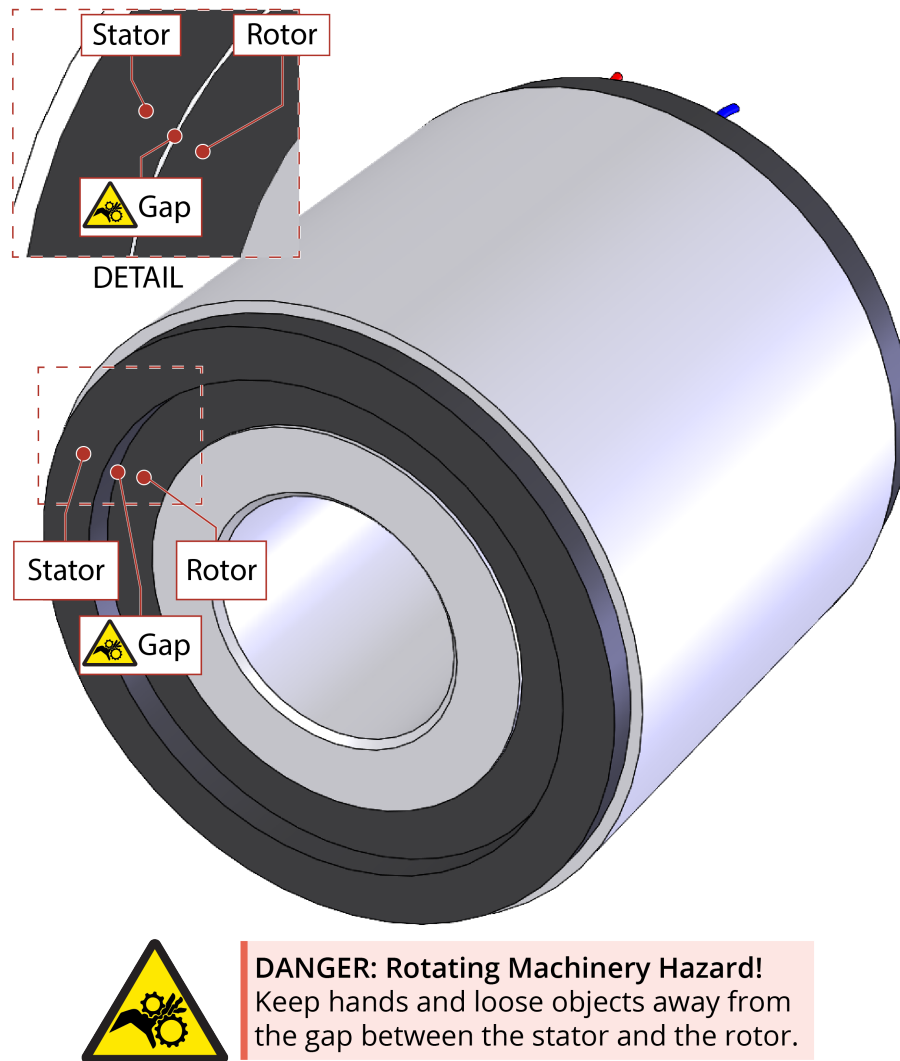

**DANGER: Rotating Machinery Hazard!**  
Keep hands and loose objects away from the gap between the stator and the rotor.

## Handling and Storage



**IMPORTANT:** It is the responsibility of the customer to safely and carefully lift and move the motor.

- Be careful when you move or transport the motor.
- Retain the shipping materials for future use.
- Transport or store the motor in its protective packaging.



### **WARNING: Electrostatic Discharge (ESD) Sensitive Components!**

Wear an ESD wrist strap when you handle, install, or do service to the system assembly.

Failure to observe the correct ESD practices could cause ESD damage to stage electronics, system drives, and/or power supplies.

Inspect the shipping container for any evidence of shipping damage. If any damage exists, notify the shipping carrier immediately.

Remove the packing list from the shipping container. Make sure that all the items specified on the packing list are contained within the package.

The documentation for the motor is on the included installation device. The documents include manuals, interconnection drawings, and other system documentation. Save this information for future reference.

Each motor has a label listing the system part number and serial number. These numbers contain information necessary for maintenance or system hardware and software updates. Locate this label and record the information for later reference.

## Unpacking and Handling

It is the responsibility of the customer to safely and carefully lift and move the motor.



**IMPORTANT:** All electronic equipment and instrumentation is wrapped in antistatic material and packaged with desiccant. Ensure that the antistatic material is not damaged during unpacking.



**DANGER: Lifting Hazard!** Use care when you move the motor or you could negatively affect the performance of it.

- Use the correct lifting techniques, mechanical assistance, or additional help to lift or move this product.
- Do not use the cables or the connectors to lift or move this product.
- Make sure that all moving parts are secure before you move the motor. Unsecured moving parts could shift and cause injury or damage to the equipment.
- If the motor is heavy, a single person lift could cause injury. Use assistance when you lift or move it.
  - Refer to [Section 1.2. Dimensions](#) for dimensions
  - Refer to [Section 1.1. Motor Specifications](#) for weight specifications.

Carefully remove the motor from its protective shipping container.

- Lift this product only by the base.
- Use a cart, dolly, or similar device to move the motor to a new location.

Gently set the motor on a smooth, flat, and clean surface. Use compressed nitrogen or clean, dry, oil-free air to remove any dust or debris that has collected during shipping.

Before you operate the motor, let it stabilize at room temperature for at least 12 hours. This will ensure that all of the alignments, preloads, and tolerances are the same as they were when they were tested at Aerotech.

**Storage**

Store the motor in the original shipping container. If the original packaging included ESD protective packaging, make sure to store the motor in it. The storage location must be dry, free of dust, free of vibrations, and flat.

Refer to [Section 1.3. Environmental Specifications](#)

*This page intentionally left blank.*



## Chapter 1: Overview

S-Series motors include the stator with flying leads, adjustable-phase Hall board, and rotor with magnets. Custom models are available. Contact Aerotech for more information.

**Table 1-1: Frameless Torque Motor Options**

Option	Slotless Motor, Rotor, and Stator
S-50-39	50 mm O.D., 39 mm length
S-50-52	50 mm O.D., 52 mm length
S-50-86	50 mm O.D., 86 mm length
S-76-35	76 mm O.D., 35 mm length
S-76-85	76 mm O.D., 85 mm length
S-76-149	76 mm O.D., 149 mm length
S-130-39	130 mm O.D., 39 mm length
S-130-60	130 mm O.D., 60 mm length
S-130-102	130 mm O.D., 102 mm length
S-180-44	180 mm O.D., 44 mm length
S-180-69	180 mm O.D., 69 mm length
S-180-94	180 mm O.D., 94 mm length
S-240-43	240 mm O.D., 43 mm length
S-240-63	240 mm O.D., 63 mm length
S-240-83	240 mm O.D., 83 mm length
Winding Designation	
-A	Standard
NOTE: Alternate winding options are available. Contact Aerotech for more information.	

## 1.1. Motor Specifications

Table 1-2: S-50 Motor Specifications

		S-50-39		S-50-52		S-50-86	
<b>Performance Specifications</b>							
Winding Designation		-A	-B	-A	-B	-A	-B
Stall Torque, Cont.	N·m	0.21		0.32		0.59	
Peak Torque	N·m	0.8		1.3		2.4	
Rated Speed	rpm	4,000	8,000	4,000	8,000	3,000	8,000
Rated Power	W	87.5	174.6	133.6	266.4	185.0	491.2
<b>Electrical Specifications</b>							
Winding Designation		-A	-B	-A	-B	-A	-B
BEMF Const., line-line	V/krpm	10.5	3.5	16.8	5.6	34.0	11.3
Continuous Current, Stall	A	2.4	7.2	2.3	6.9	2.1	6.3
Peak Current, Stall	A	9.6	28.8	9.2	27.6	8.4	25.2
Torque Constant	N·m/A	0.087	0.029	0.139	0.046	0.281	0.094
Motor Constant	N·m/√W	0.034		0.047		0.077	
Resistance, 25 °C, line-line	Ω	6.87	0.76	8.85	0.98	13.60	1.51
Inductance, line-line	mH	1.43	0.16	1.98	0.22	3.40	0.38
Thermal Resistance	°C/W	1.94		1.64		1.28	
Maximum DC Bus Voltage	V	340		340		340	
Number of Poles	--	8		8		8	
Maximum Coil Temperature	°C	100		100		100	
<b>Mechanical Specifications</b>							
Motor Weight	kg	0.32		.048		0.90	
Motor Length	mm	39.10		51.80		85.80	
Stator OD	mm	50.80		50.80		50.80	
Rotor ID	mm	9.50		9.50		9.50	
Rotor Moment of Inertia	kg·m <sup>2</sup>	0.0000111		0.0000170		0.0000340	
<p>(1) Performance is dependent upon heat sink configuration, system cooling conditions, and ambient temperature.</p> <p>(2) Values shown at maximum coil temperature, with housed motor mounted to a 250x250x6 mm aluminum heat sink.</p> <p>(3) Peak torque assumes correct rms current; consult Aerotech.</p> <p>(4) Torque constant and motor constant specified at stall.</p> <p>(5) All performance and electrical specifications have a tolerance of ±10%.</p> <p>(6) Ambient operating temperature range 0 °C - 25 °C; consult Aerotech for performance in elevated ambient temperatures.</p> <p>(7) All Aerotech motors and amplifiers are rated using vector amplitude values. For sinusoidal signals, use sine wave peak value.</p>							

Figure 1-1: Torque Speed Curves (S-50-XX)

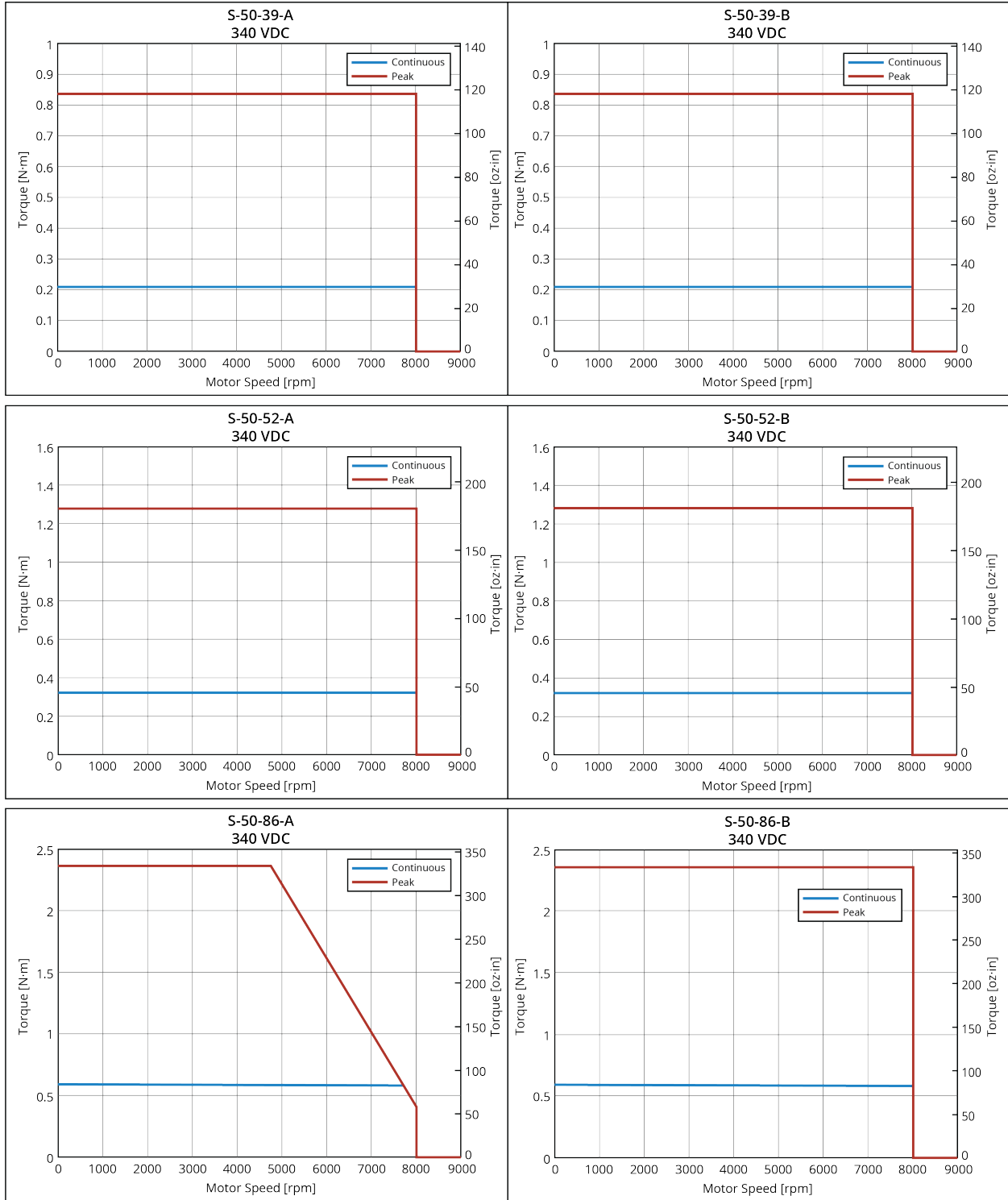

Table 1-3: S-76 Motor Specifications

		S-76-35		S-76-85		S-76-149	
<b>Performance Specifications</b>							
Winding Designation		-A	-B	-A	-B	-A	-B
Stall Torque, Cont.	N·m	0.48		1.84		3.10	
Peak Torque	N·m	1.9		7.3		12.4	
Rated Speed	rpm	3,000	5,000	3,000	4,000	2,000	1,500
Rated Power	W	151.6	252.1	573.6	763.3	645.1	484.4
<b>Electrical Specifications</b>							
Winding Designation		-A	-B	-A	-B	-A	-B
BEMF Const., line-line	V/krpm	29.3	14.6	58.4	38.9	76.4	114.6
Continuous Current, Stall	A	2.0	4.0	3.8	5.7	4.9	3.3
Peak Current, Stall	A	8.0	16.0	15.2	22.8	19.6	13.1
Torque Constant	N·m/A	0.242	0.121	0.483	0.322	0.632	0.948
Motor Constant	N·m/√W	0.075		0.199		0.296	
Resistance, 25 °C, line-line	Ω	10.71	2.68	6.04	2.68	4.66	10.49
Inductance, line-line	mH	1.97	0.49	1.32	0.59	1.06	2.39
Thermal Resistance	°C/W	1.80		0.88		0.69	
Maximum Bus Voltage	VDC	340		340		340	
Number of Poles	--	14		14		14	
Maximum Coil Temperature	°C	100		100		100	
<b>Mechanical Specifications</b>							
Motor Weight	kg	0.64		2.20		4.30	
Motor Length	mm	35.00		84.80		149.00	
Stator OD	mm	76.00		76.00		76.00	
Rotor ID	mm	30.00		30.00		30.00	
Rotor Moment of Inertia	kg·m <sup>2</sup>	0.0001060		0.0004200		0.0008300	
<p>(1) Performance is dependent upon heat sink configuration, system cooling conditions, and ambient temperature.</p> <p>(2) Values shown at maximum coil temperature, with housed motor mounted to a 250×250×6 mm aluminum heat sink.</p> <p>(3) Peak torque assumes correct rms current; consult Aerotech.</p> <p>(4) Torque constant and motor constant specified at stall.</p> <p>(5) All performance and electrical specifications have a tolerance of ±10%.</p> <p>(6) Ambient operating temperature range 0 °C - 25 °C; consult Aerotech for performance in elevated ambient temperatures.</p> <p>(7) All Aerotech motors and amplifiers are rated using vector amplitude values. For sinusoidal signals, use sine wave peak value.</p>							

Figure 1-2: Torque Speed Curves (S-76-XX)

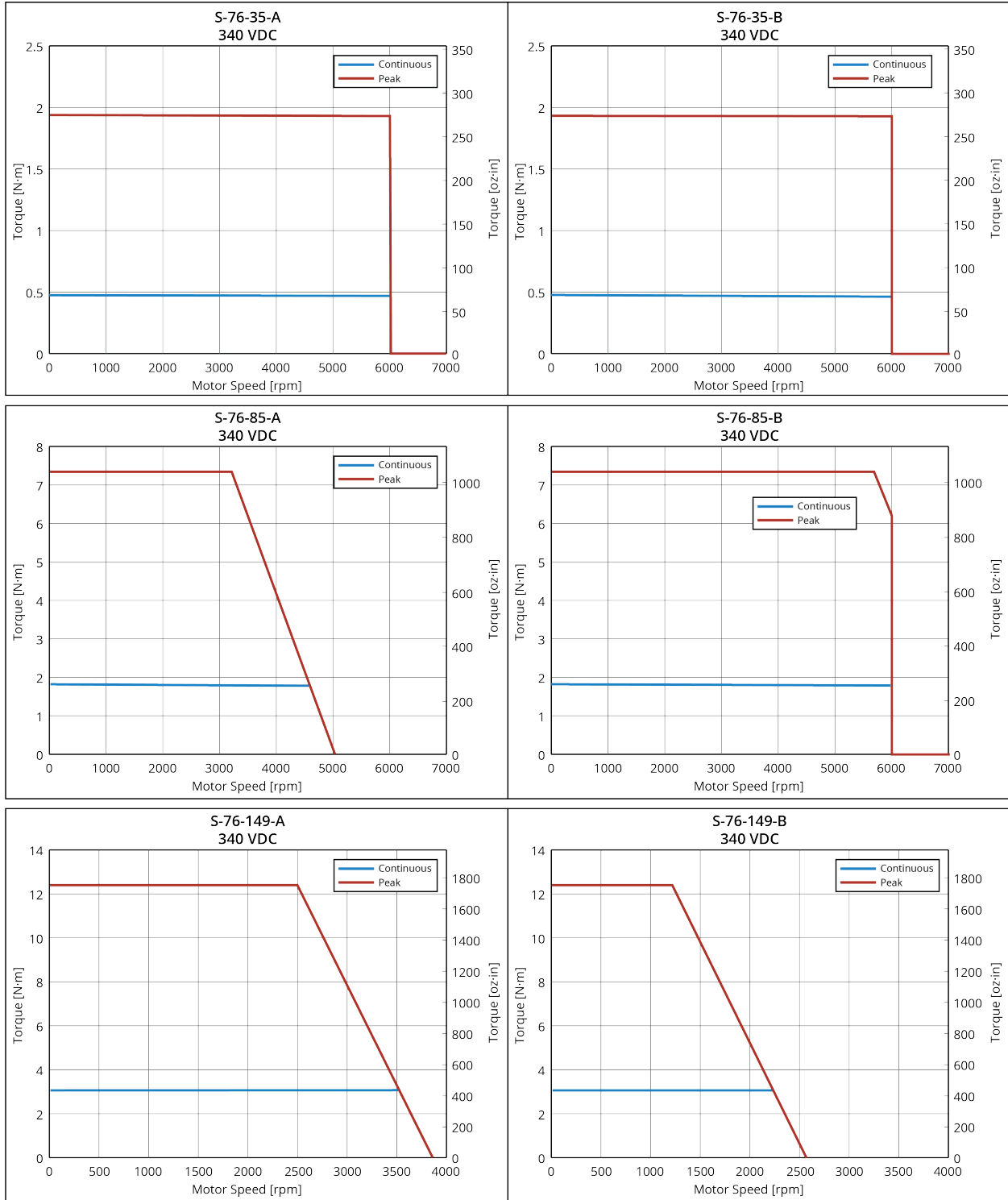

Table 1-4: S-130 Motor Specifications

		S-130-39		S-130-60		S-130-102	
<b>Performance Specifications</b>							
Winding Designation		-A	-B	-A	-B	-A	-B
Stall Torque, Cont.	N·m	2.81		5.20		9.67	
Peak Torque	N·m	11.2		20.8		38.7	
Rated Speed	rpm	2,000	4,000	1,000	2,000	500	1,000
Rated Power	W	582.9	1,152.3	540.9	1,074.4	503.9	1,003.0
<b>Electrical Specifications</b>							
Winding Designation		-A	-B	-A	-B	-A	-B
BEMF Const., line-line	V/krpm	89.3	44.6	184.9	92.4	377.0	188.5
Continuous Current, Stall	A	3.8	7.6	3.4	6.8	3.1	6.2
Peak Current, Stall	A	15.2	30.4	13.6	27.2	12.4	24.8
Torque Constant	N·m/A	0.738	0.369	1.529	0.764	3.118	1.559
Motor Constant	N·m/√W	0.299		0.527		0.866	
Resistance, 25 °C, line-line	Ω	6.26	1.57	8.64	2.16	13.29	3.32
Inductance, line-line	mH	1.61	0.40	2.63	0.66	4.59	1.15
Thermal Resistance	°C/W	0.85		0.77		0.60	
Maximum Bus Voltage	VDC	340		340		340	
Number of Poles	--	18		18		18	
Maximum Coil Temperature	°C	100		100		100	
<b>Mechanical Specifications</b>							
Motor Weight	kg	1.87		3.60		7.00	
Motor Length	mm	38.70		59.70		101.70	
Stator OD	mm	128.90		128.90		128.90	
Rotor ID	mm	50.80		50.80		50.80	
Rotor Moment of Inertia	kg·m <sup>2</sup>	0.0016000		0.0030000		0.0062000	
<p>(1) Performance is dependent upon heat sink configuration, system cooling conditions, and ambient temperature.</p> <p>(2) Values shown at maximum coil temperature, with housed motor mounted to a 250×250×6 mm aluminum heat sink.</p> <p>(3) Peak torque assumes correct rms current; consult Aerotech.</p> <p>(4) Torque constant and motor constant specified at stall.</p> <p>(5) All performance and electrical specifications have a tolerance of ±10%.</p> <p>(6) Ambient operating temperature range 0 °C - 25 °C; consult Aerotech for performance in elevated ambient temperatures.</p> <p>(7) All Aerotech motors and amplifiers are rated using vector amplitude values. For sinusoidal signals, use sine wave peak value.</p>							

Figure 1-3: Torque Speed Curves (S-130-XX)

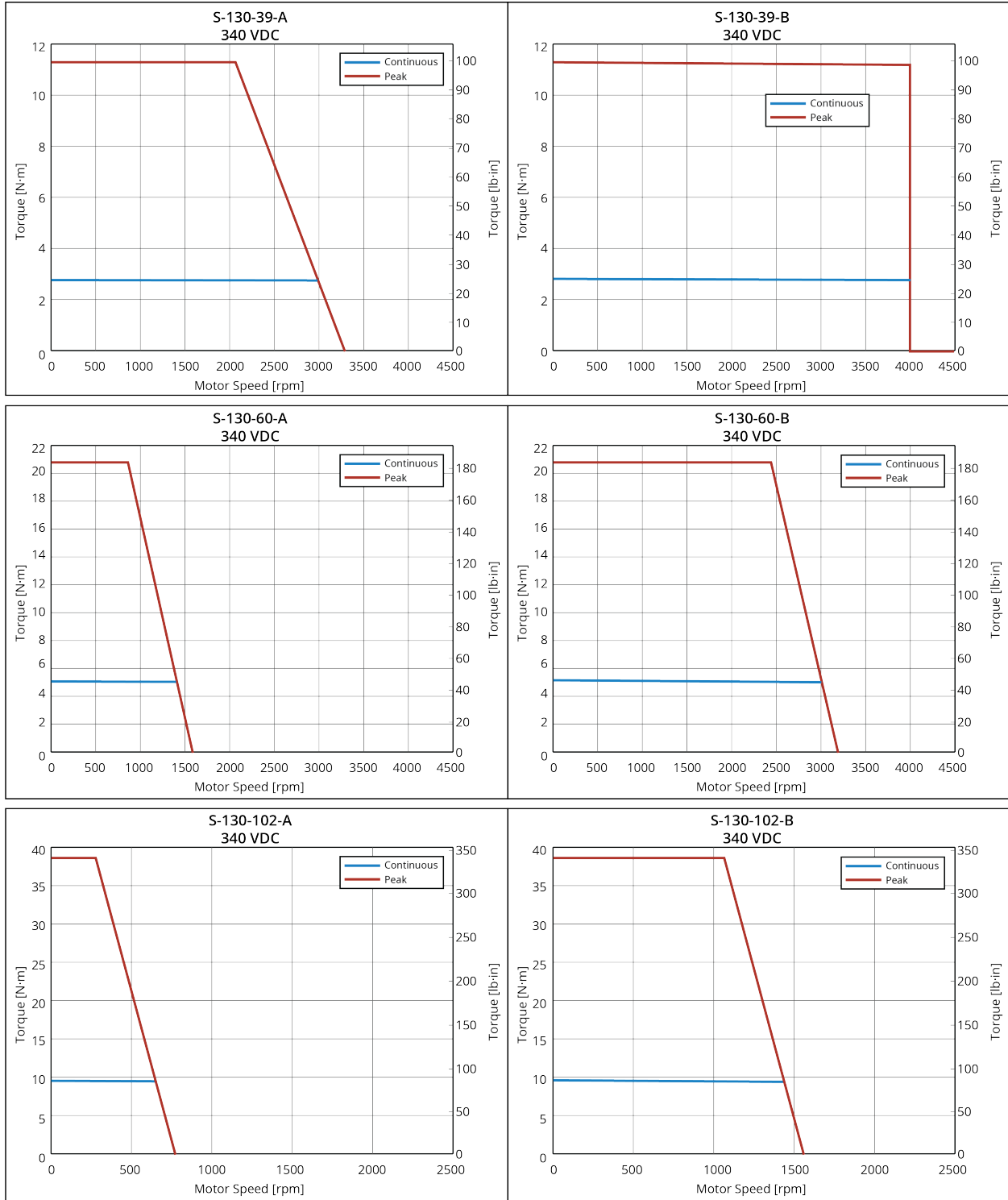

Table 1-5: S-180 Motor Specifications

		S-180-44		S-180-69		S-180-94	
<b>Performance Specifications</b>							
Winding Designation		-A	-B	-A	-B	-A	-B
Stall Torque, Cont.	N·m	6.07		11.82		17.18	
Peak Torque	N·m	24.3		47.3		68.7	
Rated Speed	rpm	500	1,000	500	1,000	250	500
Rated Power	W	316.1	628.5	614.1	1,217.3	447.2	891.1
<b>Electrical Specifications</b>							
Winding Designation		-A	-B	-A	-B	-A	-B
BEMF Const., line-line	V/krpm	271.9	135.9	280.2	140.1	424.0	212.0
Continuous Current, Stall	A	2.7	5.4	5.1	10.2	4.9	9.8
Peak Current, Stall	A	10.8	21.6	20.4	40.8	19.6	39.2
Torque Constant	N·m/A	2.249	1.124	2.318	1.159	3.507	1.753
Motor Constant	N·m/√W	0.628		1.082		1.465	
Resistance, 25 °C, line-line	Ω	13.14	3.29	4.71	1.18	5.88	1.47
Inductance, line-line	mH	6.04	1.51	2.42	0.61	3.25	0.81
Thermal Resistance	°C/W	0.80		0.63		0.54	
Maximum Bus Voltage	VDC	340		340		340	
Number of Poles	--	18		18		18	
Maximum Coil Temperature	°C	100		100		100	
<b>Mechanical Specifications</b>							
Motor Weight	kg	4.24		8.10		11.90	
Motor Length	mm	43.20		68.20		93.20	
Stator OD	mm	180.00		180.00		180.00	
Rotor ID	mm	86.40		86.40		86.40	
Rotor Moment of Inertia	kg·m <sup>2</sup>	0.0074000		0.0148000		0.0220000	
<p>(1) Performance is dependent upon heat sink configuration, system cooling conditions, and ambient temperature.</p> <p>(2) Values shown at maximum coil temperature, with housed motor mounted to a 250×250×6 mm aluminum heat sink.</p> <p>(3) Peak torque assumes correct rms current; consult Aerotech.</p> <p>(4) Torque constant and motor constant specified at stall.</p> <p>(5) All performance and electrical specifications have a tolerance of ±10%.</p> <p>(6) Ambient operating temperature range 0 °C - 25 °C; consult Aerotech for performance in elevated ambient temperatures.</p> <p>(7) All Aerotech motors and amplifiers are rated using vector amplitude values. For sinusoidal signals, use sine wave peak value.</p>							



Figure 1-4: Torque Speed Curves (S-180-XX)

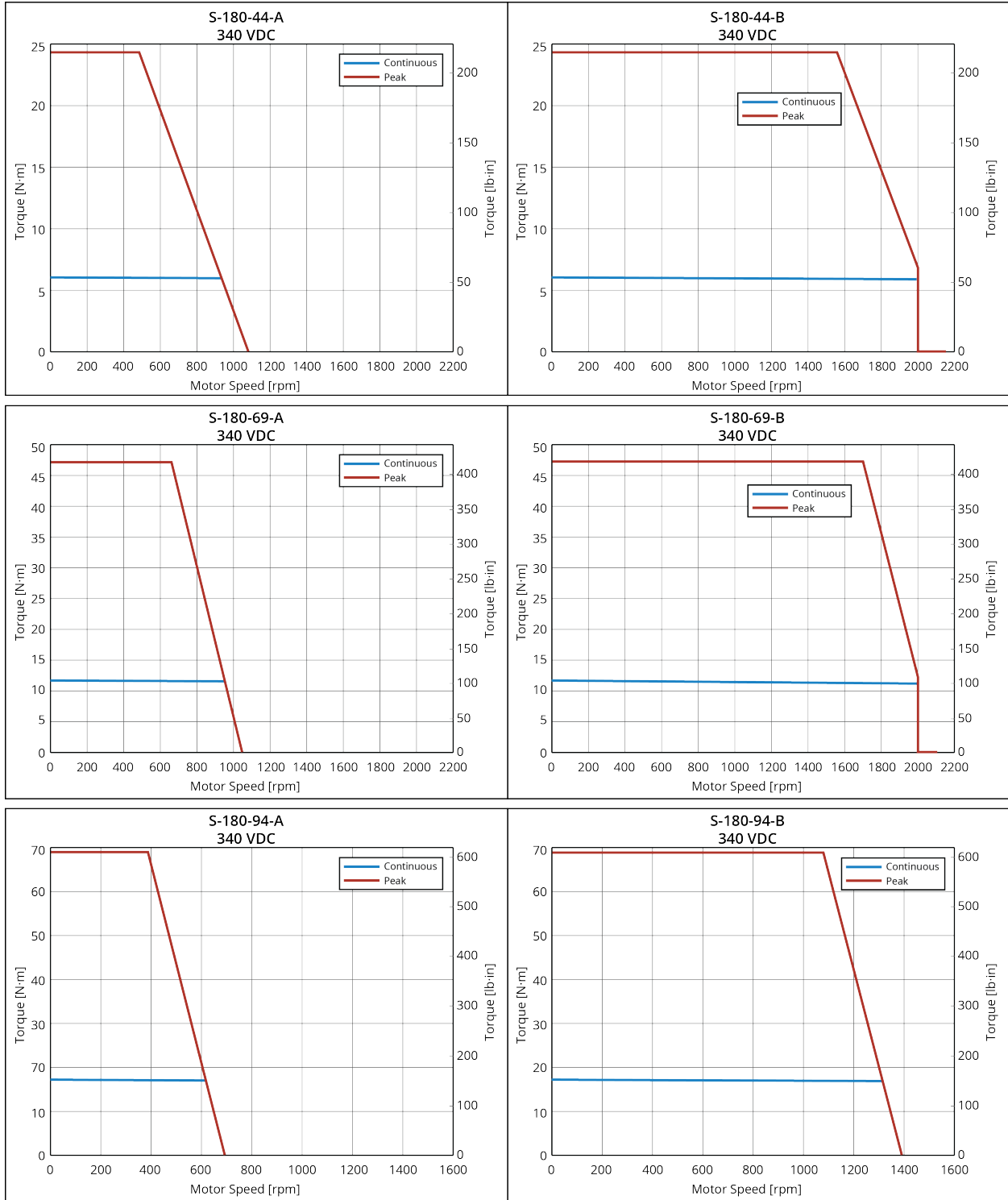
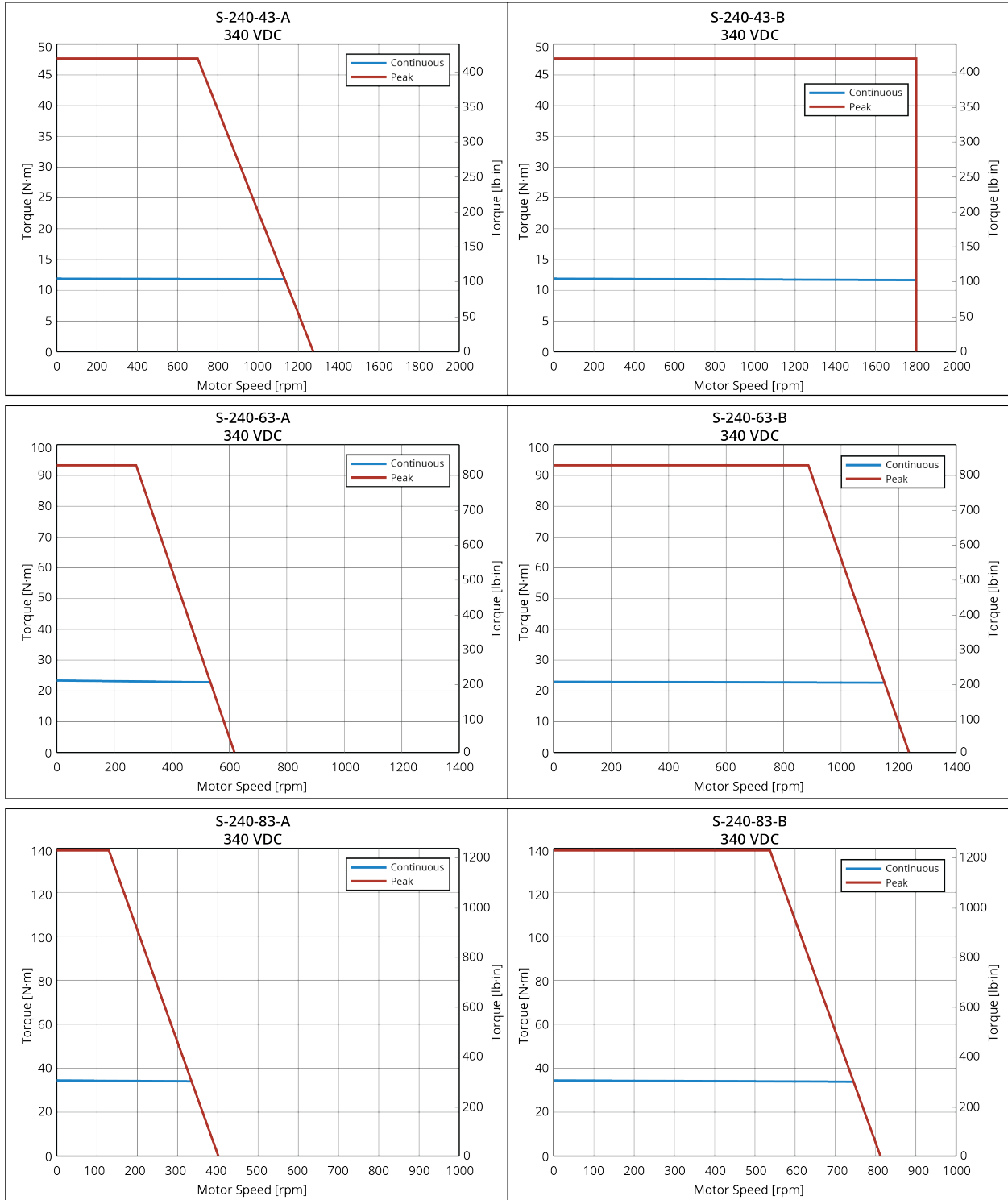

Table 1-6: S-240 Motor Specifications

		S-240-43		S-240-63		S-240-83	
<b>Performance Specifications</b>							
Winding Designation		-A	-B	-A	-B	-A	-B
Stall Torque, Cont.	N·m	11.90		23.32		34.72	
Peak Torque	N·m	47.6		93.3		138.9	
Rated Speed	rpm	600	1,200	250	500	200	400
Rated Power	W	743.6	1,478.5	608.2	1,213.2	724.6	1,445.8
<b>Electrical Specifications</b>							
Winding Designation		-A	-B	-A	-B	-A	-B
BEMF Const., line-line	V/krpm	232.0	116.0	477.8	238.9	723.8	361.9
Continuous Current, Stall	A	6.2	12.4	5.9	11.8	5.8	11.6
Peak Current, Stall	A	24.8	49.6	23.6	47.2	23.2	46.4
Torque Constant	N·m/A	1.919	0.960	3.952	1.976	5.987	2.993
Motor Constant	N·m/√W	0.901		1.619		2.207	
Resistance, 25 °C, line-line	Ω	4.65	1.16	6.11	1.53	7.55	1.89
Inductance, line-line	mH	1.98	0.50	3.06	0.77	4.11	1.03
Thermal Resistance	°C/W	0.43		0.36		0.30	
Maximum Bus Voltage	VDC	340		340		340	
Number of Poles	--	26		26		26	
Maximum Coil Temperature	°C	100		100		100	
<b>Mechanical Specifications</b>							
Motor Weight	kg	5.80		11.00		16.20	
Motor Length	mm	42.70		62.70		82.70	
Stator OD	mm	239.20		239.20		239.20	
Rotor ID	mm	120.60		120.60		120.60	
Rotor Moment of Inertia	kg·m <sup>2</sup>	0.0230000		0.0450000		0.0700000	
<p>(1) Performance is dependent upon heat sink configuration, system cooling conditions, and ambient temperature.</p> <p>(2) Values shown at maximum coil temperature, with housed motor mounted to a 250×250×6 mm aluminum heat sink.</p> <p>(3) Peak torque assumes correct rms current; consult Aerotech.</p> <p>(4) Torque constant and motor constant specified at stall.</p> <p>(5) All performance and electrical specifications have a tolerance of ±10%.</p> <p>(6) Ambient operating temperature range 0 °C - 25 °C; consult Aerotech for performance in elevated ambient temperatures.</p> <p>(7) All Aerotech motors and amplifiers are rated using vector amplitude values. For sinusoidal signals, use sine wave peak value.</p>							

Figure 1-5: Torque Speed Curves (S-240-XX)



## 1.2. Dimensions

Figure 1-6: S-50 Dimensions

Dimensions - millimeters [inches]

Model No.	A	B	C
S-50-39	21.3 [0.84]	22.0 [0.87]	39.1 [1.54]
S-50-52	34.0 [1.34]	34.8 [1.37]	51.8 [2.04]
S-50-86	67.0 [2.64]	68.8 [2.71]	84.8 [3.34]

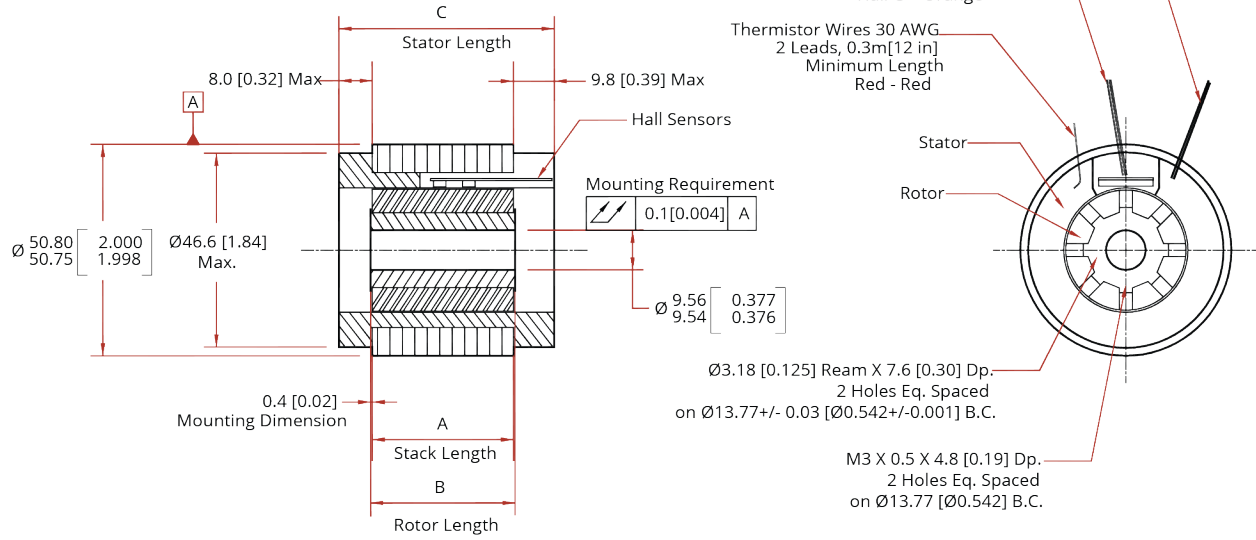

Figure 1-7: S-76 Dimensions

Dimensions - millimeters [inches]

Model No.	A	B	C
S-76-35	17.2[0.68]	18.8[0.74]	35.0[1.38]
S-76-85	67.0[2.64]	68.6[2.70]	84.8[3.34]
S-76-149	131.0[5.16]	135.0[5.31]	148.8[5.86]

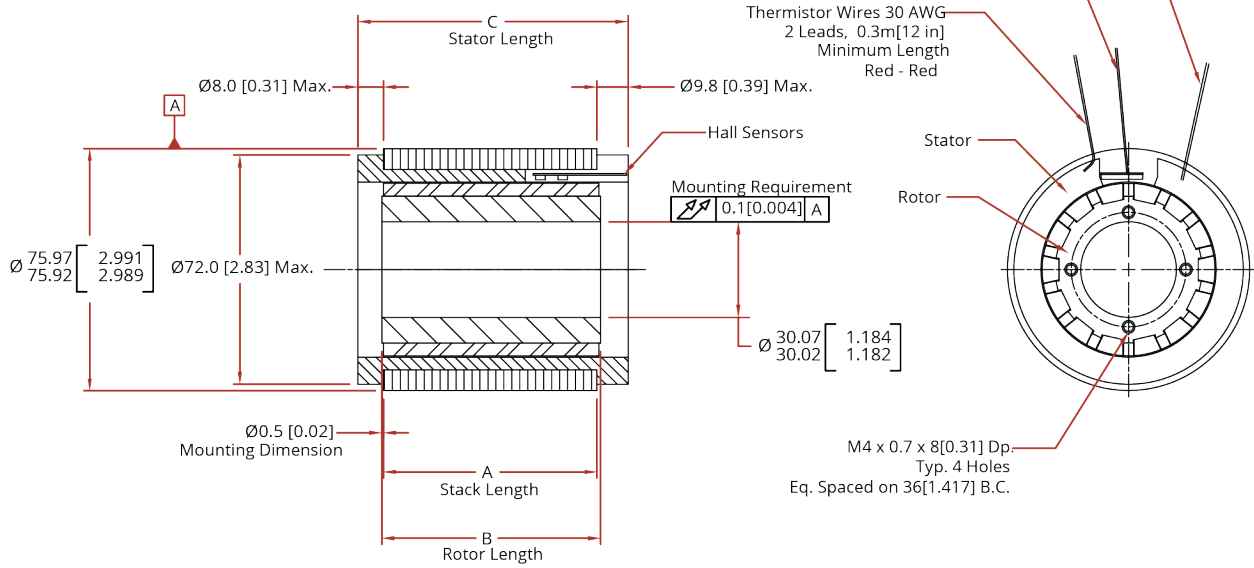
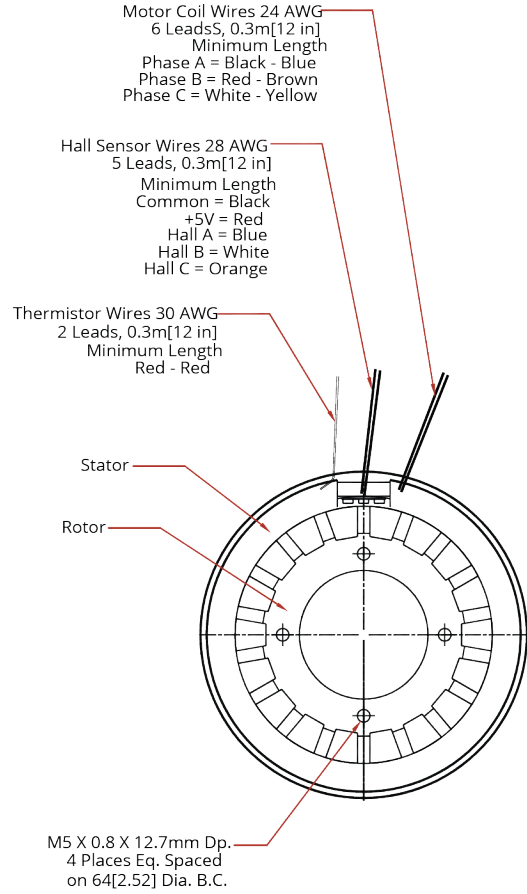
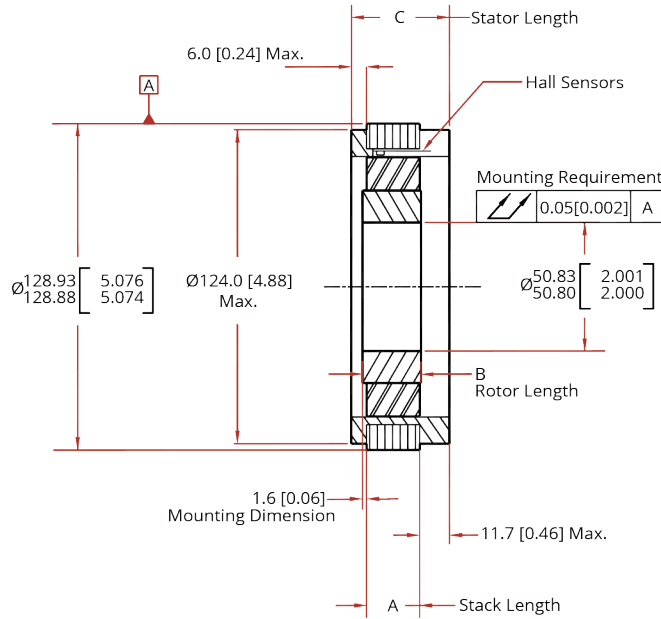

Figure 1-8: S-130 Dimensions

Dimensions - millimeters [inches]

Model No.	A	B	C
S-130-39	21.0 [0.82]	23.1 [0.91]	38.7 [1.52]
S-130-60	42.0 [1.65]	44.1 [1.74]	59.7 [2.35]
S-130-102	84.0 [3.30]	86.1 [3.39]	101.7 [4.00]



**Figure 1-9: S-180 Dimensions**

Dimensions - millimeters [inches]

Model No.	A	B	C
S-180-44	25.0 [0.98]	26.0 [1.02]	43.2 [1.70]
S-180-69	50.0 [1.97]	51.0 [2.01]	68.2 [2.69]
S-180-94	75.0 [2.95]	76.0 [2.99]	93.2 [3.67]

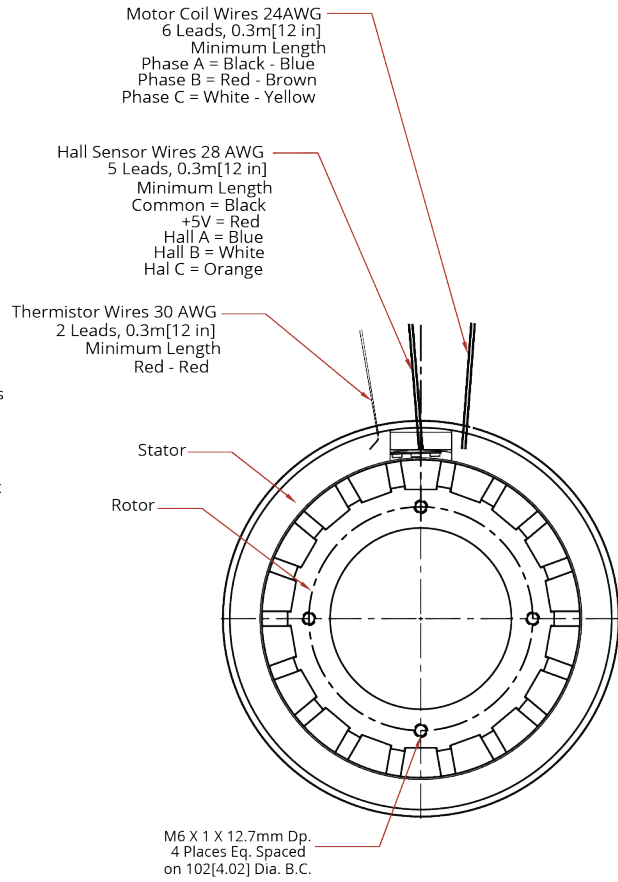
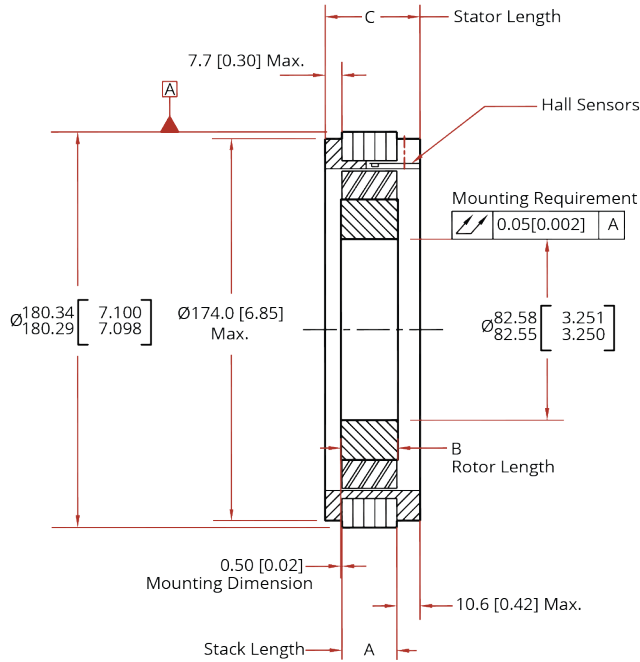

**Figure 1-10: S-240 Dimensions**

Dimensions - millimeters [inches]

Model No.	A	B	C
S-240-43	21.0 [0.827]	22.0 [0.866]	40.7 [1.602]
S-240-63	42.0 [1.653]	43.0 [1.693]	61.7 [2.429]
S-240-83	63.0 [2.480]	64.0 [2.520]	82.7 [3.256]

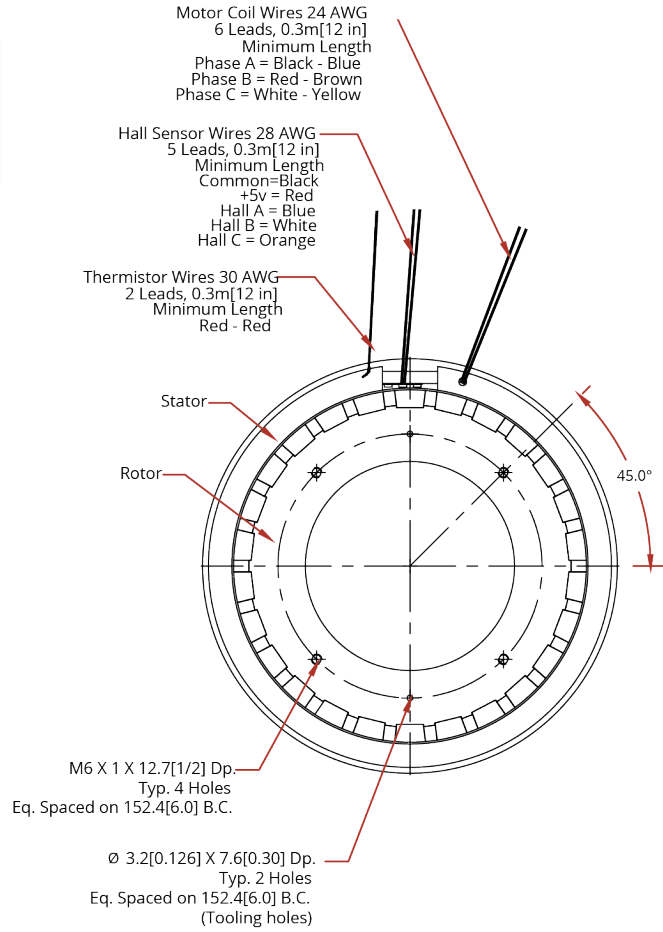
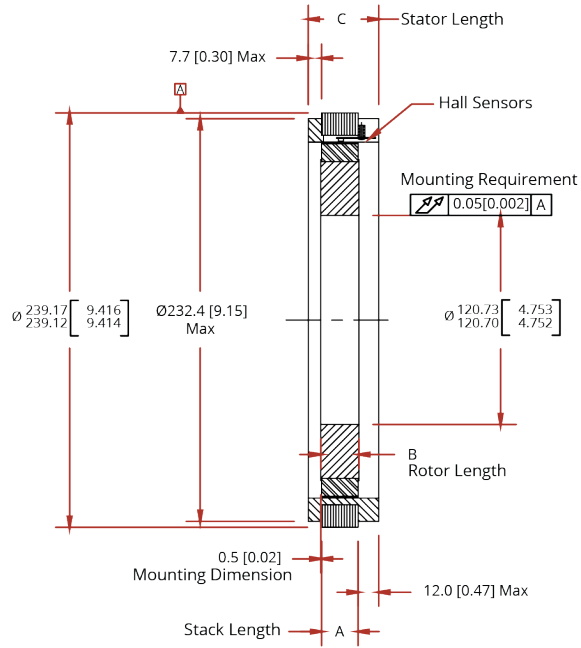



### 1.3. Environmental Specifications



**WARNING:** Use this product only in environments and operating conditions that are approved in this manual.

**Table 1-7: Environmental Specifications**

<b>Ambient Temperature</b>	Operating: 0 °C to 25 °C (32 °F to 77 °F) Contact Aerotech for information regarding your specific application and environment.
	Storage: -10 °C to 85 °C (14 °F to 185 °F) in original shipping packaging
<b>Humidity</b>	Operating: 20% to 60% RH
	Storage: 10% to 70% RH, non-condensing in original packaging.
	Ambient conditions need to be such that condensation on the motor does not occur. The motors are not to be used in wash-down environments.
<b>Altitude</b>	Operating: 0 m to 1,000 m (0 ft to 3,280 ft) above sea level
	Contact Aerotech if your specific application involves use above 1,000 m or below sea level.
<b>Atmosphere</b>	Not to be used in a hydrogen atmosphere.
<b>Use</b>	Indoor use only

### 1.4. Vacuum Operation

Standard S-Series motors are not considered to be vacuum-compatible. Aerotech can specially prepare S-Series motors for operation in vacuum environments up to and including ultra-high-vacuum (UHV). Vacuum-rated versions are typically de-rated by 40-60% of the continuous current limit. Additionally, maximum operating speeds will also be limited. Contact Aerotech for more information.

*This page intentionally left blank.*

## Chapter 2: Assembly and Installation



**WARNING:** To prevent injury or damage to the equipment, you will need devices in place that will prevent unexpected motion in the event of an intentional or unintentional disruption of electrical power. Applications with vertical axes require a fail-safe brake.

Aerotech, Inc. supplies the parts that follow:

1. Stator Assembly
2. Rotor Assembly

The customer must supply the parts that follow:

1. Stator Housing
2. Stator Clamp Ring
3. Shaft Assembly
4. Rotor Clamp Ring
5. Mounting Hardware
6. Mylar Shim Stock

### 2.1. Stator Housing Requirements

The housing needs to be a structurally strong rigid body that will not deform when mounting the stator in place. The housing bore diameter needs to be 0.001 inches to 0.002 inches larger than the stator outside diameter. The bore depth must be less than the height of the lamination stack so the laminations of the stator can be clamped without bottoming out the clamp (refer to [Figure 2-1](#)). The housing should also include a shoulder perpendicular to the bore for locating the motor. The ID of this shoulder must provide clearance for the motor coils.

The stator must be clamped in the axial direction with a stator clamp ring. The clamp must have adequate surface area to retain the motor lamination stack. The ID of the ring must also allow for clearance of the motor coils. Multiple screws (4 or more) should be used to bolt the clamp ring to the housing. For added strength the stator can be bonded in place and/or radial setscrews can be used in addition to the stator clamp ring.

## 2.2. Rotor Shaft Requirements

The rotor shaft diameter should be no more than 0.003 inches smaller than the rotor hub ID. The shaft should also have a shoulder perpendicular to the OD of the shaft for locating the rotor.

The rotor can be clamped in the axial direction with a bolted clamp ring (Figure 2-1). The clamp ring OD must not interfere with the stator ID. Use four or more screws to bolt the clamp ring to the shaft.

As shown in Figure 2-2, the rotor can also be bolted to the shaft via the tapped holes in the rotor hub. When the rotor is bolted to the shaft, use thread locker on the attachment screws.

For added strength, you can bond the rotor onto the shaft. You can also use a keyway in addition to mechanically attaching the rotor to the shaft.

**Figure 2-1: Motor Mounting Using Stator and Rotor Clamp Rings**

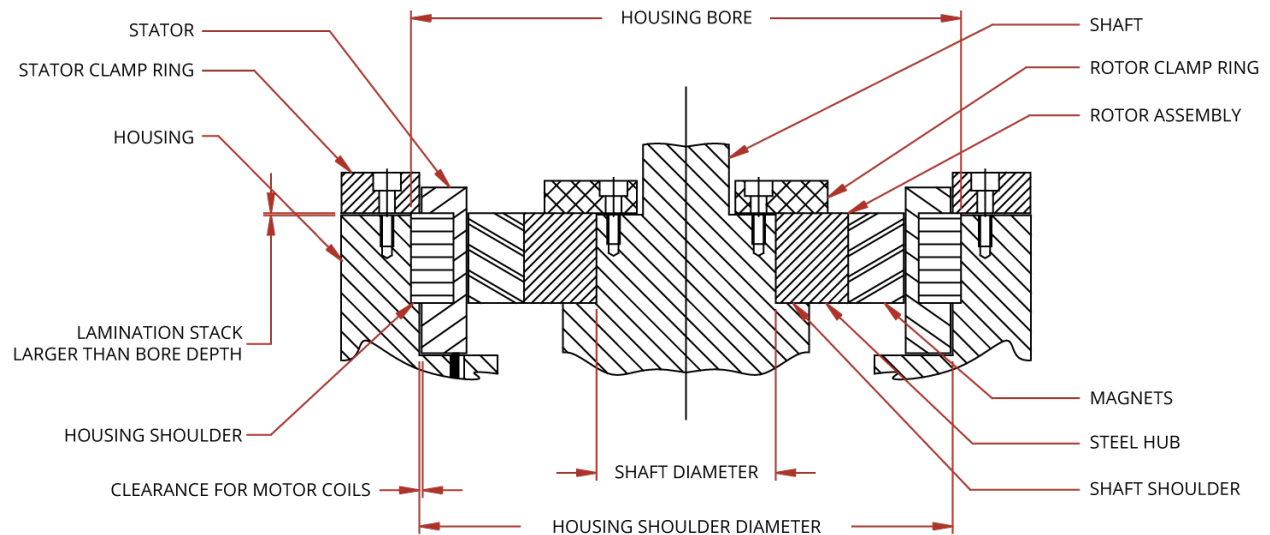

**Figure 2-2: Motor Mounting Using Direct Bolting of the Rotor to the Shaft**

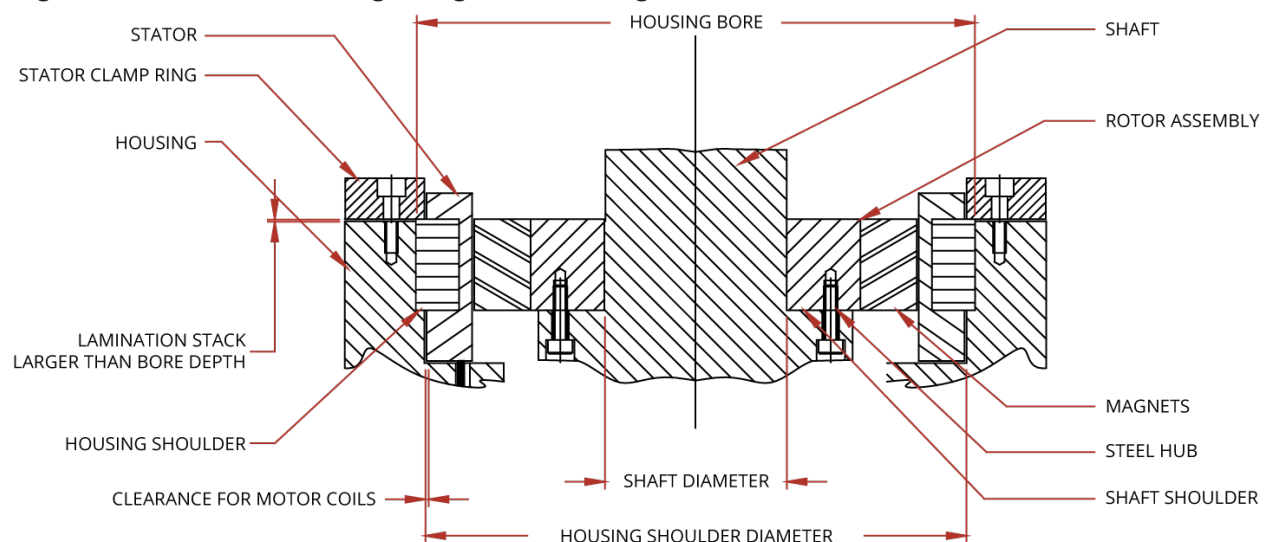

## 2.3. Motor Assembly



**DANGER: Strong Magnets / Electromagnetic Fields:** The rotor could unexpectedly attract and clamp to a magnetic surface and cause injury or damage to the equipment.

- Interaction with metallic objects could produce pinch dangers.
- Use non-magnetic tools when you do service to the motor.
- Keep the rotor away from magnetic materials while you handle and install it.

Because of system variations, the list that follows is only a general check-off style guide to the motor assembly. Specific details of your particular installation also apply.



**IMPORTANT:** Before you assemble the motor, verify that the Hall sensor card is in the correct position for the desired commutation offset. You will have to disassemble the motor if you need to move the card.

- The standard Aerotech Hall sensor commutation offset is 0°.
- A 30° offset requires moving the card.
- Refer to the Hall Card Placement section ([Section 2.4.](#)) to change the offset.

1. Insert the stator into the stator housing.
2. Clamp the stator in the housing with the stator clamp ring.
3. Cut mylar shim stock to be placed around the inside diameter of the stator.
  - Make the shims are long enough to allow for their removal after the rotor is installed.
  - Shim thickness needs to be less than the air gap between the rotor and stator.
  - Place the shims so the rotor OD will not contact the stator ID during motor assembly.
4. Insert screws, all thread, or custom tooling in the threaded holes on the rotor face. The hardware or tooling will be used to lower the rotor into the stator.



**DANGER: Magnetic Forces Hazard!** The step that follows will expose you to a magnetic hazard. When you insert the rotor in to the stator, the rotor will be pulled axially into the stator. The force of the magnetic pull could be very quick and unexpected.

5. Be extremely careful when you lower the rotor onto the shaft and into the stator. An ideal shaft and housing design will restrain the rotor from radial movement so as not to be magnetically attracted to the stator during insertion.
6. Clamp the rotor to the shaft with the rotor clamp ring.
7. Remove the shims.
8. Verify the rotor does not contact the stator during rotation.
9. Verify the air gap between the rotor and stator for a full 360° of rotation.

## 2.4. Hall Card Placement

Aerotech motors are supplied with a 0° offset between the Hall signals and corresponding line-to-neutral BEMF voltages. This can be changed to a 30° offset by removing the mounting screws and remounting the card in the position shown in Figure 2-3. Moving the card requires disassembly of the motor.

Figure 2-4 shows the motor BEMF to Hall signal relationships for both 0° and 30° commutation offsets for a counterclockwise (CCW) rotation. Note that with 30° offset, the Hall signals align with the line-to-line BEMF voltages. The correct CCW rotation is with the motor viewed from the cable-side exit, which corresponds to the positive motor rotation.

**Figure 2-3: Hall Board Placement**

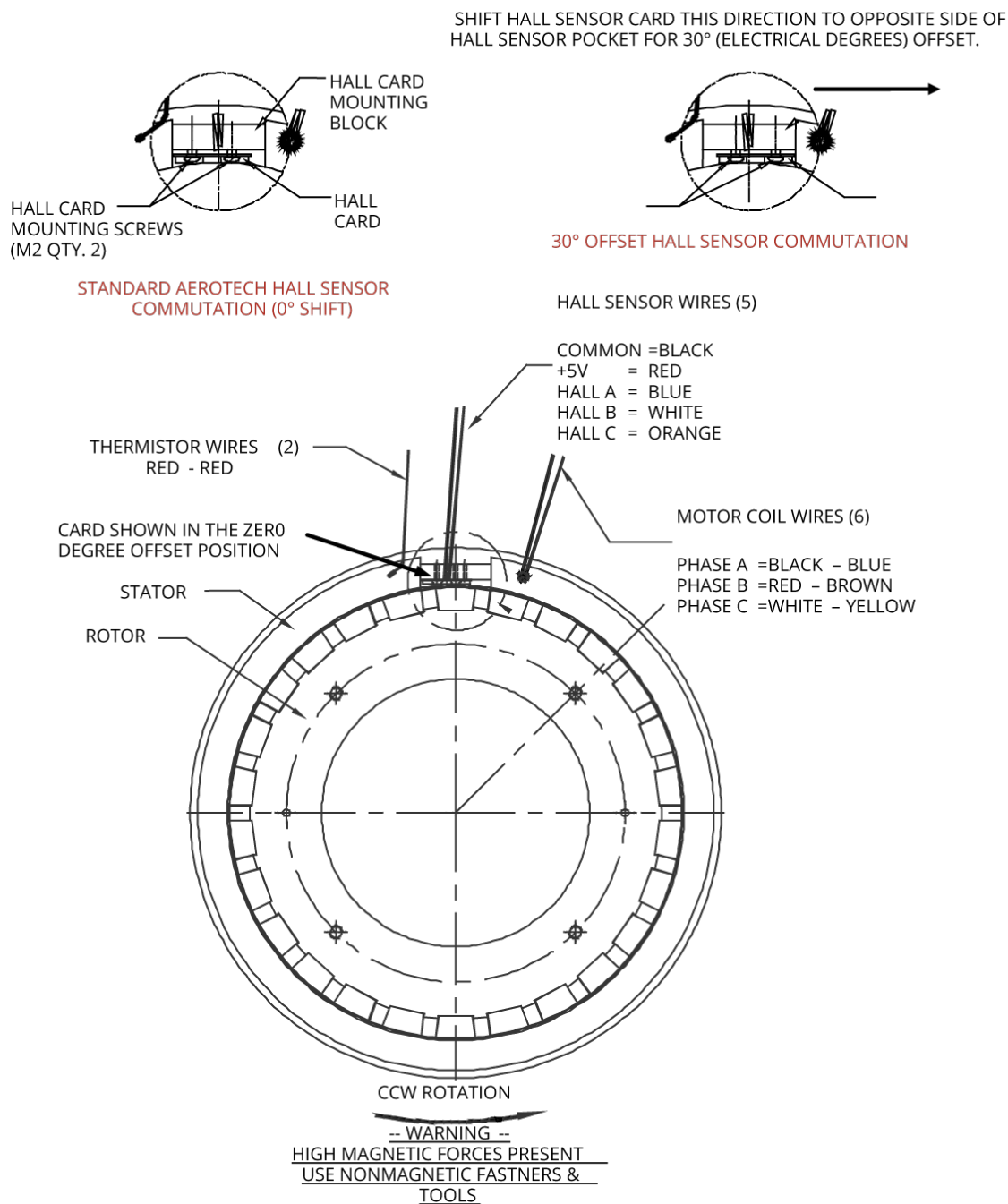
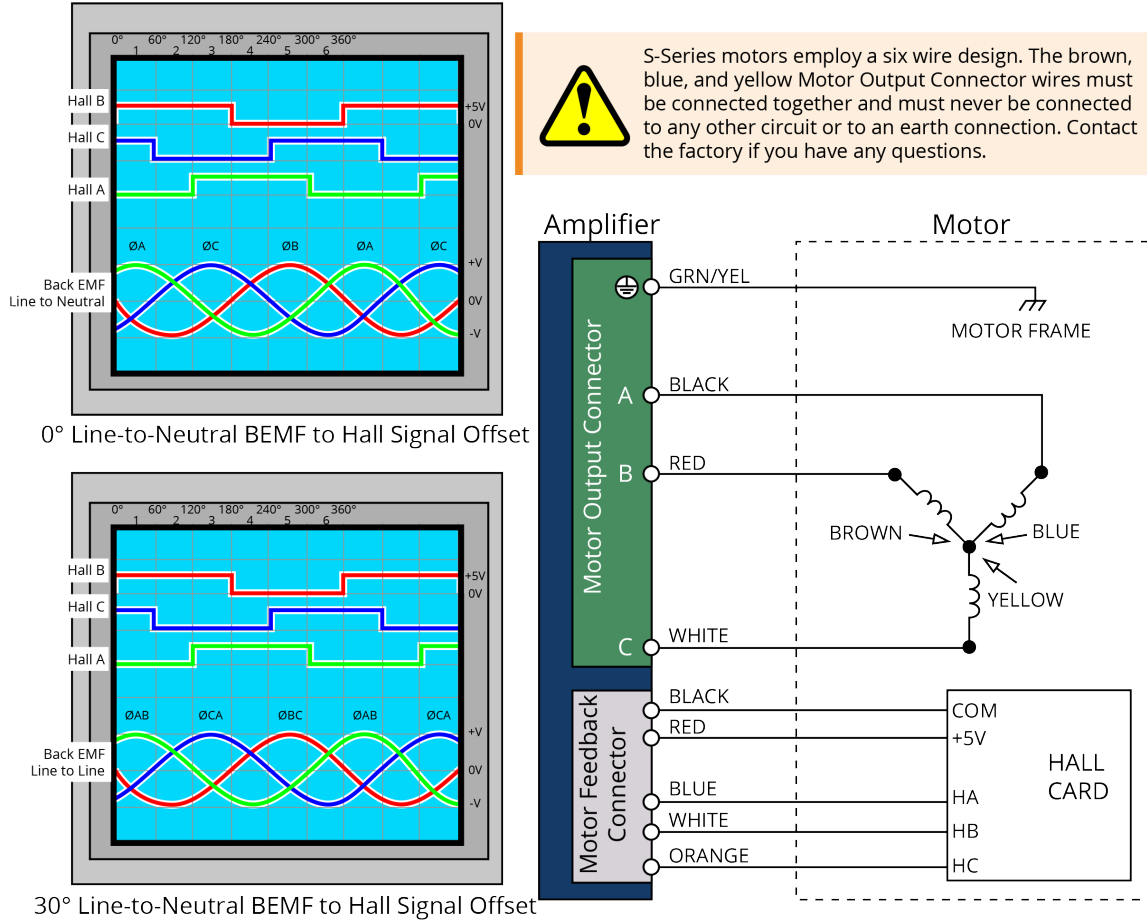

Figure 2-4: Motor BEMF and Hall Signal Relationship



NOTES:

1. Hall-signal measurements are made with reference to signal common.
2. For counterclockwise rotation, the motor is viewed from the cable-side exit
3. Listed wire colors are for Aerotech-supplied cables.

## 2.5. External Motor Wiring

The stator is supplied with flying leads for the motor winding, Hall effect devices, and thermal overload sensor. It is the responsibility of the customer to supply all external wiring to interface with these devices. Customer-supplied wiring must obey all local electrical safety requirements.

- The wiring must be able to supply the rated current without overheating.
- The wire insulation must be rated for the voltage and temperature at which the motor is operating.
- Cable selection and installation should be made to reduce EMI emissions and to increase EMI immunity.

In addition to the external wiring, it is also the responsibility of the customer to provide over-current protection for the motor.

**Table 2-1: Connector Wire Gauge**

Motor Leads	Feedback Leads	Thermistor Leads
24 AWG (.21 mm <sup>2</sup> )	28 AWG (.08 mm <sup>2</sup> )	30 AWG (.05 mm <sup>2</sup> )

### 2.5.1. Motor Power Conductors

The motor power conductors must be sized to handle the electrical current requirements of the motor (refer to [Section 1.1. Motor Specifications](#)). Select the wire insulation voltage rating based on the maximum voltage that will be applied to the motor.



**WARNING:** S-Series motors employ a six wire design. The brown, blue, and yellow Motor Output Connector wires must be connected together and must never be connected to any other circuit or to an earth connection. Contact the factory if you have any questions.

### 2.5.2. Protective Ground

The protective ground is a safety conductor that you must use to ground the motor case. The protective ground conductor must have a current carrying capacity at least equal to the carrying capacity of the motor wires. The standard insulation is "Green/Yellow" and must be rated for the maximum voltage applied to the motor winding. The protective ground wire is typically bundled with the motor wires, but your system could require a separate protective ground wire.

### 2.5.3. Over-Current Protection

You will need to provide the motor with over-current protection to prevent the motor from overheating. Use programmable current limits, traps, over-current protection circuitry, or fuses. Fuse values should be selected according to the RMS current rating of the motor. For most applications, you should use slow-blow type fuses.

When the motor is part of an Aerotech system that uses an Aerotech controller and drive, the motor over-current protection fault must be set to whichever is lower: the peak continuous current rating of the motor or the drive continuous current rating.



### 2.5.4. Hall-Effect Device and Thermistor Wiring

The insulation of these wires should have a rating for at least the maximum voltage applied to the motor winding. The temperature rating of the wire insulation must also be sufficiently high to withstand the operating temperatures specific to the application.

### 2.5.5. Wiring Guidelines

The wiring guidelines given below can help to reduce EMI related problems which can result in poor overall system performance.

- Keep cable lengths as short as possible. Long cable runs are more susceptible to EMI pickup than short runs.
- Use shielded cables for both the motor power and signal wiring with the shield connected to a low impedance earth ground connection at each end.
- Use twisted pair shielded cabling to help reduce magnetically induced currents.
- Braided shield has a slightly better low frequency shielding capability than a foil shield. Foil is often used where RF shielding is necessary.
- Do not bundle signal, motor power cables, or AC power lines within the same protective shield or conduit. Use separate protective shields or conduits.
- Do not introduce multiple paths to ground from a grounding point. Multiple paths to ground can create ground loops within the system.
- If necessary, use an EMI suppression device.

### 2.5.6. Thermal Protective Device

S-Series motors use a positive-temperature coefficient (PTC) thermistor as a thermal protection device. The nominal resistance of the thermistor is 100 ohms at 25 °C. The resistance of the thermistor will increase rapidly to 1,000 ohms as the motor temperature increases to the 100 °C transition temperature of the thermistor.



**WARNING:** The thermal protective device used in the motor must be connected to an external shutdown circuit to provide protection to the motor.

Figure 2-5: Thermal Sensor Resistance as a Function of Temperature

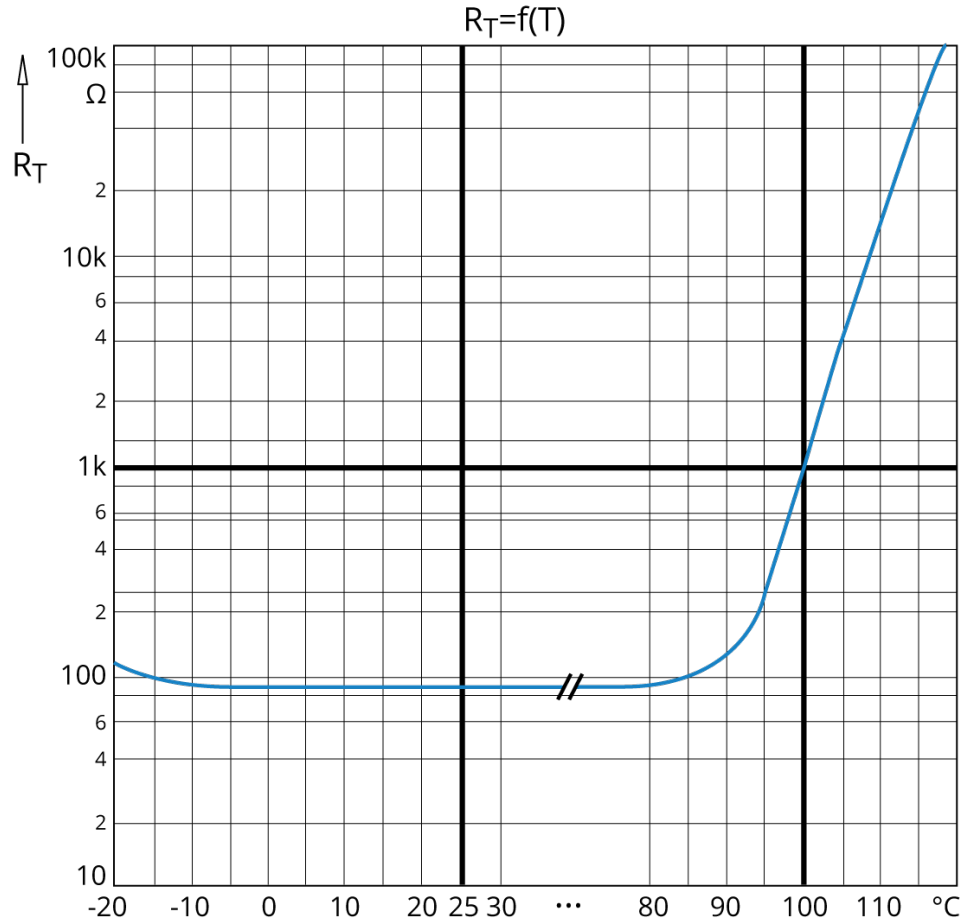



**WARNING:** If you connect the thermistor to the interface circuit incorrectly, you could cause the thermistor to self-heat. If too much current passes through the thermistor, the temperature will increase and cause the thermistor to activate and increase resistance.

**Figure 2-6: Typical Thermistor Interface Circuit**

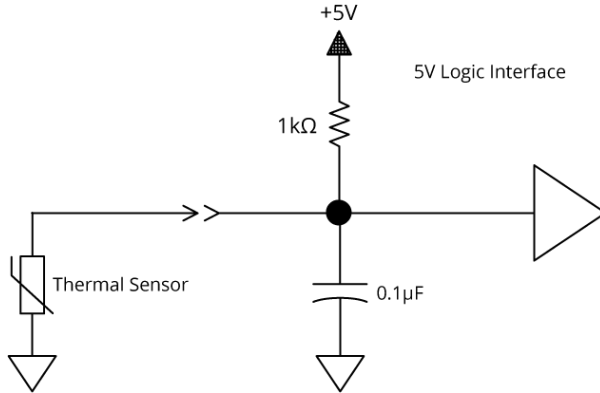

## 2.6. Motor Heating

The amount of current that can pass through the motor winding is limited by a rise in temperature above ambient. If the temperature of the motor exceeds the thermal limit, the thermistor sensor will send a signal to the controller and the controller will stop the motor.

The motor specifications show the continuous motor current that will result in a predetermined temperature rise of the motor. The motor specifications listed in [Section 1.1.](#) were compiled under a single set of operating conditions and environmental specifications ([Section 1.3.](#)).

The operating conditions of the motor are defined by:

- The thermal characteristics of the motor.
- The effectiveness of the medium that surrounds the motor to transfer heat away from the motor.
- The use of supplemental cooling.

Examples of what could cause the motor to overheat:

- Poor heat transfer away from the motor.
- The load is too high for the motor.
- The ambient temperature has increased above the expected operating conditions.

Refer to the motor torque curves ([Figure 1-1](#) to [Figure 1-5](#)) to see the safe region of operation for each motor. The example in [Figure 2-7](#) shows what the boundary for each torque curve means.

- The thermal limit of the motor will not be exceeded if the motor is operated within the region bounded by the Continuous Operating Curve.
- Motor operation in the region bounded by the Peak Operating Curve has to be limited in time or the temperature of the motor will exceed the thermal limit.

**Figure 2-7: Operating Regions Example**

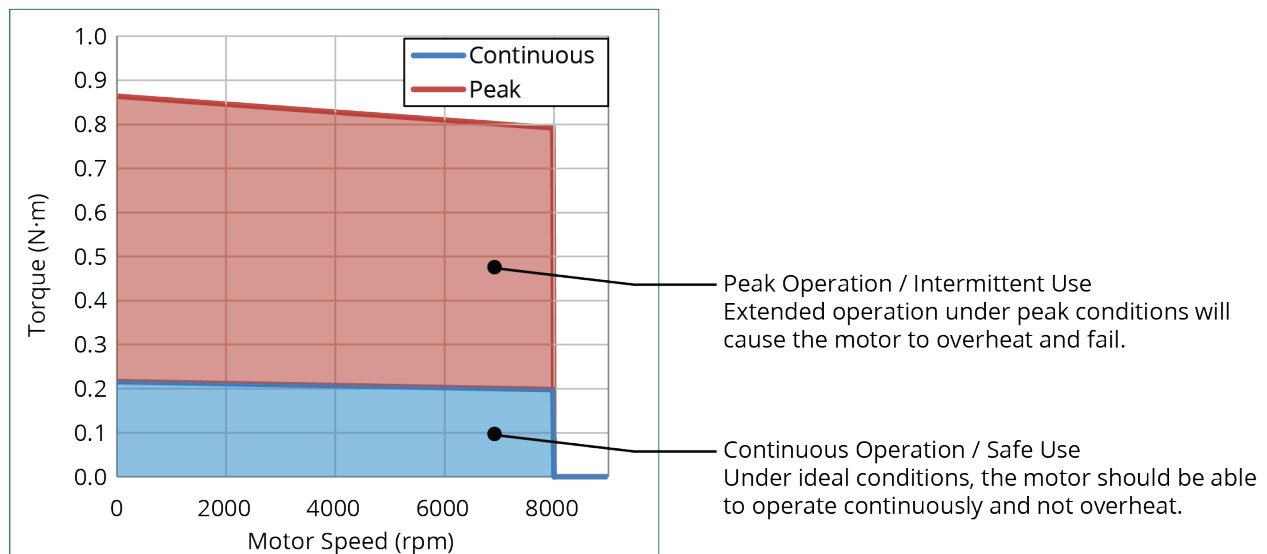

## Chapter 3: Maintenance



**DANGER:** To minimize the possibility of bodily injury or death, disconnect all electrical power before you do maintenance or make adjustments to the equipment.



**DANGER: Strong Magnets / Electromagnetic Fields**

- Interaction with metallic objects could produce pinch dangers.
- Use non-magnetic tools when you do service to the motor.

Inspect the S-Series motor at least once per month. You will have to determine a longer or shorter inspection interval based on the application and conditions, such as the duty cycle, speed, and environment.

Visually inspect the motor and cables to make sure that:

- the motor does not become too hot.
- the motor does not vibrate too much.
- you do not see evidence of burns or smell smoke.

You will also need to

- tighten loose motor-to-machine hardware.
- remove an accumulation of debris on the motor.
- replace or repair damaged cables.
- clean the motor and any components and cables if needed.
- assess any damage to the motor.

### Cleaning

Motors should be wiped with a clean dry cloth to remove any grease, dirt, or other material that has accumulated on the motor. Do not use fluids and sprays so that you do not contaminate the internal parts of the motor. Be careful when you clean the motor so that you do not remove the text on the motor labels.

### Lubrication

S-Series motors are noncontacting devices. The rotor and stator supplied by Aerotech do not require lubrication. It is the responsibility of the customer or OEM to lubricate customer-supplied components.

### Repairs

In general, it is not possible for field service personnel to repair and/or replace damaged or components that have malfunctioned. Repair typically requires that you return the unit to the factory.

Contact Aerotech Global Technical Support for more information.

*This page intentionally left blank.*

## Appendix A: Warranty and Field Service

Aerotech, Inc. warrants its products to be free from harmful defects caused by faulty materials or poor workmanship for a minimum period of one year from date of shipment from Aerotech. Aerotech's liability is limited to replacing, repairing or issuing credit, at its option, for any products that are returned by the original purchaser during the warranty period. Aerotech makes no warranty that its products are fit for the use or purpose to which they may be put by the buyer, whether or not such use or purpose has been disclosed to Aerotech in specifications or drawings previously or subsequently provided, or whether or not Aerotech's products are specifically designed and/or manufactured for buyer's use or purpose. Aerotech's liability on any claim for loss or damage arising out of the sale, resale, or use of any of its products shall in no event exceed the selling price of the unit.

THE EXPRESS WARRANTY SET FORTH HEREIN IS IN LIEU OF AND EXCLUDES ALL OTHER WARRANTIES, EXPRESSED OR IMPLIED, BY OPERATION OF LAW OR OTHERWISE. IN NO EVENT SHALL AEROTECH BE LIABLE FOR CONSEQUENTIAL OR SPECIAL DAMAGES.

### Return Products Procedure

Claims for shipment damage (evident or concealed) must be filed with the carrier by the buyer. Aerotech must be notified within thirty (30) days of shipment of incorrect material. No product may be returned, whether in warranty or out of warranty, without first obtaining approval from Aerotech. No credit will be given nor repairs made for products returned without such approval. A "Return Materials Authorization (RMA)" number must accompany any returned product(s). The RMA number may be obtained by calling an Aerotech service center or by submitting the appropriate request available on our website ([www.aerotech.com](http://www.aerotech.com)). Products must be returned, prepaid, to an Aerotech service center (no C.O.D. or Collect Freight accepted). The status of any product returned later than thirty (30) days after the issuance of a return authorization number will be subject to review.

Visit [Global Technical Support Portal](#) for the location of your nearest Aerotech Service center.

### Returned Product Warranty Determination

After Aerotech's examination, warranty or out-of-warranty status will be determined. If upon Aerotech's examination a warranted defect exists, then the product(s) will be repaired at no charge and shipped, prepaid, back to the buyer. If the buyer desires an expedited method of return, the product(s) will be shipped collect. Warranty repairs do not extend the original warranty period.

**Fixed Fee Repairs** - Products having fixed-fee pricing will require a valid purchase order or credit card particulars before any service work can begin.

**All Other Repairs** - After Aerotech's evaluation, the buyer shall be notified of the repair cost. At such time the buyer must issue a valid purchase order to cover the cost of the repair and freight, or authorize the product(s) to be shipped back as is, at the buyer's expense. Failure to obtain a purchase order number or approval within thirty (30) days of notification will result in the product(s) being returned as is, at the buyer's expense.

Repair work is warranted for ninety (90) days from date of shipment. Replacement components are warranted for one year from date of shipment.

### Rush Service

At times, the buyer may desire to expedite a repair. Regardless of warranty or out-of-warranty status, the buyer must issue a valid purchase order to cover the added rush service cost. Rush service is subject to Aerotech's approval.

### On-site Warranty Repair

If an Aerotech product cannot be made functional by telephone assistance or by sending and having the customer install replacement parts, and cannot be returned to the Aerotech service center for repair, and if Aerotech determines the problem could be warranty-related, then the following policy applies:

Aerotech will provide an on-site Field Service Representative in a reasonable amount of time, provided that the customer issues a valid purchase order to Aerotech covering all transportation and subsistence costs. For warranty field repairs, the customer will not be charged for the cost of labor and material. If service is rendered at times other than normal work periods, then special rates apply.

If during the on-site repair it is determined the problem is not warranty related, then the terms and conditions stated in the following "On-Site Non-Warranty Repair" section apply.

### On-site Non-Warranty Repair

If any Aerotech product cannot be made functional by telephone assistance or purchased replacement parts, and cannot be returned to the Aerotech service center for repair, then the following field service policy applies:

Aerotech will provide an on-site Field Service Representative in a reasonable amount of time, provided that the customer issues a valid purchase order to Aerotech covering all transportation and subsistence costs and the prevailing labor cost, including travel time, necessary to complete the repair.

### Service Locations

<https://www.aerotech.com/contact-sales.aspx?mapState=showMap>

#### USA, CANADA, MEXICO

Aerotech, Inc.  
Global Headquarters

#### CHINA

Aerotech China  
Full-Service Subsidiary

#### GERMANY

Aerotech Germany  
Full-Service Subsidiary

#### TAIWAN

Aerotech Taiwan  
Full-Service Subsidiary

#### UNITED KINGDOM

Aerotech United Kingdom  
Full-Service Subsidiary



## Appendix B: Revision History

Revision	Description
3.02	General Update
3.01	Dimension drawings updated: <a href="#">Section 1.2. Dimensions</a>
3.00	<ul style="list-style-type: none"><li>• EU Declaration of Conformity updated.</li><li>• UK Declaration of Conformity added.</li><li>• Safety Procedures and Warnings updated.</li><li>• Ordering options updated (S-130-xx)</li><li>• Specifications updated (S-130-xx)</li><li>• Dimensions updated (S-130-xx)</li></ul>
2.02	Revision changes have been archived. If you need a copy of this revision, contact AerotechGlobal Technical Support.
2.01	
2.00	
1.01	
1.00	

*This page intentionally left blank.*



Electrical Specifications	20
Mechanical Specifications	20
Performance Specifications	20
S-76 Motor Specifications	20
S-130	
Dimensions	30
Electrical Specifications	22
Mechanical Specifications	22
Performance Specifications	22
S-130 Motor Specifications	22
S-180	
Dimensions	31
Electrical Specifications	24
Mechanical Specifications	24
Performance Specifications	24
S-180 Motor Specifications	24
S-240	
Dimensions	32
Electrical Specifications	26
Mechanical Specifications	26
Performance Specifications	26
S-240 Motor Specifications	26
serial number	14
Specifications	18
stabilizing stage	15
stage	
stabilizing	15
Storage	14
<b>T</b>	
Table of Contents	3
Thermal Protective Device	42
Thermistor Interface Circuit	43
<b>U</b>	
UKCA Declaration of Conformity	8
<b>W</b>	
Warnings	9
Warranty and Field Service	47
Wiring Guidelines	41