



BLM Series "U-Channel" Linear Motor

HARDWARE MANUAL

Revision 3.02



GLOBAL TECHNICAL SUPPORT

Go to the [Global Technical Support Portal](#) for information and support about your Aerotech, Inc. products. The website supplies software, product manuals, Help files, training schedules, and PC-to-PC remote technical support. If necessary, you can complete Product Return (RMA) forms and get information about repairs and spare or replacement parts. To get help immediately, contact a service office or your sales representative. Include your customer order number in your email or have it available before you call.

This manual contains proprietary information and may not be reproduced, disclosed, or used in whole or in part without the express written permission of Aerotech, Inc. Product names mentioned herein are used for identification purposes only and may be trademarks of their respective companies.

Copyright © 1995-2025, Aerotech, Inc. | All rights reserved.

See the latest version of Aerotech's [Terms of Use](#), [Privacy Policy](#), and [Cookie Policy](#) online at aerotech.com.



Table of Contents

BLM Series "U-Channel" Linear Motor	1
Table of Contents	3
List of Figures	4
List of Tables	5
EU Declaration of Conformity	6
UKCA Declaration of Conformity	7
Agency Approvals	8
Safety Procedures and Warnings	9
Installation and Operation	10
Electrical Warnings	11
Motor-Related Warnings	12
Pinch Points	13
Magnetic Hazards	14
Handling and Storage	15
Chapter 1: Overview	17
1.1. Motor Specifications	23
1.2. Dimensions	34
1.3. Environmental Specifications	40
1.4. Air Requirements	41
1.5. Vacuum Operation	42
Chapter 2: Assembly and Installation	43
2.1. Bearing System	44
2.2. Position Transducer Resolution	44
2.3. Cable Management	44
2.4. Mechanical Arrangement of the Magnet Track	45
2.5. Track Stacking	45
2.6. Straightness and Flatness Tolerance	46
2.6.1. BLMSC Tolerances	46
2.6.2. BLMUC Tolerances	47
2.6.3. BLMC Tolerances	48
2.6.4. BLM Tolerances	49
2.6.5. BLMH Tolerances	50
2.6.6. BLMX Tolerances	51
2.7. External Motor Wiring	52
2.7.1. Motor Power Conductors	53
2.7.2. Protective Ground	53
2.7.3. Over-Current Protection	53
2.7.4. Hall-Effect Device and Thermistor Wiring	53
2.7.5. Wiring Guidelines	53
2.7.6. Thermal Protective Device	54
2.8. Hall-Effect Operation and Motor Phasing	56
2.9. Motor Heating	57
Chapter 3: Maintenance	59
Appendix A: Warranty and Field Service	61
Appendix B: Revision History	63
Index	65

List of Figures

Figure 1-1: BLMSC Model Dimensions	34
Figure 1-2: BLMUC Model Dimensions	35
Figure 1-3: BLMC Model Dimensions	36
Figure 1-4: BLM Model Dimensions	37
Figure 1-5: BLMH Model Dimensions	38
Figure 1-6: BLMX Model Dimensions	39
Figure 2-1: Motor Assembled in a Linear Stage	43
Figure 2-2: Linear Motor Mounting Configurations (end view)	45
Figure 2-3: Stacking Tracks	45
Figure 2-4: BLMSC Straightness and Flatness Tolerances	46
Figure 2-5: BLMUC Straightness and Flatness Tolerances	47
Figure 2-6: BLMC Straightness and Flatness Tolerances	48
Figure 2-7: BLM Straightness and Flatness Tolerances	49
Figure 2-8: BLMH Straightness and Flatness Tolerances	50
Figure 2-9: BLMX Straightness and Flatness Tolerances	51
Figure 2-10: Motor Wiring with Flying Leads	52
Figure 2-11: Thermal Sensor Resistance as a Function of Temperature	54
Figure 2-12: Typical Thermistor Interface Circuit	55
Figure 2-13: Linear Motor Phasing	56

List of Tables

Table 1-1: BLMSC Options	17
Table 1-2: BLMUC Options	18
Table 1-3: BLMC Forcer Options	19
Table 1-4: BLM Options	20
Table 1-5: BLMH Options	21
Table 1-6: BLMX Options	22
Table 1-7: BLMSC Motor Specifications	23
Table 1-8: BLMUC Motor Specifications (P Magnet Track)	24
Table 1-9: BLMUC Motor Specifications (S Magnet Track)	25
Table 1-10: BLMC Motor Specifications (P Magnet Track)	26
Table 1-11: BLMC Motor Specifications (S Magnet Track)	27
Table 1-12: BLM Motor Specifications (P Magnet Track, BLM-142, BLM-203, BLM-264)	28
Table 1-13: BLM Motor Specifications (P Magnet Track, BLM-325, BLM-386)	29
Table 1-14: BLM Motor Specifications (S Magnet Track, BLM-142, BLM-203, BLM-264)	30
Table 1-15: BLM Motor Specifications (S Magnet Track, BLM-325, BLM-386)	31
Table 1-16: BLMH Motor Specifications	32
Table 1-17: BLMX Motor Specifications	33
Table 1-18: Environmental Specifications	40
Table 2-1: Bend Radius	44
Table 2-2: Cable Diameter and Wire Gauge (Standard)	52
Table 2-3: Cable Diameter and Wire Gauge (Vacuum)	53

EU Declaration of Conformity

Manufacturer Aerotech, Inc.
Address 101 Zeta Drive
 Pittsburgh, PA 15238-2811
 USA



Declares that the product:

Product BLMSC, BLMUC, BLMC, BLM, BLMH, BLMX Motors (excluding VAC6 versions)
Model/Types All

To which this declaration relates, meets the essential health and safety requirements and is in conformity with the relevant EU Directives listed below:

2014/35/EU	Low Voltage Directive
EU 2015/863	Directive, Restricted Substances (RoHS 3)

Using the relevant section of the following EU Standards and other normative documents:

IEC 60034-1:2010	Rotating electrical machines
IEC 61010-1:2010	Safety requirements for electrical equipment for measurement, control, and laboratory use

NOTE: Safe operation of the motor requires over speed and over current protection. This could be done by the connected controller / amplifier combination.

Authorized Representative:

Managing Director
 Aerotech GmbH
 Gustav-Weißkopf-Str. 18
 90768 Fürth
 Germany

Jochen Jäger

Engineer Verifying Compliance:

Aerotech, Inc.
 101 Zeta Drive
 Pittsburgh, PA 15238-2811
 USA

Matt Maurer

Date: 2/18/2025

UKCA Declaration of Conformity

Manufacturer Aerotech, Inc.
Address 101 Zeta Drive
Pittsburgh, PA 15238-2811
USA



Declares that the product:

Product BLMSC, BLMUC, BLMC, BLM, BLMH, BLMX Motors (excluding VAC6 versions)
Model/Types All

To which this declaration relates, meets the essential health and safety requirements and is in conformity with the relevant UK Legislation listed below:

Electrical Equipment (Safety) Regulations 2016
Hazardous Substances in Electrical and Electronic Equipment Regulations 2012

Using the relevant section of the following UK Designated Standards and other normative documents when installed in accordance with the installation instructions supplied by the manufacturer.

IEC 60034-1:2010 Rotating electrical machines
IEC 61010-1:2010 Safety requirements for electrical equipment for measurement, control, and laboratory use

NOTE: Safe operation of the motor requires over speed and over current protection.
This could be done by the connected controller / amplifier combination.

Authorized Representative:

Managing Director
Aerotech Ltd
The Old Brick Kiln
Ramsdell, Tadley
Hampshire RG26 5PR
UK

Simon Smith

Engineer Verifying Compliance:

Aerotech, Inc.
101 Zeta Drive
Pittsburgh, PA 15238-2811
USA

Matt Maurer

Date: 2/18/2025

Agency Approvals

The BLMSC, BLMUC, BLMC, BLM, BLMH, and BLMX motors and MT-xxx magnet tracks have been tested by the following NRTL(s) and have been certified to the standards that follow:

Approval:	CUS NRTL
Approving Agency:	TÜV SÜD America Inc.
Certificate #:	U10U 068995 0036
Standards:	UL 1004-1:2012/R:2020-11



Visit <https://www.tuev-sued.de/product-testing/certificates> to view Aerotech's TÜV SÜD certificates. Type the certificate number listed above in the search bar or type "Aerotech" for a list of all Aerotech certificates.

Installation Conditions

- Temperature testing to be performed in end use application.
 - The linear motors are rated for Class A operation which limits the operating temperature to 105 °C.
 - The installer or integrator must set the current protection in the servo drive so that the motor temperature does not exceed Class A ratings.
 - This must be tested in the final installation under worst case operating conditions.
- Mechanical/electrical enclosure to be provided by end use product
- The servo drive provided in the end use application must comply with Electrical Safety Standard UL 61800-5-1, IEC 61800-5-1 or similar.
- Installation requirements are pollution degree 2, overvoltage category 1.
- Metal parts exposed to contact by service personnel must be reliably connected to ground in end use application.
- Limited short circuit test to be done in end use application.



IMPORTANT: A UL listed surge protection device must be added to the servo drive's motor supply input to limit the surge voltage according to over voltage category 1. The monitor contacts must be used to determine if a failure of the surge protection element has occurred resulting in loss of protection.

The Littelfuse parts (or equivalent) that follow can be used:

- SPD2-300-2P0-R: Module plus base, 240 VAC nominal, 2 phase with remote monitor
- SPD2-300-M: Module only, 240 VAC nominal with remote monitor

Safety Procedures and Warnings



IMPORTANT: This manual tells you how to carefully and correctly use and operate the motor.

- Read all parts of this manual before you install or operate the motor or before you do maintenance to your system.
- To prevent injury to you and damage to the equipment, obey the precautions in this manual.
- All specifications and illustrations are for reference only and were complete and accurate as of the release of this manual. To find the newest information about this product, refer to www.aerotech.com.

If you do not understand the information in this manual, contact Aerotech Global Technical Support.



IMPORTANT: This product has been designed for light industrial manufacturing or laboratory environments. If the product is used in a manner not specified by the manufacturer:

- The protection provided by the equipment could be impaired.
- The life expectancy of the product could be decreased.

Safety notes and symbols are placed throughout this manual to warn you of the potential risks at the moment of the safety note or if you fail to obey the safety note.



Shock/Electrocution Hazard



Pinch, Shear, or Crush Hazard



General/Conditional Awareness



Rotational Machinery Hazard



Hot Surface Hazard



Pinch/Entanglement Hazard



Magnetic Field Hazard



Trip Hazard



Heavy, Bulky Lifting Hazard



Appropriate Equipment Required



Pressure/Explosive Atmosphere Hazard



Electrostatic Discharge Hazard

A blue circle symbol is an action or tip that you should obey. Some examples include:



General tip



Read the manual/section



Wear personal protective equipment (PPE): Safety Glasses



If applicable, do not lift unassisted



Wear personal protective equipment (PPE): Gloves



Wear personal protective equipment (PPE): Hearing Protection

Installation and Operation

To decrease the risk of damage to the equipment, you must obey the precautions that follow.



IMPORTANT: Aerotech motors are meant to be part of a drive package that consists of an amplifier and a controller. The motor relies on the drive package for fault protection. Do not use these motors in any other way.



DANGER: General Hazard Warning!

This product can produce high forces and move at velocities that could cause injury. The user is responsible for its safe operation. The following general equation is provided to assist with risk assessments in regards to contact and pinch points:

$$Pressure_{Max} \left[\frac{N}{mm^2} \right] = \frac{Force_{Peak} [N]}{Area_{Contact} [mm^2]}$$



WARNING: General Hazard Warning!

- Only trained operators should operate this equipment.
- All service and maintenance must be done by approved personnel.
- Use this product only in environments and operating conditions that are approved in this manual.
- Never install or operate equipment that appears to be damaged.
- Make sure that the product is securely mounted before you operate it.
- Use care when you move the motor or you could negatively affect the performance of it.



WARNING: Trip Hazard!

Route, house, and secure all cables, duct work, air, or water lines. Failure to do so could introduce trip hazards around the system that could result in physical injury or could damage the equipment.

Electrical Warnings

To decrease the risk of electrical shock, injury, death, and damage to the equipment, obey the precautions that follow.



DANGER: Electrical Shock Hazard!

- Motor phase voltage levels could be hazardous live.
- Personnel are protected from hazardous voltages unless electrical interconnections, protective bonding (safety ground), or motor enclosures are compromised.
- Do not connect or disconnect motor interconnections while connected to a live electrical power source.
- Before you set up or do maintenance, disconnect electrical power.
- Make sure that the motor frame is safety grounded with a conductor equal in size to the phase conductors.
- The drive must contain a properly-sized fuse, matched to the motor cable wire size.
- It is the responsibility of the End User/System Integrator to make sure that motors are properly connected and grounded per Engineering Standards and applicable safety requirements.
- It is the responsibility of the End User/System Integrator to configure the system drive or controller within the Aerotech motor electrical and mechanical specifications.

Motor-Related Warnings

Aerotech motors are capable of producing high forces and velocities. Obey all warnings and all applicable codes and standards when you use or operate a stage or system that incorporates Aerotech motors.

DANGER: Mechanical Hazard!

Personnel must be made aware of the mechanical hazards during set up or when you do service to the motor.



- When the system is not electrically energized (disabled), linear motors can still allow a stage carriage to move freely. This can create mechanical hazards such as pinch or crush points.
- Unintentional manual movement into the stage "end-of-travel" stops, could damage the stage or undo precision alignments.
- Motor movement could create pinch points, entanglement hazards, or rotational mechanical hazards.
- Uncouple or otherwise prevent motion of motor-coupled machinery when you do service to the equipment.

DANGER: Hot Surface Hazard!



- The motor frame temperature could exceed 70°C in some applications.
- Do not touch the motor frame while it is in operation.
- Wait until the motor has cooled before you touch it.

DANGER: Risk of Explosive Atmosphere!



- Standard Aerotech motors are not rated for applications with explosive atmospheres such as airborne dust or combustible vapors.
- Do not operate motors outside of Aerotech environmental specifications.

DANGER: Magnetic Field Hazard!



Aerotech motors contain magnets which can present a Magnetic Field Hazard.

- Do not disassemble a motor under any circumstances.
- Strong magnetic fields could interfere with external/internal medical devices.
- Strong magnetic fields could present mechanical hazards such as pinch points.

Pinch Points

A pinch point is a mechanical hazard that can occur when there are exposed parts of the motor, stage, or system that can move. For example, the travel of a stage tabletop could expose the user to a pinch point between the tabletop and the stage housing. The images that follow will show you typical external and internal pinch point locations.

DANGER: Mechanical Hazard!



- System travel can cause crush, shear, or pinch injuries.
- Only trained operators should operate this equipment.
- Do not put yourself in the travel path of machinery.
- Restrict access to all motor parts
 - when the system moves under power (during normal operation, for example).
 - when the system is moved manually (during the installation process or when you do maintenance, for example).
- Motors are capable of very high speeds and acceleration rates.

Figure 1: Typical Pinch Point Locations

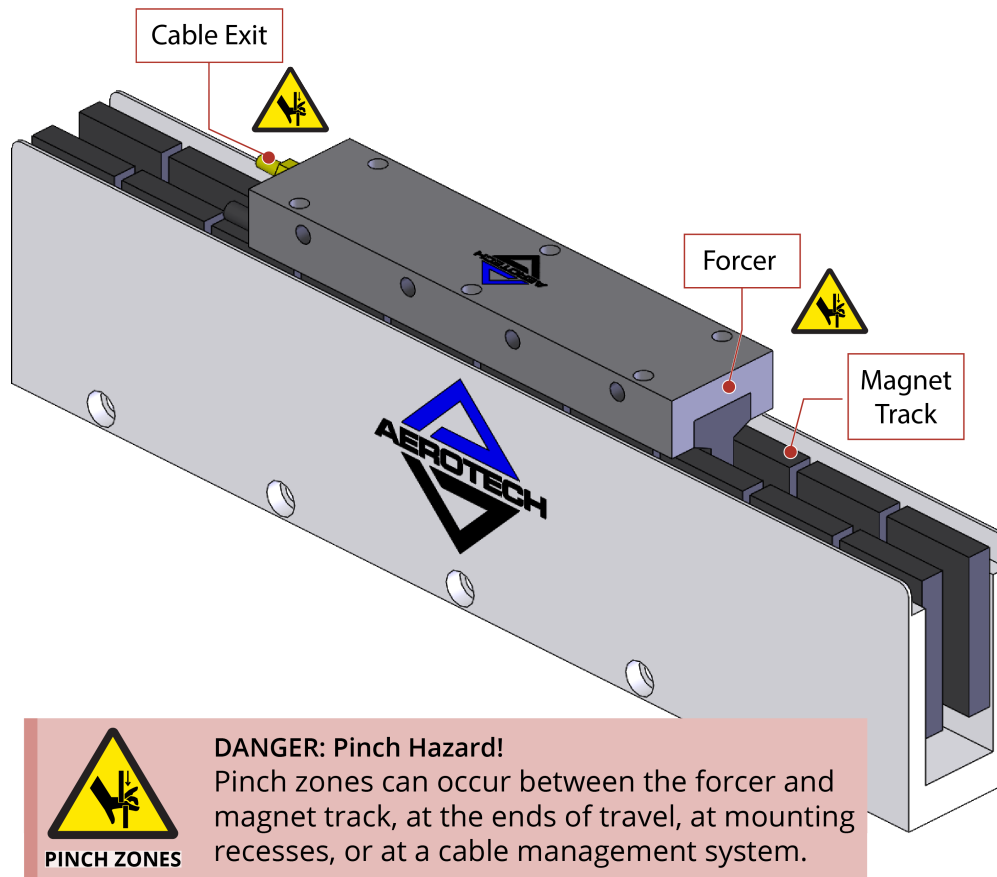

PINCH ZONES

DANGER: Pinch Hazard!

Pinch zones can occur between the forcer and magnet track, at the ends of travel, at mounting recesses, or at a cable management system.

Magnetic Hazards

The magnet track will be exposed during normal operation or when you do maintenance to the system.



DANGER: Magnetic Field Hazard!

- Only qualified, trained personnel should be allowed to have access to exposed magnet tracks during setup or when you do maintenance.
- Strong magnetic fields are present near and inside the magnet track assembly.
- Do not disassemble the magnet track components. If you do so, you will expose yourself to mechanical crush, pinch, or impact hazards.
- Magnetic fields could interfere with external or internal medical devices (pacemakers, for example).
- Magnetic fields can create mechanical hazards (crush, impact, or pinch points, for example).
- Loose items such as metallic tools, watches, or keys could get drawn into and damage the magnet track assembly.



IMPORTANT: Use non-magnetic tools when you install or do service to the stage.

Figure 2: Exposed Magnet Locations

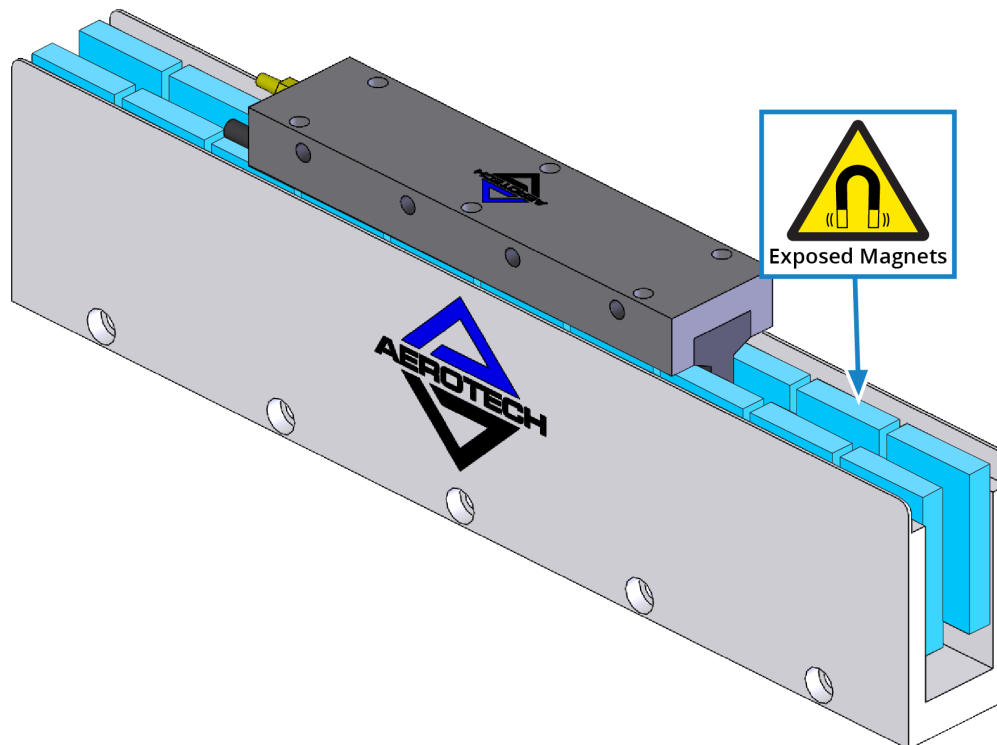

Handling and Storage



IMPORTANT: It is the responsibility of the customer to safely and carefully lift and move the motor.

- Be careful when you move or transport the motor.
- Retain the shipping materials for future use.
- Transport or store the motor in its protective packaging.



WARNING: Electrostatic Discharge (ESD) Sensitive Components!

Wear an ESD wrist strap when you handle, install, or do service to the system assembly.

Failure to observe the correct ESD practices could cause ESD damage to stage electronics, system drives, and/or power supplies.

Inspect the shipping container for any evidence of shipping damage. If any damage exists, notify the shipping carrier immediately.

Remove the packing list from the shipping container. Make sure that all the items specified on the packing list are contained within the package.

The documentation for the motor is on the included installation device. The documents include manuals, interconnection drawings, and other system documentation. Save this information for future reference.

Each motor has a label listing the system part number and serial number. These numbers contain information necessary for maintenance or system hardware and software updates. Locate this label and record the information for later reference.

Unpacking and Handling

It is the responsibility of the customer to safely and carefully lift and move the motor.



IMPORTANT: All electronic equipment and instrumentation is wrapped in antistatic material and packaged with desiccant. Ensure that the antistatic material is not damaged during unpacking.



DANGER: Lifting Hazard! Use care when you move the motor or you could negatively affect the performance of it.

- Use the correct lifting techniques, mechanical assistance, or additional help to lift or move this product.
- Do not use the cables or the connectors to lift or move this product.
- Make sure that all moving parts are secure before you move the motor. Unsecured moving parts could shift and cause injury or damage to the equipment.
- If the motor is heavy, a single person lift could cause injury. Use assistance when you lift or move it.
 - Refer to [Section 1.2. Dimensions](#) for dimensions
 - Refer to [Section 1.1. Motor Specifications](#) for weight specifications.

Carefully remove the motor from its protective shipping container.

- Lift this product only by the base.
- Use a cart, dolly, or similar device to move the motor to a new location.

Gently set the motor on a smooth, flat, and clean surface. Use compressed nitrogen or clean, dry, oil-free air to remove any dust or debris that has collected during shipping.

Before you operate the motor, let it stabilize at room temperature for at least 12 hours. This will ensure that all of the alignments, preloads, and tolerances are the same as they were when they were tested at Aerotech.

Storage

Store the motor in the original shipping container. If the original packaging included ESD protective packaging, make sure to store the motor in it. The storage location must be dry, free of dust, free of vibrations, and flat.

Refer to [Section 1.3. Environmental Specifications](#)

Chapter 1: Overview

Table 1-1: BLMSC Options

BLMSC Brushless Linear Servomotor	
BLMSC-111	111 mm long linear motor forcer with thermistor
Winding Option (Required)	
-A	Standard
Cooling Option (Required)	
-NC	No air cooling (standard)
Hall-Effect Sensor Options (Required)	
-NH	No Hall-effect sensors
-H	With Hall-effect sensors
Cable Length Options (Required)	
-750	750 mm of high-flex cable
-5000	5.0 m of high-flex cable
Magnet Track Options (Optional)	
MTSC64P	64 mm long magnet track
MTSC96P	96 mm long magnet track
MTSC112P	112 mm long magnet track
MTSC128P	128 mm long magnet track
MTSC144P	144 mm long magnet track
MTSC160P	160 mm long magnet track
MTSC192P	192 mm long magnet track
MTSC224P	224 mm long magnet track
MTSC256P	256 mm long magnet track
MTSC288P	288 mm long magnet track
MTSC352P	352 mm long magnet track
MTSC400P	400 mm long magnet track
MTSC416P	416 mm long magnet track
MTSC#P	Custom length magnet track
NOTE: Magnet tracks are ordered as separate line items.	

Table 1-2: BLMUC Options

BLMUC Brushless Linear Servomotor	
BLMUC-79	79 mm long linear motor forcer with thermistor
BLMUC-95	95 mm long linear motor forcer with thermistor
BLMUC-111	111 mm long linear motor forcer with thermistor
BLMUC-143	143 mm long linear motor forcer with thermistor
Winding Option (Required)	
-A	Standard
Cooling Options (Required)	
-NC	No air-cooling fitting
-AC	With air-cooling fitting; not available with -V option
Hall-Effect Sensor Options (Required)	
-NH	No Hall-effect sensors
-H	With Hall-effect sensors
Motor Preparation Options (Required)	
-S	Standard motor preparation
-V	Vacuum preparation for 10^{-6} Torr
-UHV	Ultra-high vacuum preparation, contact the factory
Cable Length Options (Required)	
-750	750 mm of high-flex cable
-5000	5.0 m of high-flex cable
Magnet Track Options (Optional)	
MTUC64P/S	64 mm long magnet track
MTUC96P/S	96 mm long magnet track
MTUC128P/S	128 mm long magnet track
MTUC160P/S	160 mm long magnet track
MTUC192P/S	192 mm long magnet track
MTUC224P/S	224 mm long magnet track
MTUC256P/S	256 mm long magnet track
MTUC288P/S	288 mm long magnet track
MTUC352P/S	352 mm long magnet track
MTUC416P/S	416 mm long magnet track
MTUC#P/S	Custom length magnet track
<p>NOTE: Magnet tracks are ordered as separate line items.</p> <ul style="list-style-type: none"> Magnet track part numbers ending with "P" are high performance grade and include magnets on both sides of the track. Example: MTUC64P Magnet track numbers ending with "S" are standard performance grade and include magnets on a single side of the track. Example: MTUC96S 	

Table 1-3: BLMC Forcer Options

BLMC Brushless Linear Servomotor	
BLMC-92	92 mm long linear motor forcer with thermistor
BLMC-142	142 mm long linear motor forcer with thermistor
BLMC-192	192 mm long linear motor forcer with thermistor
BLMC-267	267 mm long linear motor forcer with thermistor
Winding Option (Required)	
-A	Standard
Cooling Options (Required)	
-NC	No air-cooling fitting
-ACC	With a rear center air-cooling fitting; not available with -V option
-ACL	With a rear left-side air-cooling fitting; not available with -V option
-ACR	With a rear right-side air-cooling fitting; not available with -V option
Hall-Effect Sensor Options (Required)	
-NH	No Hall-effect sensors
-H	With Hall-effect sensors
Motor Preparation Options (Required)	
-S	Standard motor preparation
-V	Vacuum preparation for 10^{-6} Torr
-UHV	Ultra-high vacuum preparation, contact the factory
Cable Length Options (Required)	
-750	750 mm of high-flex cable
-5000	5.0 m of high-flex cable
Magnet Track Options (Optional)	
MTC100P/S	100 mm long compact magnet track
MTC150P/S	150 mm long compact magnet track
MTC200P/S	200 mm long compact magnet track
MTC250P/S	250 mm long compact magnet track
MTC300P/S	300 mm long compact magnet track
MTC350P/S	350 mm long compact magnet track
MTC450P/S	450 mm long compact magnet track
MTC500P/S	500 mm long compact magnet track
MTC#P/S	Custom length compact magnet track
NOTE: Magnet tracks are ordered as separate line items.	
<ul style="list-style-type: none"> Magnet track part numbers ending with "P" are high performance grade and include magnets on both sides of the track. Example: MTC300P Magnet track numbers ending with "S" are standard performance grade and include magnets on a single side of the track. Example: MTC350S 	

Table 1-4: BLM Options

BLM Brushless Linear Servomotor	
BLM-142	142 mm long linear motor forcer with thermistor
BLM-203	203 mm long linear motor forcer with thermistor
BLM-264	264 mm long linear motor forcer with thermistor
BLM-325	325 mm long linear motor forcer with thermistor
BLM-386	386 mm long linear motor forcer with thermistor
BLM-X	Custom length linear motor forcer with thermistor
Winding Options (Required)	
-A	Standard
NOTE: Alternate winding options are available. Contact Aerotech for more information.	
Cooling Options (Required)	
-NC	No air-cooling fitting
-AC	With air-cooling fitting; not available with -V option
Hall-Effect Sensor Options (Required)	
-NH	No Hall-effect sensors
-H	With Hall-effect sensors
Motor Preparation Options (Required)	
-S	Standard motor preparation
-V	Vacuum preparation for 10^{-6} Torr
-UHV	Ultra-high vacuum preparation, contact the factory
Cable Length Options (Required)	
-750	750 mm of high-flex cable
-5000	5.0 m of high-flex cable
Magnet Track Options (Optional)	
MT180P/S	180 mm length magnet track
MT240P/S	240 mm length magnet track
MT300P/S	300 mm length magnet track
MT360P/S	360 mm length magnet track
MT420P/S	420 mm length magnet track
MT480P/S	480 mm length magnet track
MT540P/S	540 mm length magnet track
MT600P/S	600 mm length magnet track
MT#/P/S	Custom length magnet track
NOTE: Magnet tracks are ordered as separate line items.	
<ul style="list-style-type: none"> Magnet track part numbers ending with "P" are high performance grade and include magnets on both sides of the track. Example: MT360P Magnet track numbers ending with "S" are standard performance grade and include magnets on a single side of the track. Example: MT420S 	

Table 1-5: BLMH Options

BLMH Brushless Linear Servomotor	
BLMH-142	142 mm long linear motor forcer with thermistor
BLMH-262	262 mm long linear motor forcer with thermistor
BLMH-382	382 mm long linear motor forcer with thermistor
Winding Options (Required)	
-A	Standard
NOTE: Alternate winding options are available. Contact Aerotech for more information.	
Cooling Options (Required)	
-NC	No air-cooling fitting
-AC	With air-cooling fitting; not available with -V option
Hall-Effect Sensor Options (Required)	
-NH	No Hall-effect sensors
-H	With Hall-effect sensors
Motor Preparation Options (Required)	
-S	Standard motor preparation
-V	Vacuum preparation for 10^{-6} Torr
-UHV	Ultra-high vacuum preparation, contact the factory
Bus Voltage Selection	
-VT1	Low voltage model
-VT2	High voltage model
Cable Length Options (Required)	
-750	750 mm of high-flex cable
-5000	5.0 m of high-flex cable
Magnet Track Options (Optional)	
MTH180P	180 mm long magnet track
MTH240P	240 mm long magnet track
MTH300P	300 mm long magnet track
MTH360P	360 mm long magnet track
MTH480P	480 mm long magnet track
MTH600P	600 mm long magnet track
MTH720P	720 mm long magnet track
MTH#P	Custom length magnet track
NOTE: Magnet tracks are ordered as separate line items.	

Table 1-6: BLMX Options

BLMX Brushless Linear Servomotor	
BLMX-382	382 mm long linear motor forcer with thermistor
BLMX-502	502 mm long linear motor forcer with thermistor
Winding Options (Required)	
-A	Standard
NOTE: Alternate winding options are available. Contact Aerotech for more information.	
Cooling Options (Required)	
-NC	No air-cooling fitting
-AC	With air-cooling fitting; not available with -V option
Hall-Effect Sensor Options (Required)	
-NH	No Hall-effect sensors
-H	With Hall-effect sensors
Motor Preparation Options (Required)	
-S	Standard motor preparation
-V	Vacuum preparation for 10^{-6} Torr
-UHV	Ultra-high vacuum preparation, contact the factory
Bus Voltage Selection	
-VT1	Low voltage model
-VT2	High voltage model
Cable Length Options (Required)	
-750	750 mm of high-flex cable
-5000	5.0 m of high-flex cable
Magnet Track Options (Optional)	
MTX480P	480 mm (18.9 in) long magnet track
MTX600P	600 mm (23.6 in) long magnet track
MTX720P	720 mm (28.4 in) long magnet track
MTX#P	Custom length magnet track
NOTE: Magnet tracks are ordered as separate line items.	

1.1. Motor Specifications

Table 1-7: BLMSC Motor Specifications

		BLMSC-111
Performance Specifications		
Continuous Force	N	20.8
Peak Force	N	83.3
Electrical Specifications		
BEMF Constant (line-line, max)	V/(m/s)	9.2
Continuous Current	A	2.67
Peak Current, Stall	A	10.68
Force Constant, Sine Drive	N/A	7.8
Motor Constant	N/√W	2.91
Resistance, 25 °C (line-line)	Ω	6.8
Inductance (line-line)	mH	1.02
Thermal Resistance	°C/W	1.95
Maximum Bus Voltage	VDC	340
Mechanical Specifications		
Coil Weight	kg	0.13
Coil Length	mm	111
Heat Sink	mm ³	250×250×25
Magnet Track Weight	kg/m	2.81
Magnetic Pole Pitch	mm	16.0
<p>(1) Performance is dependent upon heat sink configuration, system cooling conditions, and ambient temperature.</p> <p>(2) All performance and electrical specifications have a tolerance of ±10%.</p> <p>(3) Values shown @ 100 °C rise above a 25 °C ambient temperature, with motor mounted to the specified aluminum heat sink.</p> <p>(4) Peak force assumes correct rms current; consult Aerotech.</p> <p>(5) Force constant and motor constant specified at stall</p> <p>(6) All Aerotech amplifiers are rated A_{pk}; use force constant in N/A_{pk} when sizing.</p> <p>(7) All Aerotech motors and amplifiers are rated using vector amplitude values. For sinusoidal signals, use sine wave peak value.</p>		

Table 1-8: BLMUC Motor Specifications (P Magnet Track)

		BLMUC-79	BLMUC-95	BLMUC-111	BLMUC-143
Performance Specifications					
Continuous Force, 1.4 bar (20 psi)	N	31.4	40.5	46.9	58.0
Continuous Force, No Forced Cooling	N	18.3	23.0	30.6	39.8
Peak Force	N	125.4	161.9	187.6	231.8
Electrical Specifications					
BEMF Constant (line-line, max)	V/(m/s)	6.80	9.00	11.35	15.90
Continuous Current 1.4 bar (20 psi)	A	5.30	5.17	4.75	4.19
Continuous Current, No Forced Cooling	A	3.10	2.94	3.10	2.88
Peak Current, Stall	A	21.20	20.68	19.00	16.76
Force Constant, Sine Drive	N/A	5.92	7.83	9.87	13.83
Motor Constant	N/√W	2.89	3.35	3.78	4.53
Resistance, 25 °C (line-line)	Ω	4.0	5.2	6.5	8.9
Inductance (line-line)	mH	0.51	0.70	0.87	1.10
Thermal Resistance, 1.4 bar (20 psi)	°C/W	0.85	0.69	0.65	0.61
Thermal Resistance, No Forced Cooling	°C/W	2.48	2.12	1.52	1.29
Maximum Bus Voltage	VDC	340	340	340	340
Mechanical Specifications					
Air Flow, 20 psi	m ³ /s	1.5 × 10 ⁻³	1.5 × 10 ⁻³	1.5 × 10 ⁻³	1.5 × 10 ⁻³
Coil Weight	kg	0.10	0.12	0.14	0.20
Coil Length	mm	80.0	96.0	112.0	144.0
Heat Sink	mm ³	250×250×25	250×250×25	250×250×25	250×250×25
Magnet Track Weight	kg/m	3.33	3.33	3.33	3.33
Magnetic Pole Pitch	mm	16.00	16.00	16.00	16.00
<p>(1) Performance is dependent upon heat sink configuration, system cooling conditions, and ambient temperature.</p> <p>(2) All performance and electrical specifications have a tolerance of ±10%.</p> <p>(3) Values shown @ 100 °C rise above a 25 °C ambient temperature, with motor mounted to the specified aluminum heat sink.</p> <p>(4) Peak force assumes correct rms current; consult Aerotech.</p> <p>(5) Force constant and motor constant specified at stall</p> <p>(6) All Aerotech amplifiers are rated A_{pk}; use force constant in N/A_{pk} when sizing.</p> <p>(7) All Aerotech motors and amplifiers are rated using vector amplitude values. For sinusoidal signals, use sine wave peak value.</p>					

Table 1-9: BLMUC Motor Specifications (S Magnet Track)

		BLMUC-79	BLMUC-95	BLMUC-111	BLMUC-143
Performance Specifications					
Continuous Force, 1.4 bar (20 psi)	N	20.7	26.7	31.0	38.3
Continuous Force, No Forced Cooling	N	12.1	15.2	20.2	26.3
Peak Force	N	82.8	106.8	123.8	153.0
Electrical Specifications					
BEMF Constant (line-line, max)	V/(m/s)	4.49	5.94	7.49	10.49
Continuous Current 1.4 bar (20 psi)	A	5.30	5.17	4.75	4.19
Continuous Current, No Forced Cooling	A	3.10	2.94	3.10	2.88
Peak Current, Stall	A	21.20	20.68	19.00	16.76
Force Constant, Sine Drive	N/A	3.90	5.17	6.52	9.13
Motor Constant	N/√W	1.91	2.21	2.49	2.99
Resistance, 25 °C (line-line)	Ω	4.0	5.2	6.5	8.9
Inductance (line-line)	mH	0.51	0.70	0.87	1.10
Thermal Resistance, 1.4 bar (20 psi)	°C/W	0.85	0.69	0.65	0.61
Thermal Resistance, No Forced Cooling	°C/W	2.48	2.12	1.52	1.29
Maximum Bus Voltage	VDC	340	340	340	340
Mechanical Specifications					
Air Flow, 20 psi	m ³ /s	1.5 × 10 ⁻³	1.5 × 10 ⁻³	1.5 × 10 ⁻³	1.5 × 10 ⁻³
Coil Weight	kg	0.10	0.12	0.14	0.20
Coil Length	mm	80.0	96.0	112.0	144.0
Heat Sink	mm ³	250×250×25	250×250×25	250×250×25	250×250×25
Magnet Track Weight	kg/m	3.59	3.59	3.59	3.59
Magnetic Pole Pitch	mm	16.00	16.00	16.00	16.00
(1) Performance is dependent upon heat sink configuration, system cooling conditions, and ambient temperature. (2) All performance and electrical specifications have a tolerance of ±10%. (3) Values shown @ 100 °C rise above a 25 °C ambient temperature, with motor mounted to the specified aluminum heat sink. (4) Peak force assumes correct rms current; consult Aerotech. (5) Force constant and motor constant specified at stall (6) All Aerotech amplifiers are rated A _{pk} ; use force constant in N/A _{pk} when sizing. (7) All Aerotech motors and amplifiers are rated using vector amplitude values. For sinusoidal signals, use sine wave peak value.					

Table 1-10: BLMC Motor Specifications (P Magnet Track)

		BLMC-92	BLMC-142	BLMC-192	BLMC-267
Performance Specifications					
Continuous Force, 1.4 bar (20 psi)	N	75.1	120.3	154.7	184.0
Continuous Force, No Forced Cooling	N	44.5	77.7	106.7	123.5
Peak Force	N	300.6	481.2	618.8	736.0
Electrical Specifications					
BEMF Constant (line-line, max)	V/(m/s)	11.37	21.28	30.66	41.15
Continuous Current 1.4 bar (20 psi)	A	7.60	6.50	5.80	5.14
Continuous Current, No Forced Cooling	A	4.50	4.20	4.00	3.45
Peak Current, Stall	A	30.40	26.00	23.20	20.56
Force Constant, Sine Drive	N/A	9.89	18.51	26.67	35.80
Motor Constant	N/ \sqrt{W}	5.67	8.24	10.29	11.52
Resistance, 25 °C (line-line)	Ω	2.9	4.8	6.4	9.2
Inductance (line-line)	mH	0.83	1.33	1.90	3.40
Thermal Resistance, 1.4 bar (20 psi)	°C/W	0.57	0.47	0.44	0.39
Thermal Resistance, No Forced Cooling	°C/W	1.62	1.12	0.93	0.87
Maximum Bus Voltage	VDC	340	340	340	340
Mechanical Specifications					
Air Flow, 20 psi	m ³ /s	1.4×10^{-3}	1.7×10^{-3}	1.4×10^{-3}	1.5×10^{-3}
Coil Weight	kg	0.16	0.26	0.34	0.52
Coil Length	mm	91.0	142.0	192.0	267.0
Heat Sink	mm ³	250x250x25	250x250x25	250x250x25	250x250x25
Magnet Track Weight	kg/m	6.59	6.59	6.59	6.59
Magnetic Pole Pitch	mm	25	25	25	25
<p>(1) Performance is dependent upon heat sink configuration, system cooling conditions, and ambient temperature.</p> <p>(2) All performance and electrical specifications have a tolerance of $\pm 10\%$.</p> <p>(3) Values shown @ 100 °C rise above a 25 °C ambient temperature, with motor mounted to the specified aluminum heat sink.</p> <p>(4) Peak force assumes correct rms current; consult Aerotech.</p> <p>(5) Force constant and motor constant specified at stall</p> <p>(6) All Aerotech amplifiers are rated A_{pk}; use force constant in N/A_{pk} when sizing.</p> <p>(7) All Aerotech motors and amplifiers are rated using vector amplitude values. For sinusoidal signals, use sine wave peak value.</p>					

Table 1-11: BLMC Motor Specifications (S Magnet Track)

		BLMC-92	BLMC-142	BLMC-192	BLMC-267
Performance Specifications					
Continuous Force, 1.4 bar (20 psi)	N	54.1	86.6	111.4	132.5
Continuous Force, No Forced Cooling	N	32.0	56.0	76.8	88.9
Peak Force	N	216.4	346.5	445.5	529.9
Electrical Specifications					
BEMF Constant (line-line, max)	V/(m/s)	8.18	15.32	22.07	29.63
Continuous Current 1.4 bar (20 psi)	A	7.60	6.50	5.80	5.14
Continuous Current, No Forced Cooling	A	4.50	4.20	4.00	3.45
Peak Current, Stall	A	30.40	26.00	23.20	20.56
Force Constant, Sine Drive	N/A	7.12	13.33	19.20	25.78
Motor Constant	N/√W	4.08	5.94	7.41	8.29
Resistance, 25 °C (line-line)	Ω	2.9	4.8	6.4	9.2
Inductance (line-line)	mH	0.83	1.33	1.90	3.40
Thermal Resistance, 1.4 bar (20 psi)	°C/W	0.57	0.47	0.44	0.39
Thermal Resistance, No Forced Cooling	°C/W	1.62	1.12	0.93	0.87
Maximum Bus Voltage	VDC	340	340	340	340
Mechanical Specifications					
Air Flow, 20 psi	m ³ /s	1.4 × 10 ⁻³	1.7 × 10 ⁻³	1.4 × 10 ⁻³	1.5 × 10 ⁻³
Coil Weight	kg	0.16	0.26	0.34	0.52
Coil Length	mm	91.0	142.0	192.0	267.0
Heat Sink	mm ³	250×250×25	250×250×25	250×250×25	250×250×25
Magnet Track Weight	kg/m	7.11	7.11	7.11	7.11
Magnetic Pole Pitch	mm	25	25	25	25
<p>(1) Performance is dependent upon heat sink configuration, system cooling conditions, and ambient temperature.</p> <p>(2) All performance and electrical specifications have a tolerance of ±10%.</p> <p>(3) Values shown @ 100 °C rise above a 25 °C ambient temperature, with motor mounted to the specified aluminum heat sink.</p> <p>(4) Peak force assumes correct rms current; consult Aerotech.</p> <p>(5) Force constant and motor constant specified at stall</p> <p>(6) All Aerotech amplifiers are rated A_{pk}; use force constant in N/A_{pk} when sizing.</p> <p>(7) All Aerotech motors and amplifiers are rated using vector amplitude values. For sinusoidal signals, use sine wave peak value.</p>					

Table 1-12: BLM Motor Specifications (P Magnet Track, BLM-142, BLM-203, BLM-264)

		BLM-142		BLM-203		BLM-264	
Performance Specifications							
Winding Designation		-A	-B	-A	-B	-A	-B
Continuous Force, 1.4 bar (20 psi)	N	173.2	158.7	251.6		301.7	
Continuous Force, No Forced Cooling	N	110.5		153.3		197.2	
Peak Force	N	692.7		1,006.4		1,206.6	
Electrical Specifications							
Winding Designation		-A	-B	-A	-B	-A	-B
BEMF Constant (line-line, max)	V/(m/s)	40.96	20.48	33.24	66.49	44.46	88.91
Continuous Current 1.4 bar (20 psi)	A	4.86	8.91	8.70	4.35	7.80	3.90
Continuous Current, No Forced Cooling	A	3.1	6.20	5.30	2.65	5.10	2.55
Peak Current, Stall	A	19.44	38.88	34.80	17.40	31.20	15.60
Force Constant, Sine Drive	N/A	35.63	17.82	28.92	57.84	38.67	77.35
Motor Constant	N/√W	10.53		14.11		16.39	
Resistance, 25 °C (line-line)	Ω	10.9	2.7	4.0	16.0	5.3	21.2
Inductance (line-line)	mH	8.70	2.18	3.20	12.80	4.20	16.80
Thermal Resistance, 1.4 bar (20 psi)	°C/W	0.37		0.31		0.30	
Thermal Resistance, No Forced Cooling	°C/W	0.91		0.85		0.69	
Maximum Bus Voltage	VDC	340		340		340	
Mechanical Specifications							
Air Flow, 20 psi	m ³ /s	1.7 × 10 ⁻³		1.5 × 10 ⁻³		1.6 × 10 ⁻³	
Coil Weight	kg	0.60		0.90		1.10	
Coil Length	mm	143.8		204.7		265.7	
Heat Sink	mm ³	250×250×25		250×250×25		250×250×25	
Magnet Track Weight	kg/m	10.12		10.12		10.12	
Magnetic Pole Pitch	mm	30.48		30.48		30.48	
<p>(1) Performance is dependent upon heat sink configuration, system cooling conditions, and ambient temperature.</p> <p>(2) All performance and electrical specifications have a tolerance of ±10%.</p> <p>(3) Values shown @ 100 °C rise above a 25 °C ambient temperature, with motor mounted to the specified aluminum heat sink.</p> <p>(4) Peak force assumes correct rms current; consult Aerotech.</p> <p>(5) Force constant and motor constant specified at stall</p> <p>(6) All Aerotech amplifiers are rated A_{pk}; use force constant in N/A_{pk} when sizing.</p> <p>(7) All Aerotech motors and amplifiers are rated using vector amplitude values. For sinusoidal signals, use sine wave peak value.</p>							

Table 1-13: BLM Motor Specifications (P Magnet Track, BLM-325, BLM-386)

		BLM-325		BLM-386	
Performance Specifications					
Winding Designation		-A	-B	-A	-B
Continuous Force, 1.4 bar (20 psi)	N	332.2		397.6	
Continuous Force, No Forced Cooling	N	230.7		257.3	
Peak Force	N	1,328.6		1,590.4	
Electrical Specifications					
Winding Designation		-A	-B	-A	-B
BEMF Constant (line-line, max)	V/(m/s)	53.03	106.6	67.21	134.42
Continuous Current 1.4 bar (20 psi)	A	7.20	3.60	6.80	3.40
Continuous Current, No Forced Cooling	A	5.00	2.50	4.40	2.20
Peak Current, Stall	A	28.80	14.40	27.20	13.60
Force Constant, Sine Drive	N/A	46.13	92.27	58.47	116.94
Motor Constant	N/√W	17.66		20.17	
Resistance, 25 °C (line-line)	Ω	6.5	26.0	8.0	32.0
Inductance (line-line)	mH	5.20	20.80	6.20	24.80
Thermal Resistance, 1.4 bar (20 psi)	°C/W	0.28		0.26	
Thermal Resistance, No Forced Cooling	°C/W	0.59		0.61	
Maximum Bus Voltage	VDC	340		340	
Mechanical Specifications					
Air Flow, 20 psi	m ³ /s	1.6 × 10 ⁻³		1.6 × 10 ⁻³	
Coil Weight	kg	1.40		1.70	
Coil Length	mm	326.6		387.6	
Heat Sink	mm ³	250×400×25		250×400×25	
Magnet Track Weight	kg/m	10.12		10.12	
Magnetic Pole Pitch	mm	30.48		30.48	
(1) Performance is dependent upon heat sink configuration, system cooling conditions, and ambient temperature. (2) All performance and electrical specifications have a tolerance of ±10%. (3) Values shown @ 100 °C rise above a 25 °C ambient temperature, with motor mounted to the specified aluminum heat sink. (4) Peak force assumes correct rms current; consult Aerotech. (5) Force constant and motor constant specified at stall (6) All Aerotech amplifiers are rated A _{pk} ; use force constant in N/A _{pk} when sizing. (7) All Aerotech motors and amplifiers are rated using vector amplitude values. For sinusoidal signals, use sine wave peak value.					

Table 1-14: BLM Motor Specifications (S Magnet Track, BLM-142, BLM-203, BLM-264)

		BLM-142		BLM-203		BLM-264	
Performance Specifications							
Winding Designation		-A	-B	-A	-B	-A	-B
Continuous Force, 1.4 bar (20 psi)	N	108.9	99.8	158.2		189.6	
Continuous Force, No Forced Cooling	N	69.4		96.4		124.0	
Peak Force	N	435.5		632.7		758.6	
Electrical Specifications							
Winding Designation		-A	-B	-A	-B	-A	-B
BEMF Constant (line-line, max)	V/(m/s)	25.75	12.88	20.90	41.80	27.95	55.90
Continuous Current 1.4 bar (20 psi)	A	4.86	8.91	8.70	4.35	7.80	3.90
Continuous Current, No Forced Cooling	A	3.10	6.20	5.30	2.65	5.10	2.55
Peak Current, Stall	A	19.44	38.88	34.80	17.40	31.20	15.60
Force Constant, Sine Drive	N/A	22.40	11.20	18.18	36.36	24.31	48.63
Motor Constant	N/√	6.62		8.87		10.31	
Resistance, 25 °C (line-line)	Ω	10.9	2.7	4.0	16.0	5.3	21.2
Inductance (line-line)	mH	8.7	2.2	3.2	12.8	4.2	16.8
Thermal Resistance, 1.4 bar (20 psi)	°C/W	0.37		0.31		0.30	
Thermal Resistance, No Forced Cooling	°C/W	0.91		0.85		0.69	
Maximum Bus Voltage	VDC	340		340		340	
Mechanical Specifications							
Air Flow, 20 psi	m ³ /s	1.7 × 10 ⁻³		1.5 × 10 ⁻³		1.6 × 10 ⁻³	
Coil Weight	kg	0.60		0.90		1.10	
Coil Length	mm	143.8		204.7		265.7	
Heat Sink	mm ³	250×250×25		250×250×25		250×250×25	
Magnet Track Weight	kg/m	10.92		10.92		10.92	
Magnetic Pole Pitch	mm	30.48		30.48		30.48	
<p>(1) Performance is dependent upon heat sink configuration, system cooling conditions, and ambient temperature.</p> <p>(2) All performance and electrical specifications have a tolerance of ±10%.</p> <p>(3) Values shown @ 100 °C rise above a 25 °C ambient temperature, with motor mounted to the specified aluminum heat sink.</p> <p>(4) Peak force assumes correct rms current; consult Aerotech.</p> <p>(5) Force constant and motor constant specified at stall</p> <p>(6) All Aerotech amplifiers are rated A_{pk}; use force constant in N/A_{pk} when sizing.</p> <p>(7) All Aerotech motors and amplifiers are rated using vector amplitude values. For sinusoidal signals, use sine wave peak value.</p>							

Table 1-15: BLM Motor Specifications (S Magnet Track, BLM-325, BLM-386)

		BLM-325		BLM-386	
Performance Specifications					
Winding Designation		-A	-B	-A	-B
Continuous Force, 1.4 bar (20 psi)	N	208.8		250.0	
Continuous Force, No Forced Cooling	N	145.0		161.7	
Peak Force	N	835.3		999.8	
Electrical Specifications					
Winding Designation		-A	-B	-A	-B
BEMF Constant (line-line, max)	V/(m/s)	33.34	66.68	42.25	84.51
Continuous Current 1.4 bar (20 psi)	A	7.20	3.60	6.80	3.40
Continuous Current, No Forced Cooling	A	5.00	2.50	4.40	2.20
Peak Current, Stall	A	28.80	14.40	27.20	13.60
Force Constant, Sine Drive	N/A	29.00	58.01	36.76	73.52
Motor Constant	N/√W	11.10		12.68	
Resistance, 25 °C (line-line)	Ω	6.5	26.0	8.0	32.0
Inductance (line-line)	mH	5.2	20.8	6.2	24.8
Thermal Resistance, 1.4 bar (20 psi)	°C/W	0.28		0.26	
Thermal Resistance, No Forced Cooling	°C/W	0.59		0.61	
Maximum Bus Voltage	VDC	340		340	
Mechanical Specifications					
Air Flow, 20 psi	m ³ /s	1.6 × 10 ⁻³		1.6 × 10 ⁻³	
Coil Weight	kg	1.40		1.70	
Coil Length	mm	326.6		387.6	
Heat Sink	mm ³	250×400×25		250×400×25	
Magnet Track Weight	kg/m	10.92 (7.32)		10.92	
Magnetic Pole Pitch	mm	30.48		30.48	
<p>(1) Performance is dependent upon heat sink configuration, system cooling conditions, and ambient temperature.</p> <p>(2) All performance and electrical specifications have a tolerance of ±10%.</p> <p>(3) Values shown @ 100 °C rise above a 25 °C ambient temperature, with motor mounted to the specified aluminum heat sink.</p> <p>(4) Peak force assumes correct rms current; consult Aerotech.</p> <p>(5) Force constant and motor constant specified at stall</p> <p>(6) All Aerotech amplifiers are rated A_{pk}; use force constant in N/A_{pk} when sizing.</p> <p>(7) All Aerotech motors and amplifiers are rated using vector amplitude values. For sinusoidal signals, use sine wave peak value.</p>					

Table 1-16: BLMH Motor Specifications

		BLMH-142		BLMH-262		BLMH-382	
Performance Specifications							
Winding Designation		-A	-B	-A	-B	-A	-B
Continuous Force, 1.4 bar (20 psi)	N	270.7		437.1		435.8	548.8
Continuous Force, No Forced Cooling	N	150.0		266.2		357.9	
Peak Force	N	1,082.7		1,748.6		2,195.0	
Electrical Specifications							
Winding Designation		-A	-B	-A	-B	-A	-B
BEMF Constant (line-line, max)	V/(m/s)	32.11	64.22	64.42	128.85	45.71	91.42
Continuous Current 1.4 bar (20 psi)	A	9.69	4.85	7.80	3.90	10.96	6.90
Continuous Current, No Forced Cooling	A	5.37	2.69	4.75	2.38	9.00	4.50
Peak Current, Stall	A	38.76	19.38	31.20	15.60	55.20	27.60
Force Constant, Sine Drive	N/A	27.93	55.87	56.04	112.09	39.77	79.53
Motor Constant	N/√W	14.17		20.24		23.19	
Resistance, 25 °C (line-line)	Ω	3.7	14.8	7.3	29.2	2.8	11.2
Inductance (line-line)	mH	2.40	9.60	4.60	18.40	1.80	7.20
Thermal Resistance, 1.4 bar (20 psi)	°C/W	0.27		0.21		0.18	
Thermal Resistance, No Forced Cooling	°C/W	0.89		0.58		0.42	
Maximum Bus Voltage	VDC	VT1: 340 VT2: 680		VT1: 340 VT2: 680		VT1: 340 VT2: 680	
Mechanical Specifications							
Air Flow, 20 psi	m ³ /s	2.5 × 10 ⁻³		2.8 × 10 ⁻³		2.7 × 10 ⁻³	
Coil Weight	kg	1.10		2.10		3.10	
Coil Length	mm	142.0		262.0		382.0	
Heat Sink	mm ³	250×250×25		250×250×25		250×400×25	
Magnet Track Weight	kg/m	20.4		20.4		20.4	
Magnetic Pole Pitch	mm	30.00		30.00		30.00	
<p>(1) Performance is dependent upon heat sink configuration, system cooling conditions, and ambient temperature.</p> <p>(2) All performance and electrical specifications have a tolerance of ±10%.</p> <p>(3) Values shown @ 100 °C rise above a 25 °C ambient temperature, with motor mounted to the specified aluminum heat sink.</p> <p>(4) Peak force assumes correct rms current; consult Aerotech.</p> <p>(5) Force constant and motor constant specified at stall</p> <p>(6) All Aerotech amplifiers are rated A_{pk}; use force constant in N/A_{pk} when sizing.</p> <p>(7) All Aerotech motors and amplifiers are rated using vector amplitude values. For sinusoidal signals, use sine wave peak value.</p>							

Table 1-17: BLMX Motor Specifications

		BLMX-382		BLMX-502	
Performance Specifications					
Winding Designation		-A	-B	-A	-B
Continuous Force, 1.4 bar (20 psi)	N	972		1063	1011
Continuous Force, No Forced Cooling	N	537		601	
Peak Force	N	3,887		4,252	
Electrical Specifications					
Winding Designation		-A	-B	-A	-B
BEMF Constant (line-line, max)	V/(m/s)	86.26	172.52	109.59	54.79
Continuous Current 1.4 bar (20 psi)	A	12.95	6.48	11.15	21.21
Continuous Current, No Forced Cooling	A	7.15	3.58	6.30	12.60
Peak Current, Stall	A	51.80	25.90	44.60	89.20
Force Constant, Sine Drive	N/A	75.04	150.09	95.33	47.67
Motor Constant	N/√W	39.72		46.23	
Resistance, 25 °C (line-line)	Ω	3.4	13.6	4.5	1.1
Inductance (line-line)	mH	3.00	12.00	4.00	1.00
Thermal Resistance, 1.4 bar (20 psi)	°C/W	0.12		0.12	
Thermal Resistance, No Forced Cooling	°C/W	0.40		0.39	
Maximum Bus Voltage	VDC	VT1: 340 VT2: 680		VT1: 340 VT2: 680	
Mechanical Specifications					
Air Flow, 20 psi	m ³ /s	5.4 × 10 ⁻³		5.6 × 10 ⁻³	
Coil Weight	kg	3.40		4.45	
Coil Length	mm	382.0		502.0	
Heat Sink	mm ³	250×400×25		250×500×25	
Magnet Track Weight	kg/m	35.8		35.8	
Magnetic Pole Pitch	mm	30.00		30.00	
(1) Performance is dependent upon heat sink configuration, system cooling conditions, and ambient temperature. (2) All performance and electrical specifications have a tolerance of ±10%. (3) Values shown at 65 °C rise above a 25 °C ambient temperature, with motor mounted to the specified aluminum heat sink. (4) Peak force assumes correct rms current; consult Aerotech. (5) Force constant and motor constant specified at stall (6) All Aerotech amplifiers are rated A _{pk} ; use force constant in N/A _{pk} when sizing. (7) All Aerotech motors and amplifiers are rated using vector amplitude values. For sinusoidal signals, use sine wave peak value.					

1.2. Dimensions

Figure 1-1: BLMSC Model Dimensions

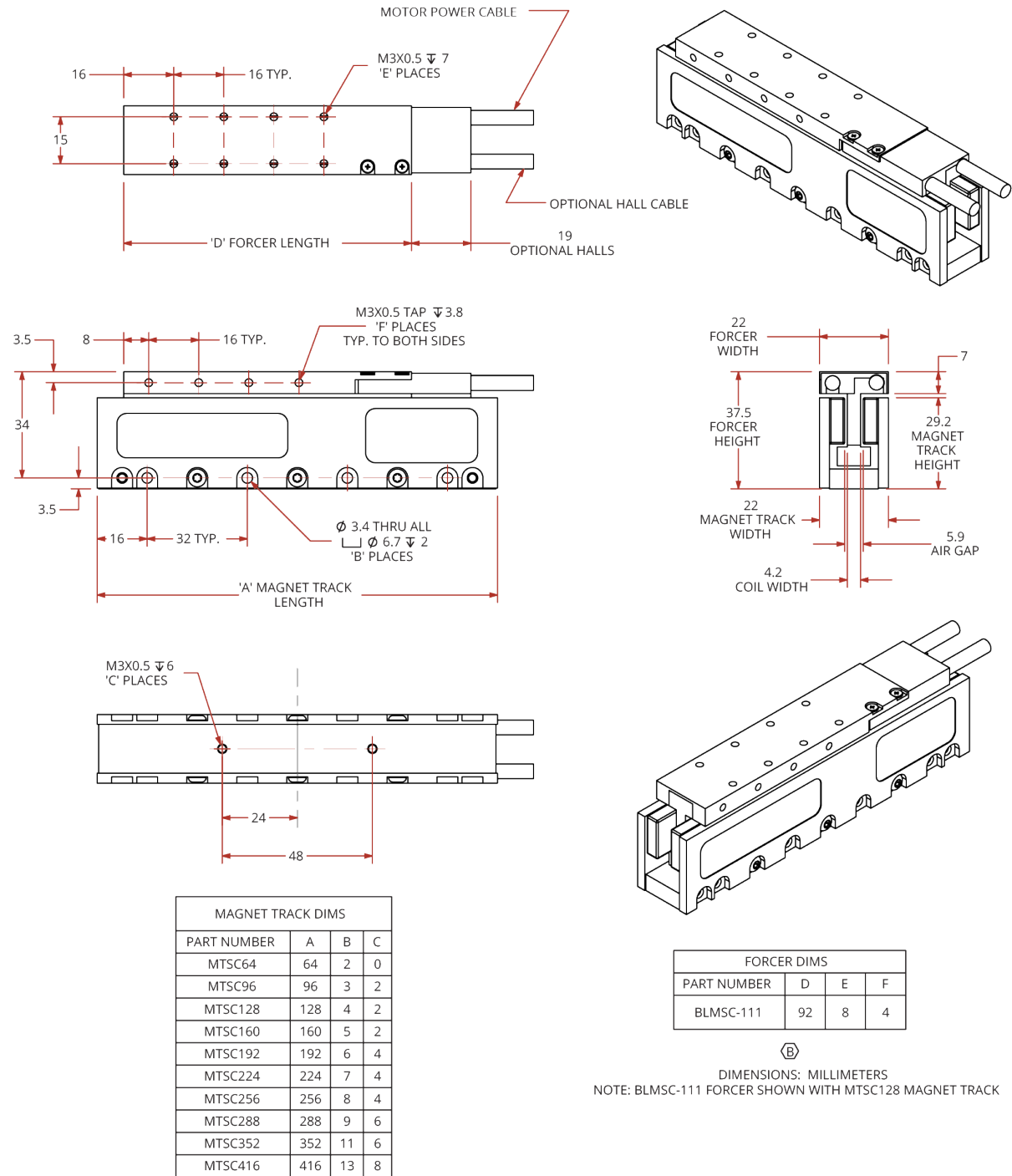
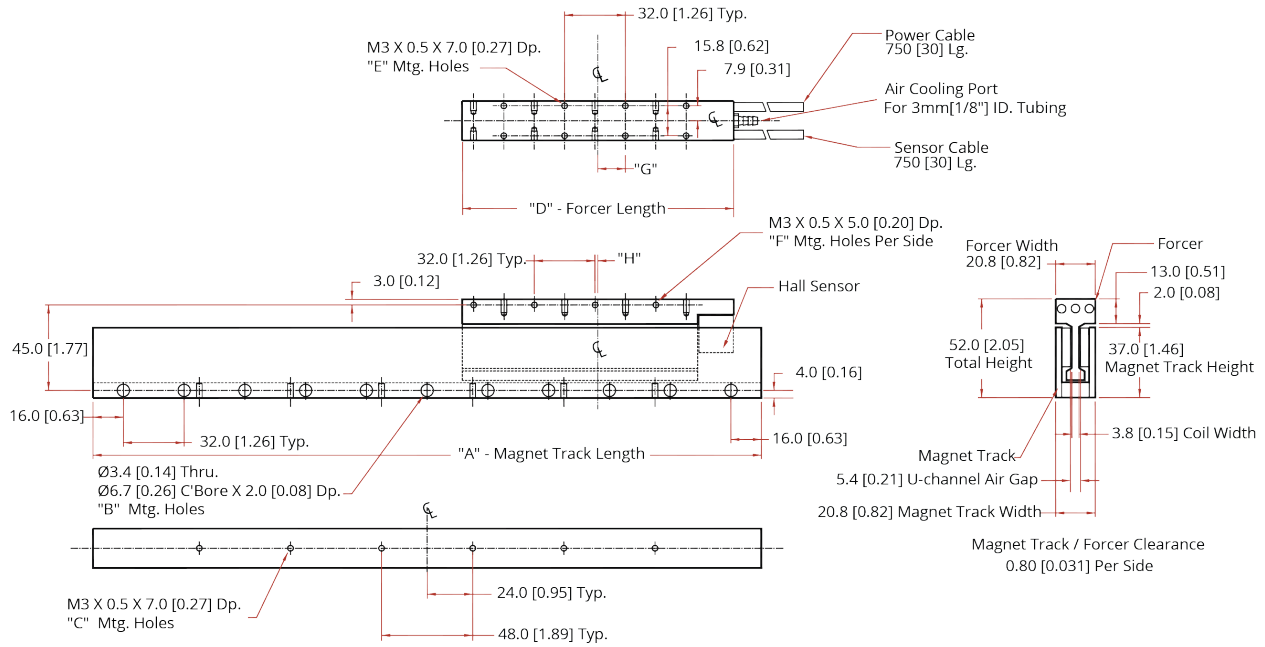

Figure 1-2: BLMUC Model Dimensions



Magnet Track

Model No.	A	B	C
MTUC64	64.0 [2.52]	2	0
MTUC96	96.0 [3.80]	3	2
MTUC128	128.0 [5.04]	4	2
MTUC160	160.0 [6.30]	5	2
MTUC192	192.0 [7.56]	6	4
MTUC224	224.0 [8.82]	7	4
MTUC256	256.0 [10.08]	8	4
MTUC288	288.0 [11.34]	9	6
MTUC352	352.0 [13.86]	11	6
MTUC416	416.0 [16.38]	13	8

Forcer

Model No.	D	E	F	G	H
BLMUC-79	80.0 [3.15]	4	2	14.0 [0.55]	2.0 [0.08]
BLMUC-95	96.0 [3.78]	6	2	22.0 [0.87]	26.0 [1.02]
BLMUC-111	112.0 [4.41]	6	3	30.0 [1.18]	18.0 [0.71]
BLMUC-143	144.0 [5.67]	8	4	14.0 [0.55]	2.0 [0.08]

Dimensions - millimeters [inches]

Figure 1-3: BLMC Model Dimensions

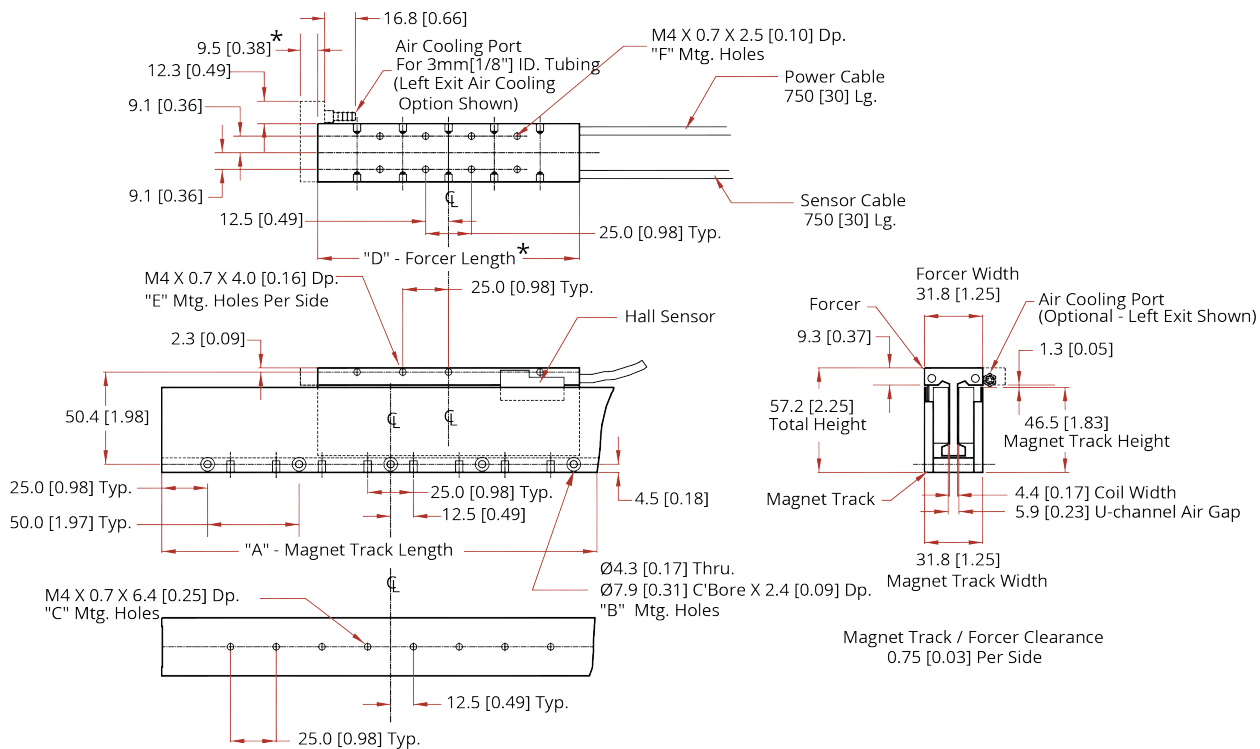

Magnet Track

Model No.	A	B	C
MTC100	100.0 [3.94]	2	4
MTC150	150.0 [5.91]	3	4
MTC200	200.0 [7.87]	4	6
MTC250	250.0 [9.84]	5	8
MTC300	300.0 [11.81]	6	10
MTC350	350.0 [13.78]	7	12
MTC450	450.0 [17.72]	9	16
MTC500	500.0 [19.68]	10	18

Forcer

Model No.	D	E	F
BLMC-92	93.0 [3.66]	2	4
BLMC-142	143.0 [5.63]	5	8
BLMC-192	193.0 [7.60]	7	12
BLMC-267	268.0 [10.55]	8	20

* Add 9.5 [0.38] to forcer length "D" for optional cooling.

Dimensions - millimeters [inches]

Figure 1-4: BLM Model Dimensions

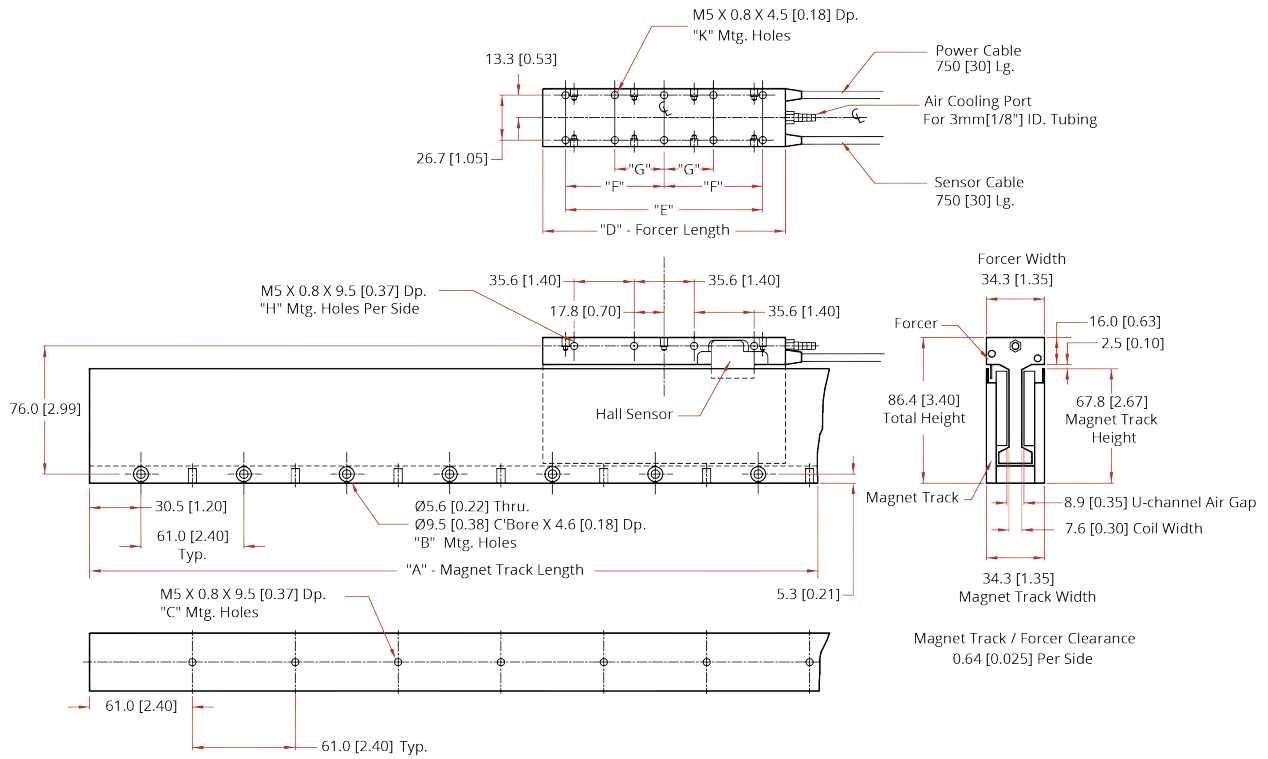

Magnet Track			
Model No.	A	B	C
MT180	182.8 [7.2]	3	2
MT240	243.8 [9.6]	4	3
MT300	304.8 [12.0]	5	4
MT360	365.8 [14.4]	6	5
MT420	426.7 [16.8]	7	6
MT480	487.7 [19.2]	8	7
MT540	548.5 [21.6]	9	8
MT600	609.6 [24.0]	10	9

Forcer						
Model No.	D	E	F	G	H	K
BLM-142	143.8 [5.66]	116.8 [4.60]	58.4 [2.30]	NA	4	6
BLM-203	204.7 [8.06]	177.8 [7.00]	88.9 [3.50]	NA	4	6
BLM-264	265.7 [10.46]	238.8 [9.40]	119.4 [4.70]	NA	6	6
BLM-325	326.6 [12.86]	299.7 [11.80]	149.9 [5.90]	82.7 [3.26]	8	10
BLM-386	387.6 [15.26]	360.6 [14.20]	180.3 [7.10]	96.5 [3.80]	9	10

Dimensions - millimeters [inches]

Figure 1-5: BLMH Model Dimensions

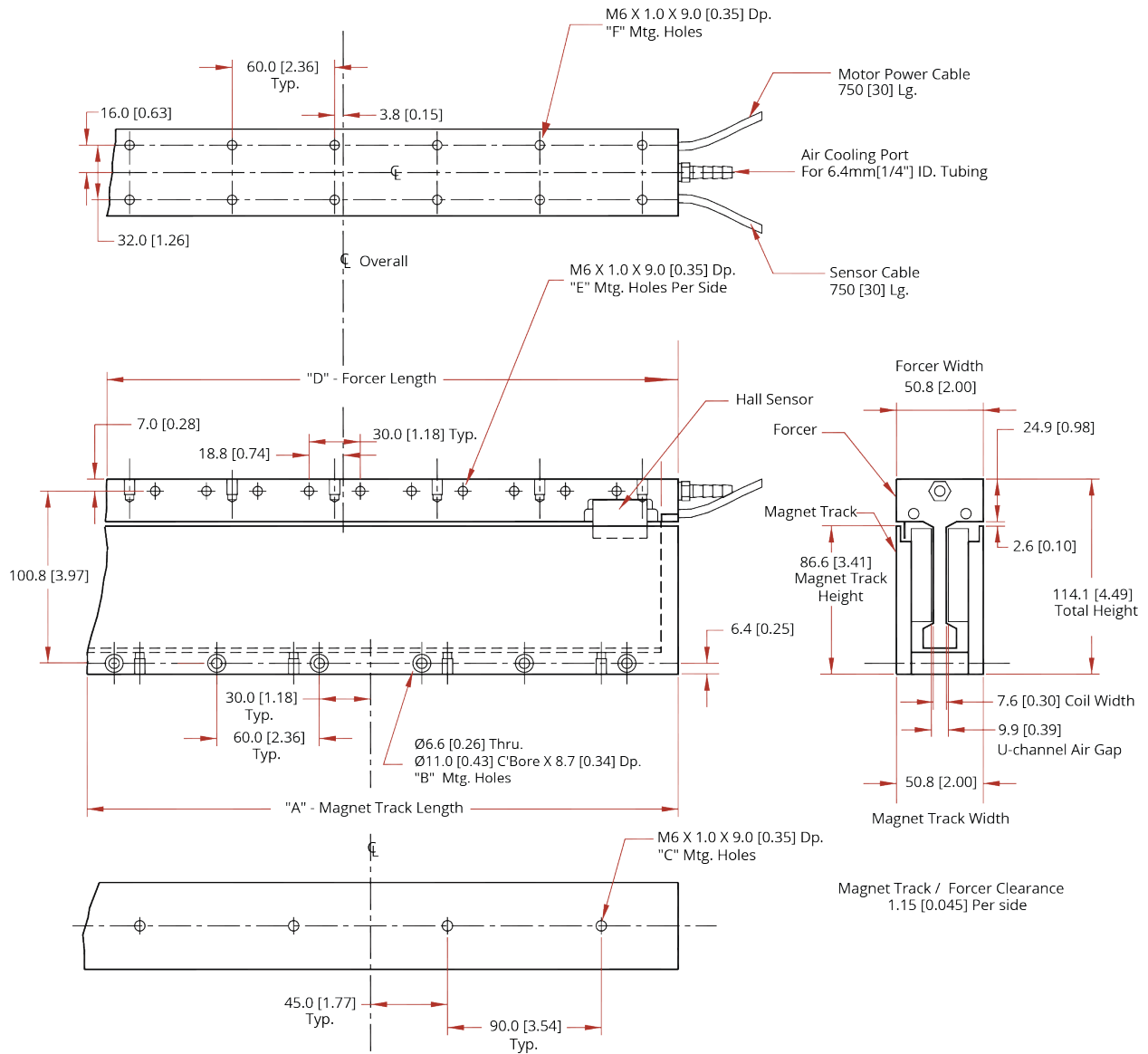

Magnet Track

Model No.	A	B	C
MTH180	180.0 [7.09]	3	2
MTH240	240.0 [9.45]	4	2
MTH300	300.0 [11.81]	5	4
MTH360	360.0 [14.17]	6	4
MTH480	480.0 [18.90]	8	4
MTH600	600.0 [23.63]	10	6
MTH720	720.0 [28.35]	12	8

Forcer

Model No.	D	E	F
BLMH-142	154.5 [6.08]	4	6
BLMH-262	274.5 [10.81]	8	10
BLMH-382	394.5 [15.53]	12	14

Dimensions - millimeters [inches]

Figure 1-6: BLMX Model Dimensions

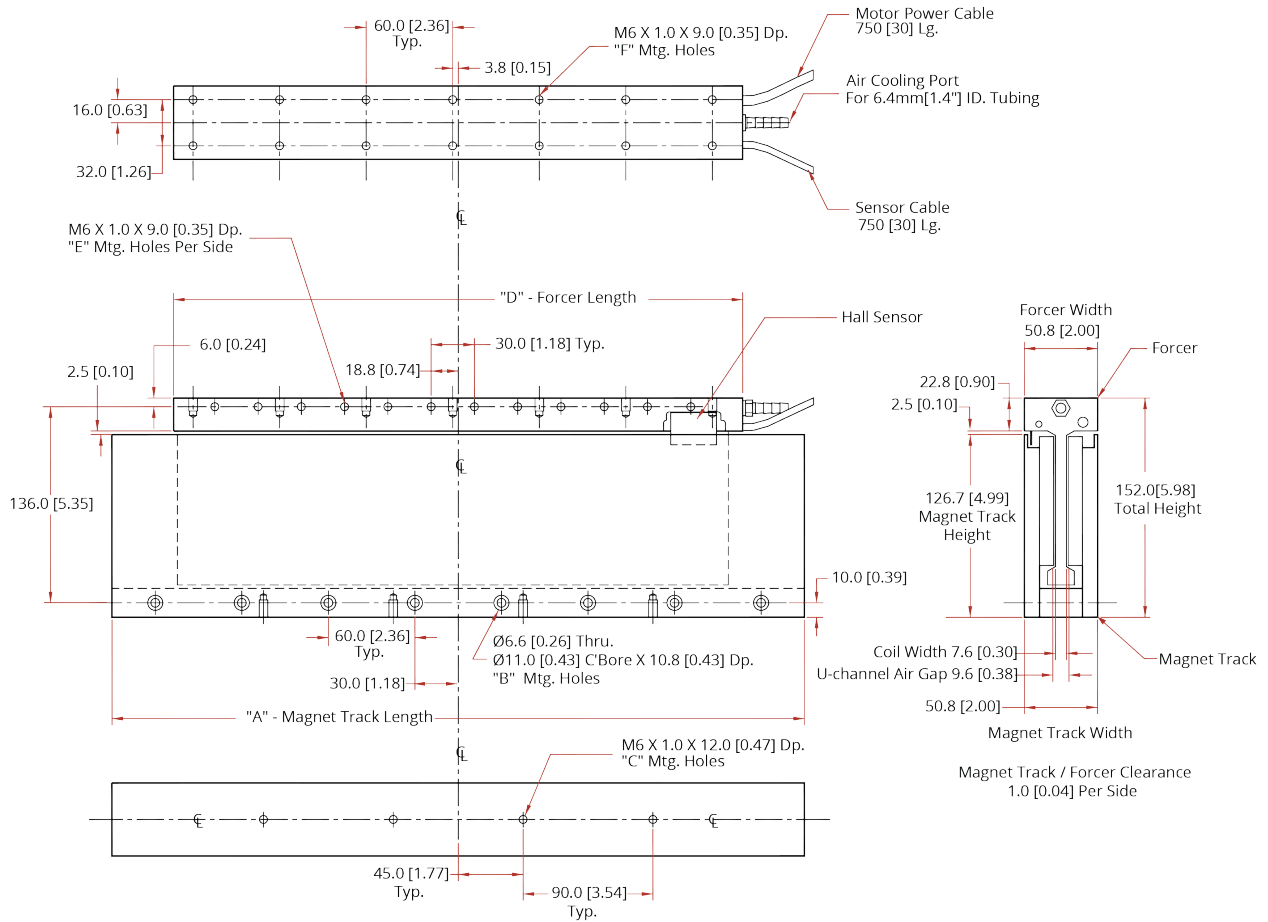

Magnet Track			
Model No.	A	B	C
MTX480	480.0 [18.90]	8	4
MTX600	600.0 [23.63]	10	6
MTX720	720.0 [28.35]	12	8

Forcer			
Model No.	D	E	F
BLMX-382	394.5 [15.53]	12	14
BLMX-502	514.5 [20.26]	16	18

Dimensions - millimeters [inches]

1.3. Environmental Specifications



WARNING: Use this product only in environments and operating conditions that are approved in this manual.

Table 1-18: Environmental Specifications

Ambient Temperature	Operating: 0 °C to 25 °C (32 °F to 77 °F) Contact Aerotech for information regarding your specific application and environment.
	Storage: -10 °C to 85 °C (14 °F to 185 °F) in original shipping packaging
Humidity	Operating: 20% to 60% RH
	Storage: 10% to 70% RH, non-condensing in original packaging.
	Ambient conditions need to be such that condensation on the motor does not occur. The motors are not to be used in wash-down environments.
Altitude	Operating: 0 m to 1,000 m (0 ft to 3,280 ft) above sea level
	Contact Aerotech if your specific application involves use above 1,000 m or below sea level.
Atmosphere	Not to be used in a hydrogen atmosphere.
Use	Indoor use only

1.4. Air Requirements

For the motor to operate correctly, the air supply must meet Aerotech specifications.

Air supplied to the motor should be clean and liquid water should not be present.

- If compressed air is used, it must be filtered to 0.25 microns, dry to 0 ° F dew point, and oil free.
- If nitrogen is used, it must be 99.99% pure and filtered to 0.25 microns.

If the air is unfiltered, particles will clog the internal components of the motor.

1.5. Vacuum Operation

There are two vacuum preparation options:

- Low Vacuum (for use in environments from atmospheric pressure, down to 10^{-3} Torr)
- High Vacuum (for use in environments from 10^{-3} Torr, down to 10^{-6} Torr)

Special preparations include:

- Parts are lubricated with vacuum-compatible lubricants.
- Materials, fasteners, and coatings are selected to be compatible with the specified level of vacuum.
- High-vacuum systems are designed to eliminate trapped volumes.
- Prior to assembly, motor parts are thoroughly cleaned in a clean environment.
- The motor is packaged in a special polyethylene bag.

Vacuum Guidelines

To ensure that the motor will continue to perform well in the vacuum environment, use the guidelines that follow (in addition to standard handling, installation, and lubrication guidelines outlined in this manual).

1. Do not remove the motor from its sealed bag until it is ready to use.
2. Always handle the motor in a clean environment and use powder-free polyethylene gloves to prevent any contaminants from adhering to the surface of the motor.
3. During installation, use cleaned, vented, stainless steel fasteners to secure the motor.
4. Reduced air pressure eliminates significant convective heat transfer. This, coupled with the viscous vacuum-compatible lubricants, could result in excessive motor operating temperatures. Because of this, consider all continuous torque ratings to be **40 to 60% lower** than the value specified for operation in normal atmospheric environment. Reduce motor usage accordingly.
5. We recommend that you use a small quantity of **Braycote® 602EF** grease or a compatible substitute of equal quality lubricant in vacuum applications.
6. To reduce outgassing during the initial pump-down to vacuum pressure, Aerotech recommends that you bake out vacuum systems when you first install them into the vacuum chamber. Bake the vacuum components at 60 °C for 24 to 48 hours to desorb water vapor from surfaces and degas polymers (such as cable insulation).

Chapter 2: Assembly and Installation



WARNING: To prevent injury or damage to the equipment, you will need devices in place that will prevent unexpected motion in the event of an intentional or unintentional disruption of electrical power. Applications with vertical axes require a fail-safe brake.

A linear motor consists of two main components, a forcer and a magnet track. Interaction between the forcer and magnet track produces a force to cause linear motion. The controller, amplifier, and position feedback devices provide for the correct commutation and position of the motor.

The linear motor can be configured in two different ways. The magnet track can be held stationary while the forcer moves or the forcer can be held stationary while the magnet track moves.

Figure 2-1: Motor Assembled in a Linear Stage

The stage tabletop and hardcover have been removed.

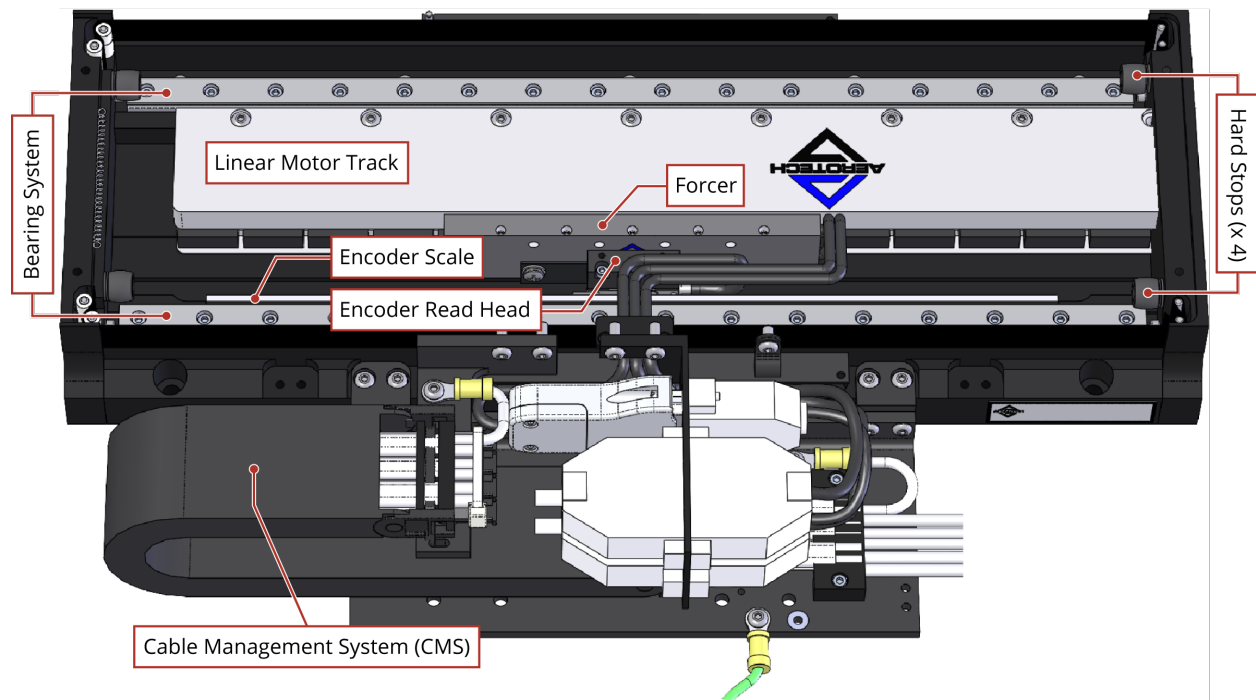

2.1. Bearing System

Like a ball screw carriage, the linear forcer assembly must be supported by a linear bearing system (refer to [Figure 2-1](#)). The linear bearing system must be capable of supporting the load/heat sink and the forcer. The forcer is constructed of non-magnetic materials, and, consequently, the forcer is not attracted to the magnet track.

2.2. Position Transducer Resolution

The motion controller requires a position transducer for all forms of motion control. This is typically a linear encoder. The specific application determines the encoder resolution.

2.3. Cable Management

If the forcer moves in the system, you must use a high-flex cable management system (CMS). If the stage moves and the forcer is stationary, you do not need to use a CMS.

If the forcer motor power and feedback cables are long enough for your travel, they can be used in the CMS.

If the forcer motor power and feedback cables are not long enough for the CMS or if this is a vacuum-prepared system, the cables will need to terminate before they enter the CMS. You will need to terminate the flying leads of the forcer cables at, in most cases, standard D-shell connectors. You should then connect those connectors to the mating connectors of the high-flex cables that will be used in the CMS.

Refer to [Table 2-1](#) for required bend radius for a given high flex cable forcer.

Table 2-1: Bend Radius

Motor	Bend Radius
BLMSC, BLMUC, BLMC, BLM	47 mm [1.9 in]
BLMH	82 mm [3.2 in]
BLMX	114 mm [4.5 in]

2.4. Mechanical Arrangement of the Magnet Track

You can mount the magnet track with the opening up, down, left, or right based on the machine design.

Figure 2-2: Linear Motor Mounting Configurations (end view)

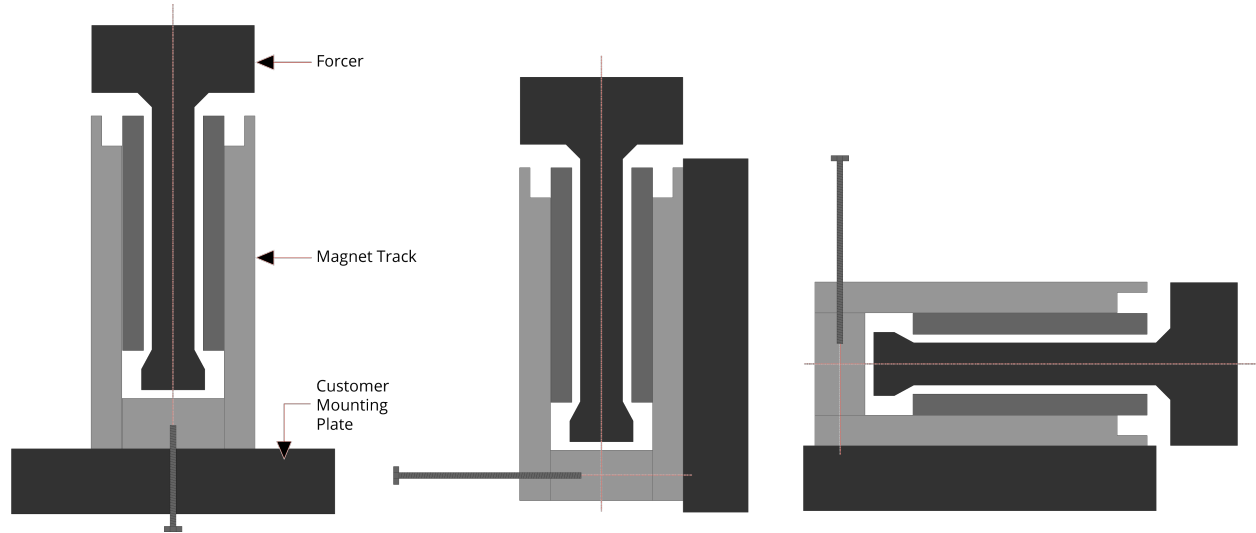

2.5. Track Stacking

Connect the magnet tracks end-to-end to increase the linear motor travel distance. Align the labels as shown.



IMPORTANT: Use a reference edge or alignment fixture and mounting hole pattern (refer to [Section 1.2. Dimensions](#)) to align the tracks. A small gap (up to 0.5 mm [.020"]) between adjacent tracks will not adversely effect forcer performance.

Figure 2-3: Stacking Tracks

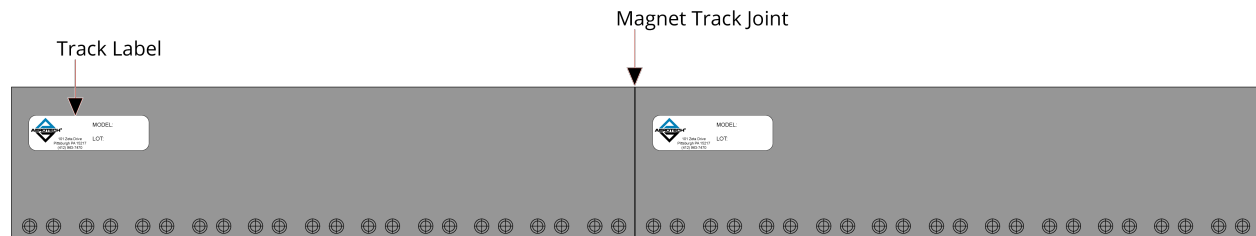

2.6. Straightness and Flatness Tolerance

In order for the linear motor system (forcer and magnet track) to operate correctly, it must be properly aligned to the bearing system travel. This section outlines the maximum permissible deviation the motor can see during motion and still operate properly.

The straightness and flatness tolerances are the deviations from a straight line in two dimensions during travel. There are two separate alignment tolerances: straightness (side-to-side) and flatness (in-and-out).

2.6.1. BLMSC Tolerances

With the forcer aligned as in [Figure 2-4](#), the air gap in the magnet track is 0.76 mm (0.030 in) on either side of the forcer. The straightness can deviate left or right ± 0.38 mm (0.015 in) from the centerline. For example, a deviation can result in an 0.38 mm (0.015 in) air gap on one side and 1.14 mm (0.045 in) on the other side.

The nominal forcer height out of the track is 1.3 mm (0.051 in). The flatness can deviate up an additional 0.25 mm (0.010 in) for a total of 2.26 mm (0.089 in) from the track edge to the forcer edge. The flatness can also deviate down 0.25 mm (0.010 in) for a total of 1.75 mm (0.069 in) from the track edge to the forcer edge.

Figure 2-4: BLMSC Straightness and Flatness Tolerances

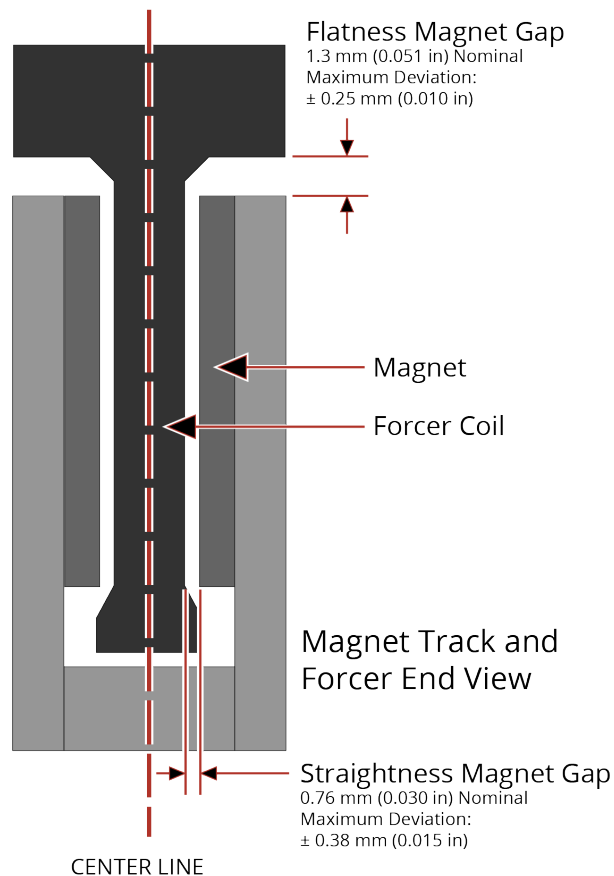

2.6.2. BLMUC Tolerances

With the forcer aligned as in [Figure 2-5](#), the air gap in the magnet track is 0.76 mm (0.030 in) on either side of the forcer. The straightness can deviate left or right ± 0.38 mm (0.015 in) from the centerline. For example, a deviation can result in an 0.38 mm (0.015 in) air gap on one side and 1.14 mm (0.045 in) on the other side.

The nominal forcer height out of the track is 2.0 mm (0.079 in). The flatness can deviate up an additional 0.25 mm (0.010 in) for a total of 2.26 mm (0.089 in) from the track edge to the forcer edge. The flatness can also deviate down 0.25 mm (0.010 in) for a total of 1.75 mm (0.069 in) from the track edge to the forcer edge.

Figure 2-5: BLMUC Straightness and Flatness Tolerances

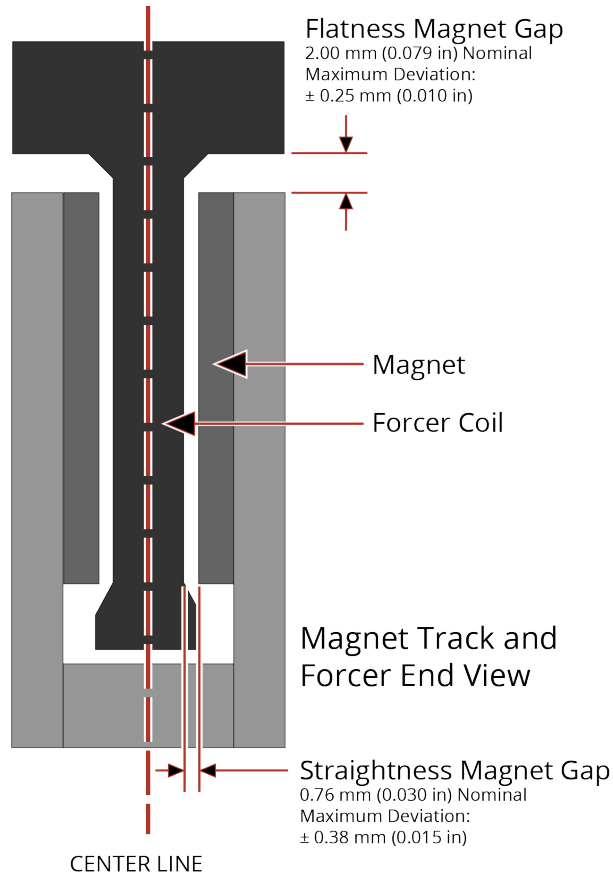

2.6.3. BLMC Tolerances

With the forcer aligned as in [Figure 2-6](#), the air gap in the magnet track is 0.76 mm (0.030 in) on either side of the forcer. The straightness can deviate left or right ± 0.38 mm (0.015 in) from the centerline. For example, a deviation can result in an 0.38 mm (0.015 in) air gap on one side and 1.14 mm (0.045 in) on the other side.

The nominal forcer height out of the track is 1.3 mm (0.050 in). The flatness can deviate up an additional 0.38 mm (0.015 in) for a total of 1.65 mm (0.065 in) from the track edge to the forcer edge. The flatness can also deviate down 0.38 mm (0.015 in) for a total of 0.89 mm (0.035 in) from the track edge to the forcer edge.

Figure 2-6: BLMC Straightness and Flatness Tolerances

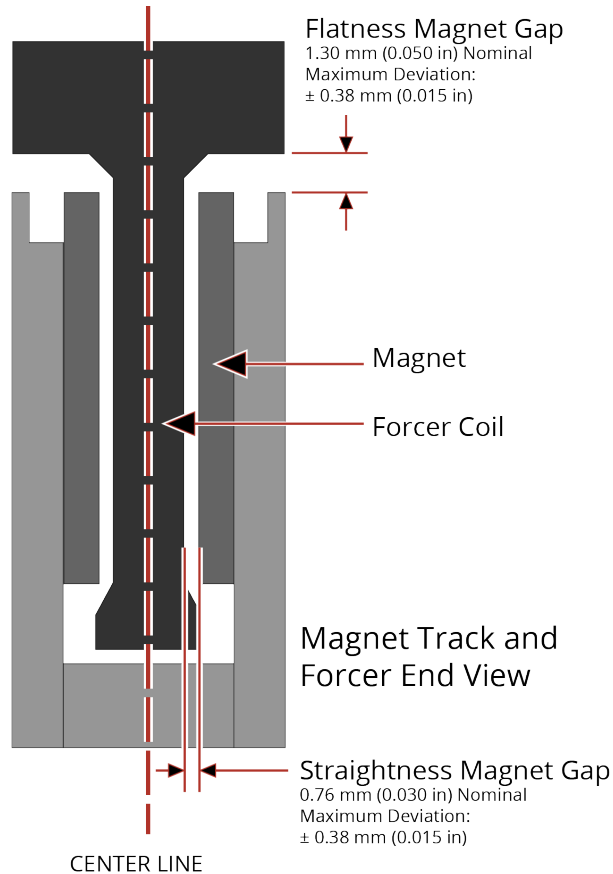

2.6.4. BLM Tolerances

With the forcer aligned as in [Figure 2-7](#), the air gap in the magnet track is 0.025 in (0.64 mm) on either side of the forcer. The straightness can deviate left or right ± 0.25 mm (0.010 in) from the centerline. For example, a deviation can result in an 0.38 mm (0.015 in) air gap on one side and 0.89 mm (0.035 in) on the other side.

The nominal forcer height out of the track is 2.5 mm (0.10 in). The flatness can deviate up an additional 0.51 mm (0.020 in) for a total of 3.05 mm (0.120 in) from the track edge to the forcer edge. The flatness can also deviate down 0.51 mm (0.020 in) for a total of 2.0 mm (0.080 in) from the track edge to the forcer edge.

Figure 2-7: BLM Straightness and Flatness Tolerances

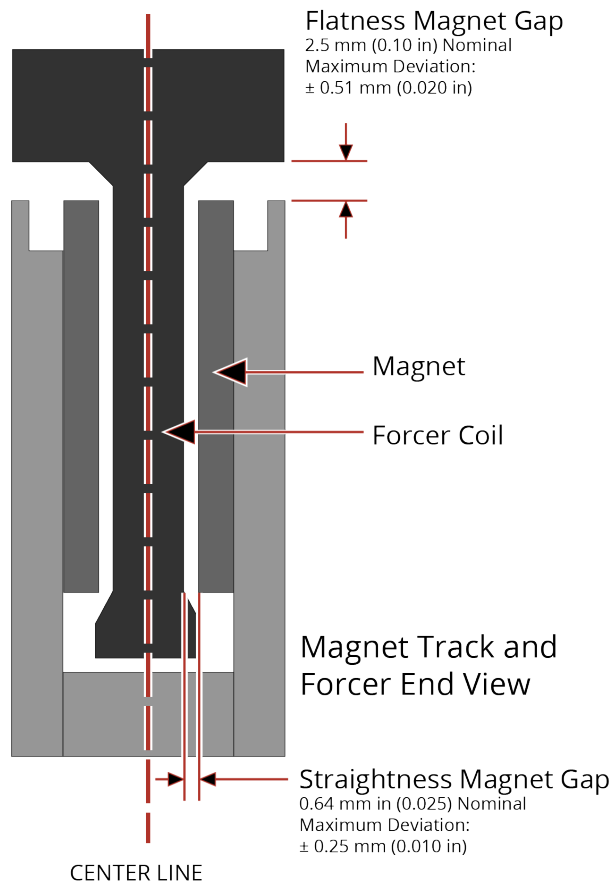

2.6.5. BLMH Tolerances

With the forcer aligned as in [Figure 2-8](#), the air gap in the magnet track is 1.1 mm (0.045 in) on either side of the forcer. The straightness can deviate left or right to ± 0.64 mm (0.025 in) from the centerline. For example, a deviation can result in an 0.51 mm (0.020 in) air gap on one side and 1.79 mm (0.070 in) on the other side.

The nominal forcer height out of the track is 2.5 mm (0.10 in). The flatness can deviate up an additional 0.51 mm (0.020 in) for a total of 3.1 mm (0.120 in) from the track edge to the forcer edge. The flatness can also deviate down 0.020 in (0.51 mm) for a total of 2.0 mm (0.080 in) from the track edge to the forcer edge.

Figure 2-8: BLMH Straightness and Flatness Tolerances

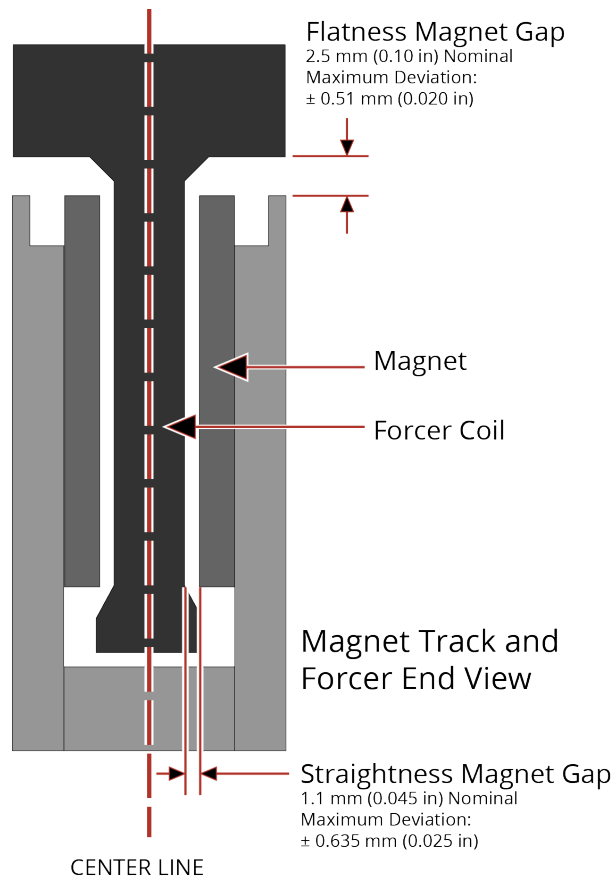

2.6.6. BLMX Tolerances

With the forcer aligned as in [Figure 2-9](#), the air gap in the magnet track is 1.0 mm (0.040 in) on either side of the forcer coil. The straightness can deviate left or right to ± 0.51 mm (0.020 in) from the centerline. For example, a deviation can result in an 0.51 mm (0.020 in) air gap on one side and 1.52 mm (0.060 in) on the other side.

The nominal forcer height out of the track is 2.5 mm (0.10 in). The flatness can deviate up an additional 0.38 mm (0.015 in) for a total of 2.92 mm (0.115 in) from the track edge to the forcer coil. The flatness can also deviate down 0.38 mm (0.015 in) for a total of 2.2 mm (0.085 in) from the track edge to the forcer edge.

Figure 2-9: BLMX Straightness and Flatness Tolerances

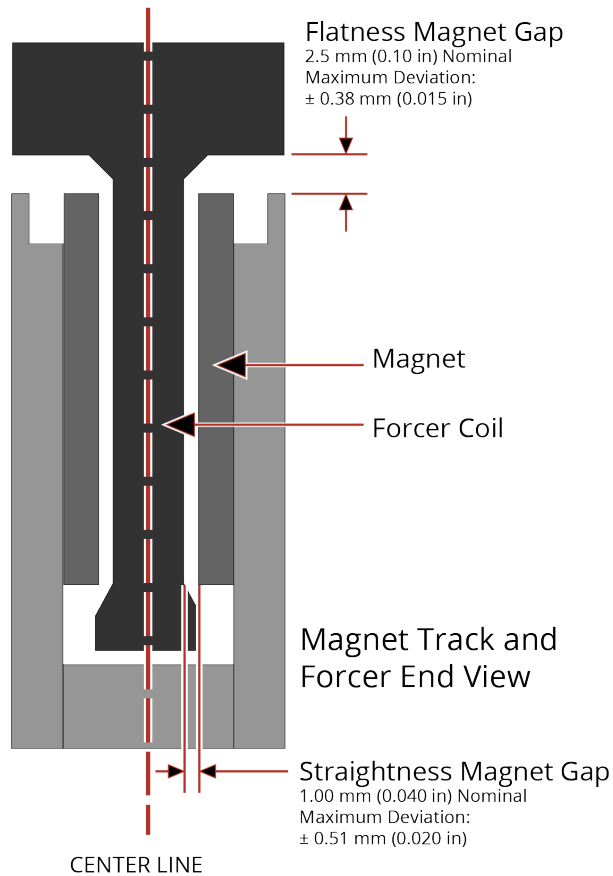

2.7. External Motor Wiring

The forcer is supplied with flying leads for the motor winding, Hall-effect devices, and thermal overload sensor. It is the responsibility of the customer to supply all external wiring to interface with these devices. Customer-supplied wiring must obey all local electrical safety requirements.

- The wiring must be able to supply the rated current without overheating.
- The wire insulation must be rated for the voltage and temperature at which the motor is operating.
- Cable selection and installation should be made to reduce EMI emissions and to increase EMI immunity.

In addition to the external wiring, it is also the responsibility of the customer to provide over-current protection for the motor.

Figure 2-10: Motor Wiring with Flying Leads

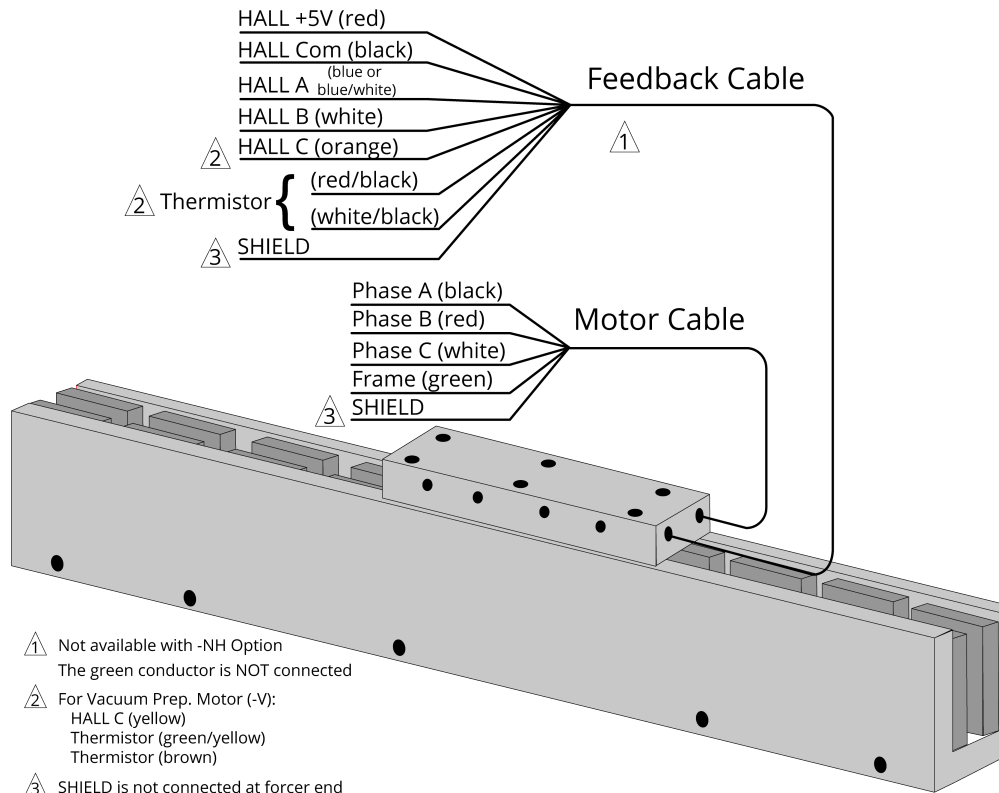

Table 2-2: Cable Diameter and Wire Gauge (Standard)

Motor	Cable	Cable Diameter	Wire Gauge
BLMSC, BLMUC, BLMC, BLM	Motor	4.8 mm (0.189 in)	22 AWG
	Feedback	4.8 mm (0.189 in)	26 AWG
BLMH	Motor	8.2 mm (0.323 in)	16 AWG
	Feedback	4.8 mm (0.189 in)	26 AWG
BLMX	Motor	11.4 mm (0.449 in)	12 AWG
	Feedback	4.8 mm (0.189 in)	26 AWG

Table 2-3: Cable Diameter and Wire Gauge (Vacuum)

Motor	Cable	Cable Diameter	Wire Gauge
BLMUC, BLMC, BLM	Motor	4.32 mm (0.170 in)	22 AWG
	Feedback	4.52 mm (0.178 in)	24 AWG
BLMH	Motor	6.0 mm (0.235 in)	16 AWG
	Feedback	4.52 mm (0.178 in)	24 AWG
BLMX	Motor	10.5 mm (0.412 in)	14 AWG
	Feedback	4.52 mm (0.178 in)	24 AWG

2.7.1. Motor Power Conductors

The motor power conductors must be sized to handle the electrical current requirements of the motor (refer to [Section 1.1. Motor Specifications](#)). Select the wire insulation voltage rating based on the maximum voltage that will be applied to the motor.

2.7.2. Protective Ground

The protective ground is a safety conductor that you must use to ground the motor case. The protective ground conductor must have a current carrying capacity at least equal to the carrying capacity of the motor wires. The standard insulation is "Green/Yellow" and must be rated for the maximum voltage applied to the motor winding. The protective ground wire is typically bundled with the motor wires, but your system could require a separate protective ground wire.

2.7.3. Over-Current Protection

You will need to provide the motor with over-current protection to prevent the motor from overheating. Use programmable current limits, traps, over-current protection circuitry, or fuses. Fuse values should be selected according to the RMS current rating of the motor. For most applications, you should use slow-blow type fuses.

When the motor is part of an Aerotech system that uses an Aerotech controller and drive, use the " A_{pk} " continuous current rating to set the motor over-current protection fault (refer to [Section 1.1](#)). If the motor is not installed in a system configured by Aerotech, you must provide the over-current protection.

2.7.4. Hall-Effect Device and Thermistor Wiring

The insulation of these wires should have a rating for at least the maximum voltage applied to the motor winding. The temperature rating of the wire insulation must also be sufficiently high to withstand the operating temperatures specific to the application.

2.7.5. Wiring Guidelines

The wiring guidelines given below can help to reduce EMI related problems which can result in poor overall system performance.

- Keep cable lengths as short as possible. Long cable runs are more susceptible to EMI pickup than short runs.
- Use grounded shielded cables for both the motor power and signal wiring.
- Use twisted pair shielded cabling to help reduce magnetically induced currents.
- Braided shield has a slightly better low frequency shielding capability than a foil shield. Foil is often used where RF shielding is necessary.
- Do not bundle signal, motor power cables, or AC power lines within the same protective shield or conduit. Use separate protective shields or conduits.
- Do not introduce multiple paths to ground from a grounding point. Multiple paths to ground can create ground loops within the system.
- If necessary, use an EMI suppression device.

2.7.6. Thermal Protective Device

BLM motors use a positive-temperature coefficient (PTC) thermistor as a thermal protection device. The nominal resistance of the thermistor is 100 ohms at 25 °C. The resistance of the thermistor will increase rapidly to 1,000 ohms as the motor temperature increases to the 100 °C transition temperature of the thermistor. The transition temperature is 90 °C for the BLMX motor.



WARNING: The thermal protective device used in the motor must be connected to an external shutdown circuit to provide protection to the motor.

Figure 2-11: Thermal Sensor Resistance as a Function of Temperature

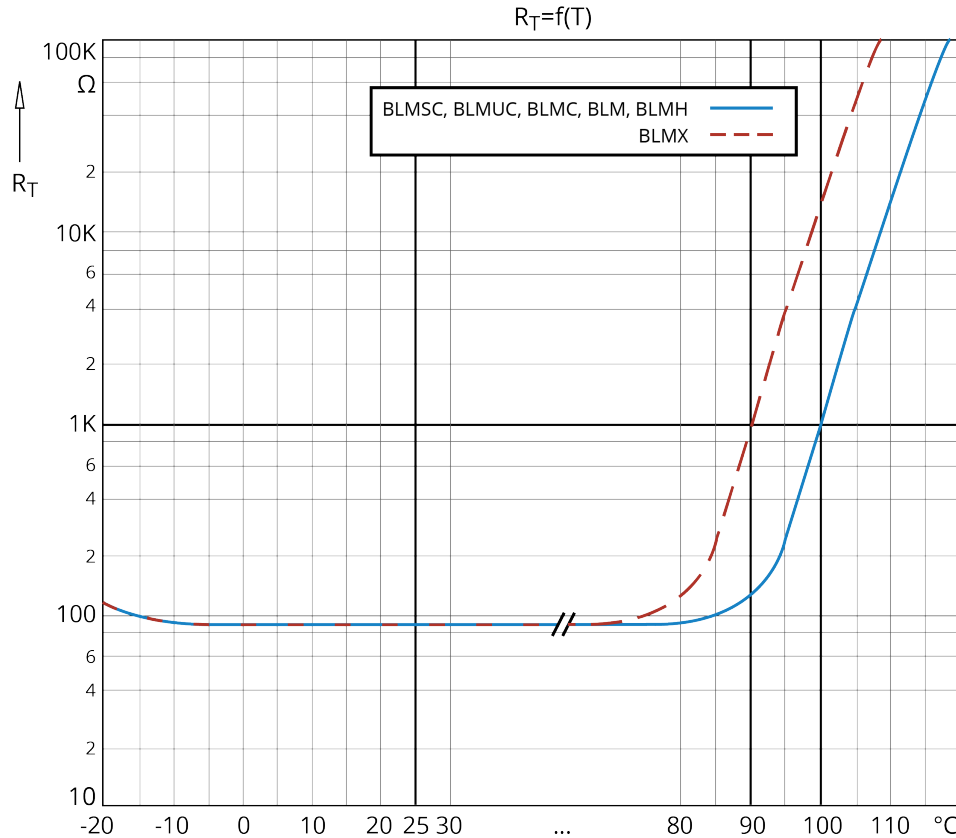



WARNING: If you connect the thermistor to the interface circuit incorrectly, you could cause the thermistor to self-heat. If too much current passes through the thermistor, the temperature will increase and cause the thermistor to activate and increase resistance.

Figure 2-12: Typical Thermistor Interface Circuit

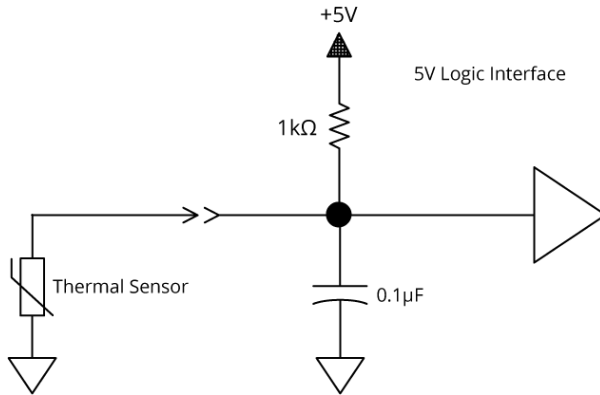

2.8. Hall-Effect Operation and Motor Phasing

In linear servomotors, one popular method of commutation is with Hall-effect sensors. They sense the presence of a magnetic field and provide an output as a function of the forcer position. Aerotech linear motor Hall sensors provide a unique set of Hall-sensor outputs every 60 electrical degrees. Therefore the forcer position can be resolved to any of six segments over 360 electrical degrees. The Hall sensors used in the linear motors have an open collector output. Figure 2-13 shows the motor BEMF versus Hall signal relationship for positive motion.

Figure 2-13: Linear Motor Phasing

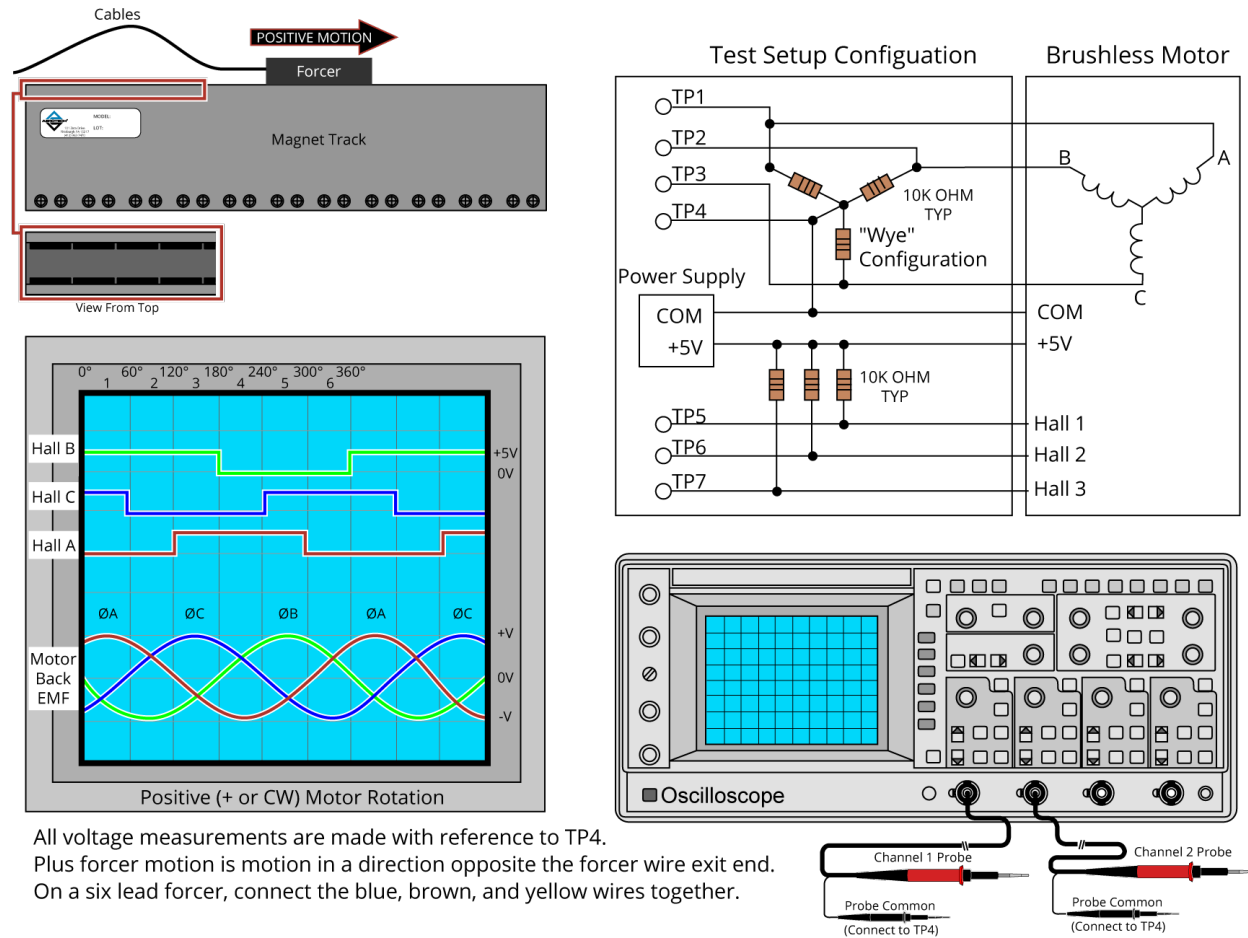

All voltage measurements are made with reference to TP4.
 Plus forcer motion is motion in a direction opposite the forcer wire exit end.
 On a six lead forcer, connect the blue, brown, and yellow wires together.

2.9. Motor Heating

The amount of current that can pass through the motor winding is limited by a rise in temperature above ambient. If the temperature of the motor exceeds the thermal limit, the thermistor sensor will send a signal to the controller and the controller will stop the motor.

The motor specifications show the continuous motor current that will result in a predetermined temperature rise of the motor. The motor specifications listed in [Section 1.1.](#) were compiled under a single set of operating conditions and environmental specifications ([Section 1.3.](#)).

The operating conditions of the motor are defined by:

- The thermal characteristics of the motor.
- The effectiveness of the medium that surrounds the motor to transfer heat away from the motor.
- The use of supplemental cooling.

Examples of what could cause the motor to overheat:

- Poor heat transfer away from the motor.
- The load is too high for the motor.
- The ambient temperature has increased above the expected operating conditions.

This page intentionally left blank.

Chapter 3: Maintenance



DANGER: To minimize the possibility of bodily injury or death, disconnect all electrical power before you do maintenance or make adjustments to the equipment.



DANGER: Strong Magnets / Electromagnetic Fields

- Interaction with metallic objects could produce pinch dangers.
- Use non-magnetic tools when you do service to the motor.
- Do not attempt to disassemble the magnet track.

Inspect the BLM motor at least once per month. You will have to determine a longer or shorter inspection interval based on the application and conditions, such as the duty cycle, speed, and environment.

Visually inspect the motor and cables to make sure that:

- the motor does not become too hot.
- the motor does not vibrate too much.
- the air flow to the motor is not blocked.
- you do not see evidence of burns or smell smoke.

You will also need to

- tighten loose motor-to-machine hardware.
- remove an accumulation of debris on the motor.
- replace or repair damaged cables.
- clean the motor and any components and cables if needed.
- assess any damage to the motor.

Cleaning

Motors should be wiped with a clean dry cloth to remove any grease, dirt, or other material that has accumulated on the motor. Do not use fluids and sprays so that you do not contaminate the internal parts of the motor. Be careful when you clean the motor so that you do not remove the text on the motor labels.

Lubrication

Aerotech U-Channel linear motors do not require lubrication. It is the responsibility of the customer or OEM to lubricate customer-supplied components.

Repairs

In general, it is not possible for field service personnel to repair and/or replace damaged or components that have malfunctioned. Repair typically requires that you return the unit to the factory.

Contact Aerotech Global Technical Support for more information.

This page intentionally left blank.

Appendix A: Warranty and Field Service

Aerotech, Inc. warrants its products to be free from harmful defects caused by faulty materials or poor workmanship for a minimum period of one year from date of shipment from Aerotech. Aerotech's liability is limited to replacing, repairing or issuing credit, at its option, for any products that are returned by the original purchaser during the warranty period. Aerotech makes no warranty that its products are fit for the use or purpose to which they may be put by the buyer, whether or not such use or purpose has been disclosed to Aerotech in specifications or drawings previously or subsequently provided, or whether or not Aerotech's products are specifically designed and/or manufactured for buyer's use or purpose. Aerotech's liability on any claim for loss or damage arising out of the sale, resale, or use of any of its products shall in no event exceed the selling price of the unit.

THE EXPRESS WARRANTY SET FORTH HEREIN IS IN LIEU OF AND EXCLUDES ALL OTHER WARRANTIES, EXPRESSED OR IMPLIED, BY OPERATION OF LAW OR OTHERWISE. IN NO EVENT SHALL AEROTECH BE LIABLE FOR CONSEQUENTIAL OR SPECIAL DAMAGES.

Return Products Procedure

Claims for shipment damage (evident or concealed) must be filed with the carrier by the buyer. Aerotech must be notified within thirty (30) days of shipment of incorrect material. No product may be returned, whether in warranty or out of warranty, without first obtaining approval from Aerotech. No credit will be given nor repairs made for products returned without such approval. A "Return Materials Authorization (RMA)" number must accompany any returned product(s). The RMA number may be obtained by calling an Aerotech service center or by submitting the appropriate request available on our website (www.aerotech.com). Products must be returned, prepaid, to an Aerotech service center (no C.O.D. or Collect Freight accepted). The status of any product returned later than thirty (30) days after the issuance of a return authorization number will be subject to review.

Visit [Global Technical Support Portal](#) for the location of your nearest Aerotech Service center.

Returned Product Warranty Determination

After Aerotech's examination, warranty or out-of-warranty status will be determined. If upon Aerotech's examination a warranted defect exists, then the product(s) will be repaired at no charge and shipped, prepaid, back to the buyer. If the buyer desires an expedited method of return, the product(s) will be shipped collect. Warranty repairs do not extend the original warranty period.

Fixed Fee Repairs - Products having fixed-fee pricing will require a valid purchase order or credit card particulars before any service work can begin.

All Other Repairs - After Aerotech's evaluation, the buyer shall be notified of the repair cost. At such time the buyer must issue a valid purchase order to cover the cost of the repair and freight, or authorize the product(s) to be shipped back as is, at the buyer's expense. Failure to obtain a purchase order number or approval within thirty (30) days of notification will result in the product(s) being returned as is, at the buyer's expense.

Repair work is warranted for ninety (90) days from date of shipment. Replacement components are warranted for one year from date of shipment.

Rush Service

At times, the buyer may desire to expedite a repair. Regardless of warranty or out-of-warranty status, the buyer must issue a valid purchase order to cover the added rush service cost. Rush service is subject to Aerotech's approval.

On-site Warranty Repair

If an Aerotech product cannot be made functional by telephone assistance or by sending and having the customer install replacement parts, and cannot be returned to the Aerotech service center for repair, and if Aerotech determines the problem could be warranty-related, then the following policy applies:

Aerotech will provide an on-site Field Service Representative in a reasonable amount of time, provided that the customer issues a valid purchase order to Aerotech covering all transportation and subsistence costs. For warranty field repairs, the customer will not be charged for the cost of labor and material. If service is rendered at times other than normal work periods, then special rates apply.

If during the on-site repair it is determined the problem is not warranty related, then the terms and conditions stated in the following "On-Site Non-Warranty Repair" section apply.

On-site Non-Warranty Repair

If any Aerotech product cannot be made functional by telephone assistance or purchased replacement parts, and cannot be returned to the Aerotech service center for repair, then the following field service policy applies:

Aerotech will provide an on-site Field Service Representative in a reasonable amount of time, provided that the customer issues a valid purchase order to Aerotech covering all transportation and subsistence costs and the prevailing labor cost, including travel time, necessary to complete the repair.

Service Locations

<https://www.aerotech.com/contact-sales.aspx?mapState=showMap>

USA, CANADA, MEXICO

Aerotech, Inc.
Global Headquarters

CHINA

Aerotech China
Full-Service Subsidiary

GERMANY

Aerotech Germany
Full-Service Subsidiary

TAIWAN

Aerotech Taiwan
Full-Service Subsidiary

UNITED KINGDOM

Aerotech United Kingdom
Full-Service Subsidiary

Appendix B: Revision History

Revision	Description
3.02	General Update
3.01	<ul style="list-style-type: none"> • EU Declaration of Conformity updated. • Dimensions updated
3.00	<ul style="list-style-type: none"> • EU Declaration of Conformity updated. • UK Declaration of Conformity added. • Safety Procedures and Warnings updated. • Ordering options updated • Specifications updated • Dimensions updated
2.08	Revision changes have been archived. If you need a copy of this revision, contact AerotechGlobal Technical Support.
2.07	
2.06	
2.05	
2.04	
2.03	
2.02	
2.01	
2.00	
1.08	
1.07	
1.06	
1.05	
1.04	
1.03a	
1.02	
1.02	
1.01a	

This page intentionally left blank.

Index

	#			
2014/35/EU		6		
	A			
Agency Approvals		8		
Altitude		40		
Ambient Temperature		40		
Atmosphere		40		
	B			
Bend Radius		44		
BLM				
Cooling Options		20		
Dimensions		37		
Forcer Options		20		
Hall Options		20		
Motor Specifications (P Magnet Track)		28-29		
Motor Specifications (S Magnet Track)		30-31		
Vacuum Options		20		
Winding Options		20		
BLMC				
Cooling Options		19		
Dimensions		36		
Forcer Options		19		
Hall Options		19		
Motor Specifications (P Magnet Track)		26		
Motor Specifications (S Magnet Track)		27		
Vacuum Options		19		
Winding Options		19		
BLMH				
Cooling Options		21		
Dimensions		38		
Forcer Options		21		
Hall Options		21		
Motor Specifications (P Magnet Track)		32		
Vacuum Options		21		
Winding Options		21		
BLMSC				
Cooling Options		17		
Dimensions		34		
Forcer Options		17		
			Hall Options	17
			Motor Specifications	23
			Vacuum Options	17
			BLMUC	
			Cooling Options	18
			Dimensions	35
			Forcer Options	18
			Hall Options	18
			Vacuum Options	18
			Winding Options	18
			BLMX	
			Cooling Options	22
			Dimensions	39
			Forcer Options	22
			Hall Options	22
			Motor Specifications	33
			Vacuum Options	22
			Winding Options	22
			BLUMC	
			Motor Specifications (P Magnet Track)	24
			Motor Specifications (S Magnet Track)	25
			Braycote® 602EF	42
			C	
			Cable Diameter (standard)	52
			Cable Diameter (vacuum)	53
			clean	59
			D	
			Declaration of Conformity (EU)	6
			Declaration of Conformity (UKCA)	7
			E	
			Electrical Warnings	11
			Encoder Scale example	43
			EU 2015/863	6
			EU Declaration of Conformity	6
			F	
			Flying Leads	52
			G	
			grease	42

		Thermistor Interface Circuit	55
		transducer	44
	H		
Handling			15
Humidity			40
		U	
		UKCA Declaration of Conformity	7
	I		
Indoor use only			40
		V	
		vacuum cable diameter	53
	L	vacuum guidelines	42
label		vacuum lubricant (Braycote 602EF)	42
Linear Motor Mounting Configurations		vacuum wire gauge	53
lubricant			
vacuum			42
		W	
		Warnings	9
	M	Warranty and Field Service	61
Motor Power Conductors		Wire Gauge (standard)	52
Motor Specifications		Wire Gauge (vacuum)	53
Motor-Related Warnings		Wiring Guidelines	53
	P		
packing list			15
part number			15
Protective Ground			53
	R		
repair			59
Revision History			63
	S		
serial number			15
Specifications			23
stabilizing stage			16
Stacking Tracks			45
stage			
stabilizing			16
standard cable diameter			52
standard wire gauge			52
Storage			15
	T		
Table of Contents			3
Thermal Protective Device			54