



CCS130DR Mechanical-Bearing Direct-Drive Rotary Collet Stage

HARDWARE MANUAL

Revision 2.00



GLOBAL TECHNICAL SUPPORT

Go to the [Global Technical Support Portal](#) for information and support about your Aerotech, Inc. products. The website supplies software, product manuals, Help files, training schedules, and PC-to-PC remote technical support. If necessary, you can complete Product Return (RMA) forms and get information about repairs and spare or replacement parts. To get help immediately, contact a service office or your sales representative. Include your customer order number in your email or have it available before you call.

This manual contains proprietary information and may not be reproduced, disclosed, or used in whole or in part without the express written permission of Aerotech, Inc. Product names mentioned herein are used for identification purposes only and may be trademarks of their respective companies.

Copyright © 2014-2024, Aerotech, Inc., All rights reserved.



Table of Contents

CCS130DR Mechanical-Bearing Direct-Drive Rotary Collet Stage	1
Table of Contents	3
List of Figures	4
List of Tables	5
EU Declaration of Incorporation	6
UKCA Declaration of Incorporation	7
Safety Procedures and Warnings	8
Installation and Operation	9
Electrical Warnings	10
Motor-Related Warnings	11
Pinch Points	12
Handling and Storage	13
Chapter 1: Overview	15
1.1. Environmental Specifications	16
1.2. Accuracy and Temperature Effects	16
1.3. Basic Specifications	17
Chapter 2: Installation	19
2.1. Dimensions	19
2.2. Securing the Stage to the Mounting Surface	20
2.3. Load Capability	22
2.4. Air Requirements	23
2.5. Wet Cut Fluid Requirements	23
2.6. Mechanical Setup	24
2.7. Changing the Workholding Devices	25
Chapter 3: Electrical Installation	27
3.1. Motor and Feedback Connectors	28
3.2. Motor and Feedback Wiring	30
3.3. Motor and Feedback Specifications	31
3.4. Limits, Marker, and Machine Direction	33
3.5. Motor and Feedback Phasing	34
Chapter 4: Maintenance	37
4.1. Service and Inspection Schedule	38
4.2. Cleaning and Lubrication	39
4.3. Collet & Collet Chuck Lubrication and Cleaning	40
4.4. Seal Replacement	41
4.4.1. Piston Seal Change Procedure	41
4.4.2. Ringseal O-Ring Replacement (-WCUT option only)	42
4.4.3. Wet Cut Rotary Union Seal Replacement (-WCUT option only)	43
4.5. Wet Cut Rotary Union Removal	46
4.6. Troubleshooting	48
Appendix A: Warranty and Field Service	49
Appendix B: Revision History	51
Index	53

List of Figures

Figure 1-1: Standard Features	15
Figure 2-1: CCS130DR Dimensions	19
Figure 2-2: Stage Mounting Holes	21
Figure 2-3: CCS130DR-160 Wet Cut Rotary Union Location	22
Figure 2-4: Collet Installation	26
Figure 3-1: CCS130DR Motor and Feedback Wiring	30
Figure 3-2: Machine Direction	33
Figure 3-3: Hall Phasing Diagram	34
Figure 3-4: Encoder Phasing Reference Diagram (Analog/Sine Wave)	35
Figure 4-1: Collet and Collet Chuck Tapered Surfaces	40
Figure 4-2: Ringseal Removal	42
Figure 4-3: Cross-section View of Ringseal Showing O-Rings	42
Figure 4-4: Cross-Section View of Wet Cut Rotary Union	43
Figure 4-5: Rear Carriage Cover w/ Wet Cut Rotary Union	44
Figure 4-6: Seal Location	44
Figure 4-7: Wet Cut Rotary Union Shaft Inspection	45
Figure 4-8: Wet Cut Rotary Union	46
Figure 4-9: Housing Assembly Showing Rotary Union	46
Figure 4-10: Rotary Union Removal	47

List of Tables

Table 1-1: Model Numbers and Ordering Options	15
Table 1-2: Environmental Specifications	16
Table 1-3: CCS130DR Series Specifications	17
Table 2-1: Stage Mounting Surface Flatness Requirement	20
Table 2-2: Stage to Mounting Surface Hardware	21
Table 3-1: Brushless Motor Connector Pinout	28
Table 3-2: Mating Connector Part Numbers for D-Style Motor Connectors	28
Table 3-3: Feedback Connector Pinout	29
Table 3-4: Mating Connector Part Numbers for D-Style Feedback Connectors	29
Table 3-5: Hall-Effect Sensor Specifications	31
Table 3-6: Thermistor Specifications	31
Table 3-7: Encoder Specifications	31
Table 3-8: Motor Specifications	32
Table 4-1: Recommended Lubricants	39
Table 4-2: Troubleshooting	48

EU Declaration of Incorporation

Manufacturer Aerotech, Inc.
101 Zeta Drive
Pittsburgh, PA 15238-2811
USA



herewith declares that the product:

CCS130DR stage

is intended to be incorporated into machinery to constitute machinery covered by the Directive 2006/42/EC as amended; and that the following harmonized European standards have been applied:

EN ISO 12100:2010

Safety of Machinery - Basic concepts, general principles for design

EN 60204-1:2010

Safety of Machinery - Electrical equipment of machines - Part 1: General requirements

and further more declares that

it is not allowed to put the equipment into service until the machinery into which it is to be incorporated or of which it is to be a component has been found and declared to be in conformity with the provisions of the Directive 2006/42/EC and with national implementing legislation, for example, as a whole, including the equipment referred to in this Declaration.

This is to certify that the aforementioned product is in accordance with the applicable requirements of the following directive(s):

EU 2015/863

Directive, Restricted Substances (RoHS 3)

Authorized Representative:

/ Jochen Jäger

Operations Manager
Aerotech GmbH
Gustav-Weißkopf-Str. 18
90768 Fürth
Germany

Engineer Verifying Compliance

/ Alex Weibel

Aerotech, Inc.
101 Zeta Drive
Pittsburgh, PA 15238-2811
USA
8/28/2024

Date

UKCA Declaration of Incorporation

Manufacturer
Aerotech, Inc.
101 Zeta Drive
Pittsburgh, PA 15238-2811
USA



herewith declares that the product:

CCS130DR stage

To which this declaration relates, meets the essential health and safety requirements and is in conformity with the relevant UK Legislation listed below:

Supply of Machinery (Safety) Regulations 2008

Hazardous Substances in Electrical and Electronic Equipment Regulations 2012

Using the relevant section of the following UK Designated Standards and other normative documents when installed in accordance with the installation instructions supplied by the manufacturer.

EN ISO 12100:2010

Safety of Machinery - Basic concepts, general principles for design

EN 60204-1:2010

Safety of Machinery - Electrical equipment of machines - Part 1: General requirements

and furthermore declares that it is not allowed to put the product into service until the machinery into which it is to be incorporated or of which it is to be a component has been found and declared to be in conformity with the provisions of the Supply of Machinery (Safety) Regulations 2008 UK Legislation and with national implementing legislation, for example, as a whole, including the equipment referred to in this Declaration.

**Authorized
Representative:**

A handwritten signature in black ink, appearing to read 'Simon Smith'.

/ Simon Smith

Managing Director
Aerotech Ltd
The Old Brick Kiln, Ramsdell, Tadley
Hampshire RG26 5PR
UK

**Engineer Verifying
Compliance**

A handwritten signature in black ink, appearing to read 'Alex Weibel'.

/ Alex Weibel

Aerotech, Inc.
101 Zeta Drive
Pittsburgh, PA 15238-2811
USA
8/28/2024

Date

Safety Procedures and Warnings



IMPORTANT: This manual tells you how to carefully and correctly use and operate the stage.

- Read all parts of this manual before you install or operate the stage or before you do maintenance to your system.
- To prevent injury to you and damage to the equipment, obey the precautions in this manual.
- All specifications and illustrations are for reference only and were complete and accurate as of the release of this manual. To find the newest information about this product, refer to www.aerotech.com.

If you do not understand the information in this manual, contact Aerotech Global Technical Support.



IMPORTANT: This product has been designed for light industrial manufacturing or laboratory environments. If the product is used in a manner not specified by the manufacturer:

- The protection provided by the equipment could be impaired.
- The life expectancy of the product could be decreased.

Safety notes and symbols are placed throughout this manual to warn you of the potential risks at the moment of the safety note or if you fail to obey the safety note.



Shock/Electrocution Hazard



Pinch, Shear, or Crush Hazard



General/Conditional Awareness



Rotational Machinery Hazard



Hot Surface Hazard



Pinch/Entanglement Hazard



Magnetic Field Hazard



Trip Hazard



Heavy, Bulky Lifting Hazard



Appropriate Equipment Required



Pressure/Explosive Atmosphere Hazard



Electrostatic Discharge Hazard

A blue circle symbol is an action or tip that you should obey. Some examples include:



General tip



Read the manual/section



Wear personal protective equipment (PPE): Safety Glasses



If applicable, do not lift unassisted



Wear personal protective equipment (PPE): Gloves



Wear personal protective equipment (PPE): Hearing Protection

Installation and Operation

To decrease the risk of damage to the equipment, you must obey the precautions that follow.



DANGER: General Hazard Warning!

This product can produce high forces and move at velocities that could cause injury. The user is responsible for its safe operation. The following general equation is provided to assist with risk assessments in regards to contact and pinch points:

$$Pressure_{Max} \left[\frac{N}{mm^2} \right] = \frac{Force_{Peak} [N]}{Area_{Contact} [mm^2]}$$



WARNING: General Hazard Warning!

- Only trained operators should operate this equipment.
- All service and maintenance must be done by approved personnel.
- Use this product only in environments and operating conditions that are approved in this manual.
- Never install or operate equipment that appears to be damaged.
- Make sure that the product is securely mounted before you operate it.
- Use care when you move the stage or you could negatively affect the performance of it.



WARNING: Trip Hazard!

Route, house, and secure all cables, duct work, air, or water lines. Failure to do so could introduce trip hazards around the system that could result in physical injury or could damage the equipment.

Electrical Warnings

To decrease the risk of electrical shock, injury, death, and damage to the equipment, obey the precautions that follow.



DANGER: Electrical Shock Hazard!

- Stage motor phase voltage levels could be hazardous live.
- Personnel are protected from hazardous voltages unless electrical interconnections, protective bonding (safety ground), or motor/stage enclosures are compromised.
- Do not connect or disconnect stage/motor interconnections while connected to a live electrical power source.
- Before you set up or do maintenance, disconnect electrical power.
- It is the responsibility of the End User/System Integrator to make sure that stages are properly connected and grounded per Engineering Standards and applicable safety requirements.
- It is the responsibility of the End User/System Integrator to configure the system drive or controller within the Aerotech motor/stage electrical and mechanical specifications.

Motor-Related Warnings

Aerotech motors are capable of producing high forces and velocities. Obey all warnings and all applicable codes and standards when you use or operate a stage or system that incorporates Aerotech motors.



DANGER: Mechanical Hazard!

Personnel must be made aware of the mechanical hazards during set up or when you do service to the stage.



Stage movement could create pinch points, entanglement hazards, or rotational mechanical hazards.



DANGER: Hot Surface Hazard!

- The stage/motor frame temperature could exceed 70°C in some applications.
- Do not touch the stage/motor frame while it is in operation.
- Wait until the stage/motor has cooled before you touch it.



DANGER: Risk in Explosive Atmosphere!

- Standard Aerotech stage/motors are not rated for applications with explosive atmospheres such as airborne dust or combustible vapors.
- Do not operate stage/motors outside of Aerotech environmental specifications.



DANGER: Magnetic Field Hazard!

Aerotech stage/motors contain magnets which can present a Magnetic Field Hazard.

- Do not disassemble a stage motor under any circumstances.
- Strong magnetic fields could interfere with external/internal medical devices.
- Strong magnetic fields could present mechanical hazards such as pinch points.

Pinch Points

A pinch point is a mechanical hazard that can occur when there are exposed parts of the stage or system that can move. For example, the travel of a stage tabletop could expose the user to a pinch point between the tabletop and the stage housing. The images that follow will show you typical external and internal pinch point locations.

DANGER: Mechanical Hazard!



- System travel can cause crush, shear, or pinch injuries.
- Only trained operators should operate this equipment.
- Do not put yourself in the travel path of machinery.
- Restrict access to all motor and stage parts
 - when the system moves under power (during normal operation, for example).
 - when the system is moved manually (during the installation process or when you do maintenance, for example).
- Motors are capable of very high speeds and acceleration rates.

Figure 1: Typical Pinch Point Locations



DANGER: Rotating Machinery Hazard!

Keep hands and loose objects away from the stage while it is in motion.



DANGER: Pinch Hazard!

Keep hands and loose objects away from the collet if it is installed.

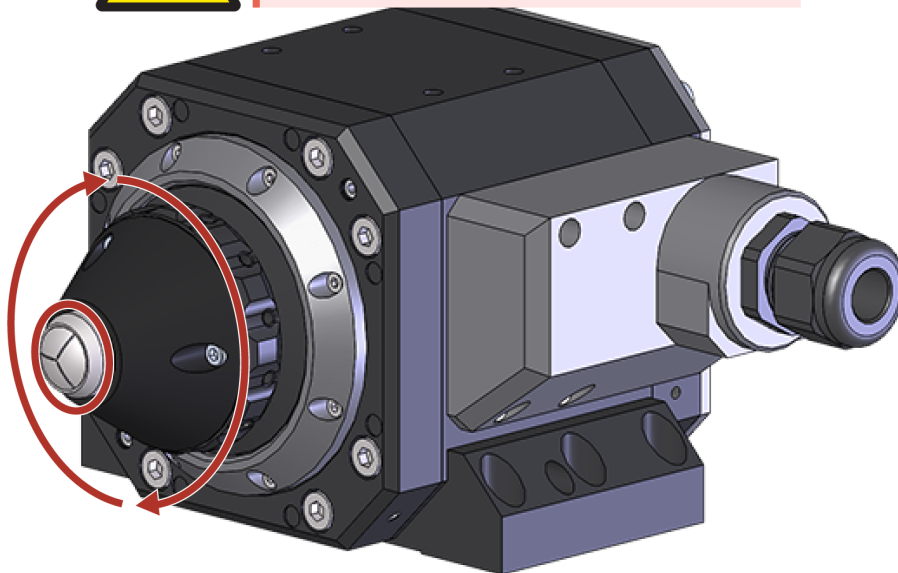

Handling and Storage



IMPORTANT: It is the responsibility of the customer to safely and carefully lift and move the stage.

- Be careful when you move or transport the stage.
- Retain the shipping materials for future use.
- Transport or store the stage in its protective packaging.



WARNING: Electrostatic Discharge (ESD) Sensitive Components!

Wear an ESD wrist strap when you handle, install, or do service to the system assembly.

You could damage the power supply or drives if you fail to observe the correct ESD practices.

Inspect the shipping container for any evidence of shipping damage. If any damage exists, notify the shipping carrier immediately.

Remove the packing list from the shipping container. Make sure that all the items specified on the packing list are contained within the package.

The documentation for the stage is on the included installation device. The documents include manuals, interconnection drawings, and other documentation pertaining to the system. Save this information for future reference.

Each stage has a label listing the system part number and serial number. These numbers contain information necessary for maintenance or system hardware and software updates. Locate this label and record the information for later reference.

Unpacking and Handling

It is the responsibility of the customer to safely and carefully lift and move the stage.



IMPORTANT: All electronic equipment and instrumentation is wrapped in antistatic material and packaged with desiccant. Ensure that the antistatic material is not damaged during unpacking.



DANGER: Lifting Hazard! Use care when you move the stage or you could negatively affect the performance of it.

- Use the correct lifting techniques, mechanical assistance, or additional help to lift or move this product.
- Do not use the cables or the connectors to lift or move this product.
- Make sure that all moving parts are secure before you move the stage. Unsecured moving parts could shift and cause injury or damage to the equipment.
- If the stage is heavy, a single person lift could cause injury. Use assistance when you lift or move it.
 - Refer to [Section 2.1. Dimensions](#) for dimensions
 - Refer to [Section 1.3. Basic Specifications](#) for weight specifications.

Carefully remove the stage from its protective shipping container.

- Lift this product only by the base.
- For multi-axis assemblies, always lift the system by the lower axis.
- Use a cart, dolly, or similar device to move the stage to a new location.

Gently set the stage on a smooth, flat, and clean surface. Use compressed nitrogen or clean, dry, oil-free air to remove any dust or debris that has collected during shipping.

Before you operate the stage, let it stabilize at room temperature for at least 12 hours. This will ensure that all of the alignments, preloads, and tolerances are the same as they were when they were tested at Aerotech.

Storage

Store the stage in the original shipping container. If the original packaging included ESD protective packaging, make sure to store the stage in it. The storage location must be dry, free of dust, free of vibrations, and flat.

Chapter 1: Overview

Table 1-1: Model Numbers and Ordering Options

CCS130DR Mechanical-Bearing Direct Drive Rotary Collet Stage	
Stage Size (Required)	
-160	160 mm stage height
Cutting Configuration (Required)	
-DCUT	Dry cutting configuration
-WCUT	Wet cutting configuration with fluid rotary union
Note: -WCUT option requires a wet-cut seal with O-ring matched to a specific tube diameter	
Accessories (To be Ordered as a Separate Line Item)	
Collet-D-CLTxxx	Collet, Type-D; consult Aerotech for available sizes
RingSeal-D-RSxx	Ring seal; Type-D collet chuck
CGF	Collet and gripper filtration kit

Figure 1-1: Standard Features

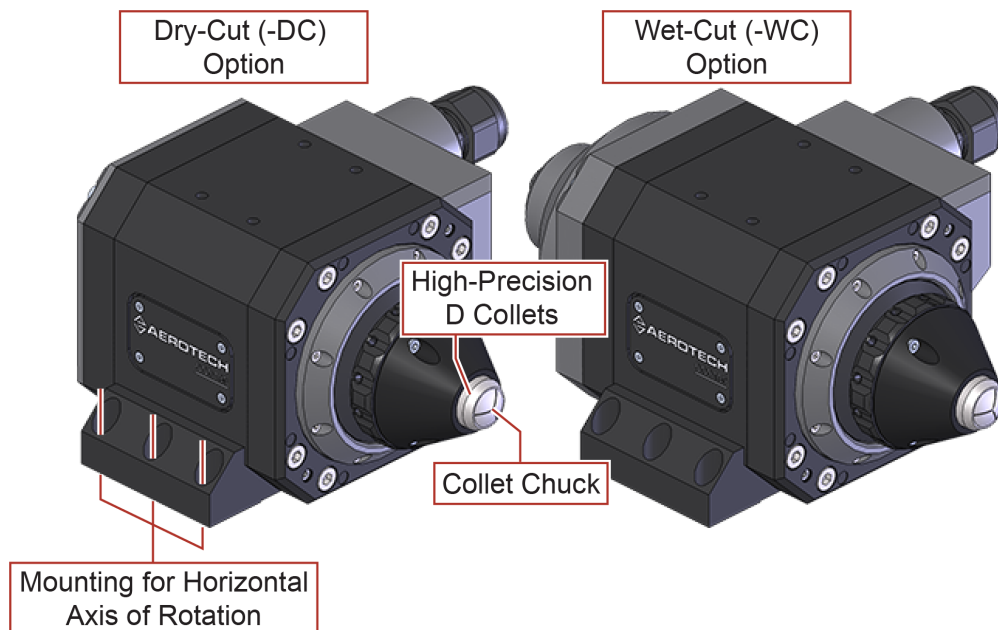

1.1. Environmental Specifications



WARNING: General Hazard Warning! Do not expose this product to environments or conditions outside of the listed specifications. You could damage the equipment if you exceed the environmental or operating specifications.



DANGER: Risk in Explosive Atmosphere!

- Standard Aerotech stage/motors are not rated for applications with explosive atmospheres such as airborne dust or combustible vapors.
- Do not operate stage/motors outside of Aerotech environmental specifications.

Table 1-2: Environmental Specifications

Ambient Temperature	Operating: 10 °C to 35 °C (50 °F to 95 °F)
	The optimal operating temperature is 20 °C \pm 2 °C (68 °F \pm 4 °F). If at any time the operating temperature deviates from 20 °C degradation in performance could occur.
	Storage: 0 °C to 40 °C (32 °F to 104 °F) in original shipping packaging
Humidity	Operating: 20% to 60% RH
	Storage: 10% to 70% RH, non-condensing in original packaging. The stage should be packaged with desiccant if it is to be stored for an extended time.
Altitude	Operating: 0 m to 2,000 m (0 ft to 6,562 ft) above sea level
	Contact Aerotech if your specific application involves use above 2,000 m or below sea level.
Vibration	Use the system in a low vibration environment. Floor or acoustical vibration can affect system performance. Contact Aerotech for information regarding your specific application.
Protection Rating	Limited protection against dust, but not water (IP50 equivalent ingress protection rating).
Use	Indoor use only

1.2. Accuracy and Temperature Effects

Aerotech products are designed for and built in a 20°C (68°F) environment. Temperature changes could cause a decrease in performance or permanent damage to the stage. At a minimum, the environmental temperature must be controlled to within 0.25°C per 24 hours to ensure the stage specifications are repeatable over an extended period of time. The severity of temperature effects on all specifications depends on many different environmental conditions, which include how the stage is mounted. Contact the factory for more details.

1.3. Basic Specifications

Table 1-3: CCS130DR Series Specifications

		CCS130DR-160
Travel		360° Continuous
Accuracy ⁽¹⁾		5 arc sec
Bidirectional Repeatability		2 arc sec
Maximum Speed ⁽²⁾		1000 rpm
Aperture ⁽³⁾		7.9 mm (Dry); 3 mm (Wet)
Maximum Torque (Continuous)		0.48 N·m
Load Capacity ⁽⁴⁾	Axial	2 kg
	Radial	0.5 kg
	Moment	0.75 N·m
Rotor Inertia (Unloaded)		0.0004 kg·m ²
Stage Mass		3.1 kg
Material		Hardcoat/Anodized Aluminum; Hardened Stainless Steel (Collet Chuck)
Mean Time Between Failure (MTBF)		10,000 Hours
Collet Type		Type D (Louis Levin & Sons™)
Collet Runout ⁽⁵⁾		<30 μm
System Air Pressure ⁽⁶⁾		100 psig
<p>(1) Calibrated accuracy; requires the use of Aerotech controls and angular programming units.</p> <p>(2) Maximum speed listed is stage and motor dependent (assuming a 340 V bus). Actual speed may be lower due to motor back emf. Consult Aerotech for more details.</p> <p>(3) Dry-Cutting (no ring seal installed) on a system with the -WCUT option limits tube size to 6.7 mm. Wet-cutting (ring-seal required and installed) on a system with the -WCUT option limits tube size to 3.0 mm.</p> <p>(4) Maximum loads are mutually exclusive. Loading limits are due to the collet chuck mechanism. Contact Aerotech directly if part load requirement exceeds specifications.</p> <p>(5) TIR of precision gauge pin in an ultra-precision collet. Measured 3 mm away from collet face at 80 psig applied air pressure for CCS130DR.</p> <p>(6) The CCS130DR-160 contains a collet chuck mechanism that is normally-open. Collet mechanism requires air to close collet chuck. Air supply must be dry (0° F dew point), oil-less air or 99.99% pure nitrogen. Air or nitrogen must be filtered to 1 micron particle size or better.</p>		

This page intentionally left blank.

Chapter 2: Installation



The stage installation must be in accordance with the instructions provided by this manual and any accompanying documentation. Failure to follow these instructions could result in injury or damage to the equipment.

2.1. Dimensions

Figure 2-1: CCS130DR Dimensions

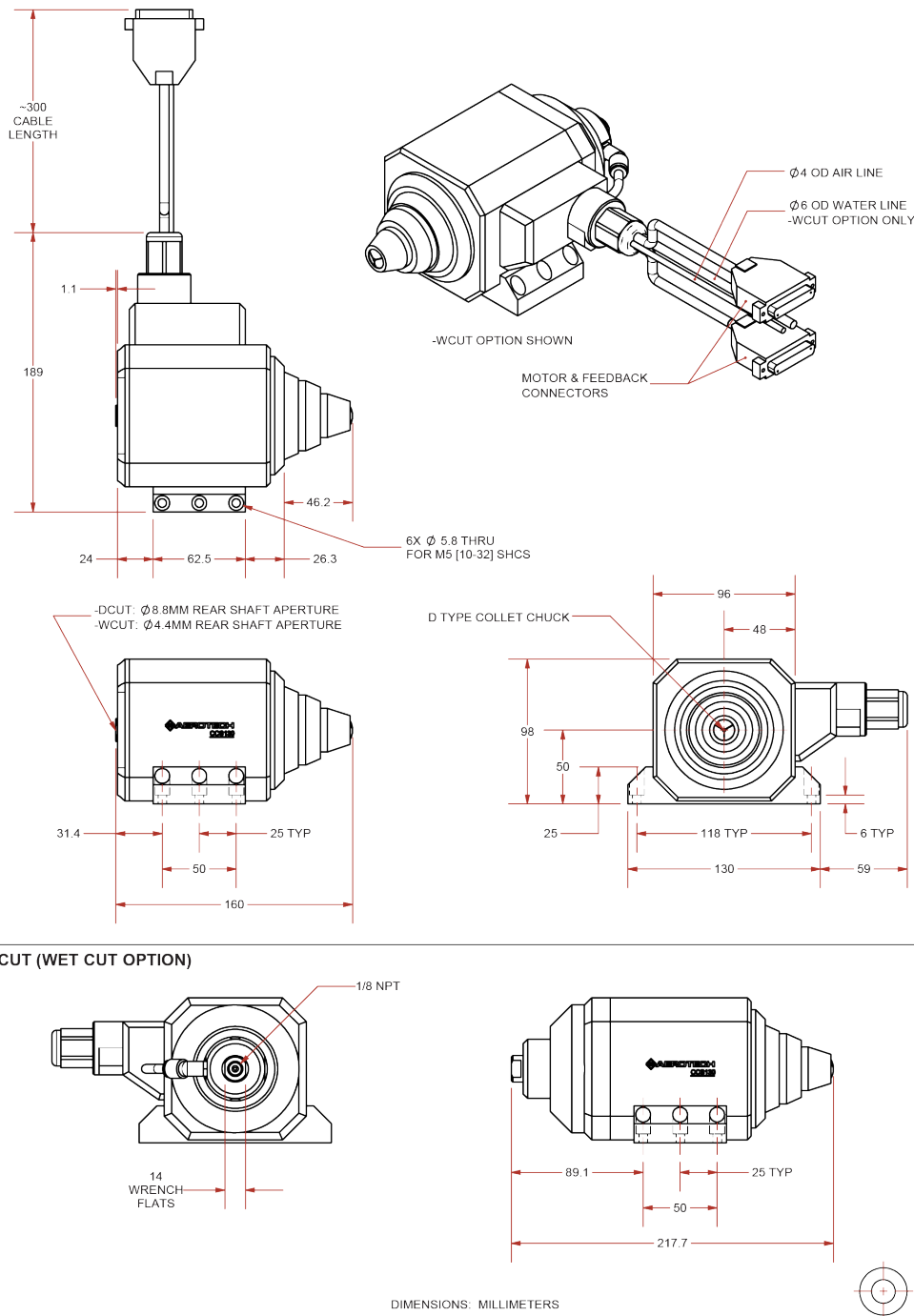

2.2. Securing the Stage to the Mounting Surface



DANGER: Mechanical Hazard!

Personnel must be made aware of the mechanical hazards during set up or when you do service to the stage.

- Do not manually move the stage if it is connected to a power source.
- The stage must be mounted securely. Improper mounting can result in injury and damage to the equipment.
- When you move the tabletop manually to do maintenance, this could expose the operator to pinch points. Refer to [Pinch Points](#) on [Page 12](#).

The mounting surface must be flat and have adequate stiffness to achieve the maximum performance from the stage. When it is mounted to a non-flat surface, the stage can be distorted while the mounting screws are tightened. This distortion will decrease overall accuracy. Adjustments to the mounting surface must be done before the stage is secured.

Inspect the mounting surface for dirt or unwanted residue and clean if necessary. Use precision flatstones on the mounting surface to remove any burrs or high spots. Clean the mounting surface with a lint-free cloth and acetone or isopropyl alcohol and allow the cleaning solvent to completely dry. Gently place the stage on the mounting surface.



IMPORTANT: The stage is precision machined and verified for flatness at the factory.

- Do not machine the stage housing. If you must machine a surface to achieve a required flatness, machine the mounting surface.
- Keep the use of shims to a minimum when you mount the stage to the mounting surface. The use of shims could reduce the rigidity of the system.

Table 2-1: Stage Mounting Surface Flatness Requirement

Stage	Flatness Requirement
All Frame Sizes	1 μm per 50 mm

CCS130DR series stages have a fixed mounting pattern available to secure the stage to a mounting surface. [Figure 2-2](#) shows the main mounting holes in the base of the stage. Tightening torque values for the mounting hardware are dependent on the properties of the surface to which the stage is being mounted. Values provided in [Table 2-2](#) are typical values and may not be accurate for your mounting surface. Refer to [Section 2.1](#) for specific model mounting locations and dimensions.

Table 2-2: Stage to Mounting Surface Hardware

Mounting Hardware	Typical Screw Torque
M5x0.8x14mm long [10-32x1/2 in long] SHCS	4.7 N•m

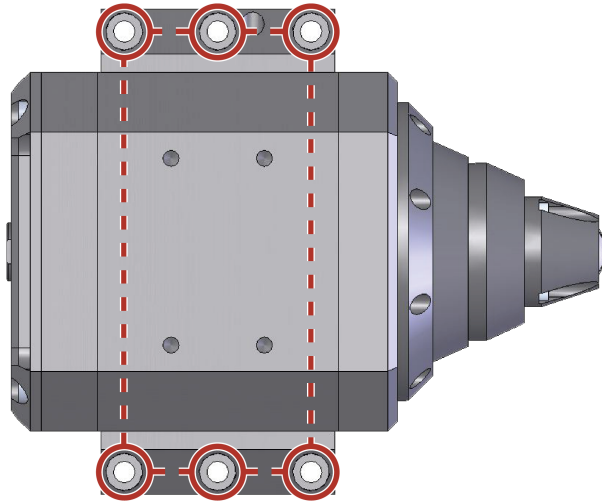
Figure 2-2: Stage Mounting Holes

2.3. Load Capability

The CCS130DR is designed for tubular manufacturing applications. With this in mind, the tubes loaded into the collet chuck of the rotary axis must fall within the maximum load parameters in [Section 1.3](#).



IMPORTANT: Maximum loads are mutually exclusive. Loading limits are due to the collet chuck mechanism. Contact Aerotech directly if part load requirement exceeds specifications.

If the CCS130DR-160 is configured for wet cut, it will have a rotary union attached to the end of the rotary shaft ([Figure 2-3](#)). A 1/8 in NPT tapped hole is provided on the end of the rotary union shaft to allow for connecting a pressure vessel or extension tube. To prevent damage or performance degradation of the stage, the unsupported length and weight of the attached pressure vessel is limited.

Aerotech recommends the size and weight limitations that follow for an unsupported pressure vessel.

- Length past end of rotary union (L): <200 mm
- Moment about end of rotary union (M): <0.75 N-m

If these limits are exceeded, it is recommended that an external steady-rest or support be implemented.

Figure 2-3: CCS130DR-160 Wet Cut Rotary Union Location

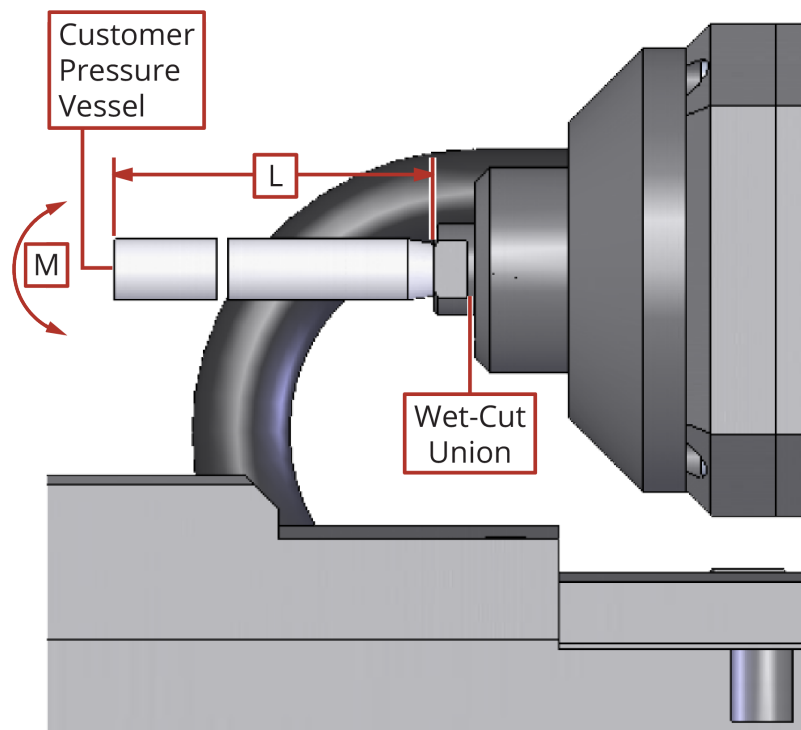

2.4. Air Requirements

The air pressure supplied to the collet chuck is important in ensuring that the material or tool is released properly.

- If compressed air is used, it must be filtered to 1 micron, dry to 0° F dew point, and oil free.
- If nitrogen is used, it must be 99.99% pure and filtered to 1 micron.

The chuck becomes fully closed at approximately 4-7 bar (60-100 psig) depending on the collet size. Higher pressures will not cause damage to the rotary union.

The supply pressure can be regulated to control the grip force on the workpiece material. Aerotech recommends using the minimum pressure required for the application that securely clamps the workpiece. Lower pressures reduce the possibility of damage to the workpiece, ensures the highest system performance, and increases the longevity of the system.

2.5. Wet Cut Fluid Requirements

Water or cutting fluid used during wet cut operations must be conditioned to meet certain requirements ensuring seal functionality and service life of the wet cut rotary union.

- Water or cutting fluid must be filtered to 5 microns or better.
- A fluid filter must be installed upstream of the rotary union between the pump outlet and the rotary union inlet.

2.6. Mechanical Setup

To prevent damage to the stage or parts, test the operation of the stage before any material is held in the collet.



WARNING: Remove the collet when first testing the operation of the stage. Closing the collet chuck on an empty collet can cause damage to the collet.

To operate the collet, nitrogen or clean, dry, oil-free compressed air must be supplied to the stage (refer to [Section 2.4.](#)).

The CCS130DR-160 stage features a 4 mm OD polyurethane air line that can be connected to the air supply.

Once an air supply is connected to the stage, the collet chuck can be actuated to check for proper operation. The CCS130DR-160 stage features a normally-open, air actuated collet chuck. Therefore, the collet chuck will remain open until air pressure is supplied to the stage. Turn the air supply on and off to check for proper operation of the collet chuck on this stage. The stage requires 60-100 psig to close.

Once you have verified that the collet chuck operates properly, a collet can be installed into the stage (refer to [Section 2.7.](#)). Appropriately sized material can then be inserted in to the collet. The collet chuck should again be checked for proper operation using the same procedures as before. Aerotech recommends turning the air pressure supply to 0 psi using a precision regulator and slowly increasing pressure until the material is clamped in the collet. Only the minimum amount of air pressure which properly secures the material for the application should be used and should not exceed the maximum system air pressure.



WARNING: The size of material should match the collet size and be inserted into the collet at least 2/3 the length of the collet bore. Material that is larger or smaller than the collet or not inserted far enough into the collet will affect system performance, particularly material runout. In worst-case scenarios, the collet could be damaged and have to be replaced.

2.7. Changing the Workholding Devices

CCS130DR-160 stages are designed to use Levin D-style collets. Levin Type D precision collets must be used to guarantee the collet runout specifications. Contact the factory for more details.



IMPORTANT: Different grip diameters are commonly available and can be interchanged.



DANGER: Electrical Shock Hazard!

- Do not connect or disconnect stage/motor interconnections while connected to a live electrical power source.
- Before you set up or do maintenance, disconnect electrical power.

Collet Removal Procedure

1. Disable and remove power from the stage.
2. Open the collet chuck to expose the front of the collet in the chuck.
3. Remove the collet from the chuck by turning it counter-clockwise.
4. Store the collet in a safe location so it will not be damaged. If the collet is going to be stored for an extended period of time or where moisture is present, it should be coated with a light film of rust preventative oil.

Collet Installation Procedure

1. Disable and remove power from the stage.
2. Clean the collet chuck taper and collet including the threads. Acetone or isopropyl alcohol may be used to clean the metal components. For optimum performance, the collet chuck taper and collet must be free of all dirt and debris.
3. Apply a small amount of general purpose, high viscosity grease or anti-seize lubricant to the collet chuck taper (refer to [Section 4.3.](#)).
4. Verify that the collet chuck is in the open position. Then, guide the collet into the stage ([Figure 2-4](#)) and thread it into the collet chuck. Thread the collet in until it bottoms out and then reverse 1/3 of a turn.
5. Insert the desired workpiece into the collet. Actuate the collet to the closed position to verify that the workpiece is clamped in the collet. Adjust the collet depth and/or air pressure as required.
6. Restore power to the stage.

Figure 2-4: Collet Installation

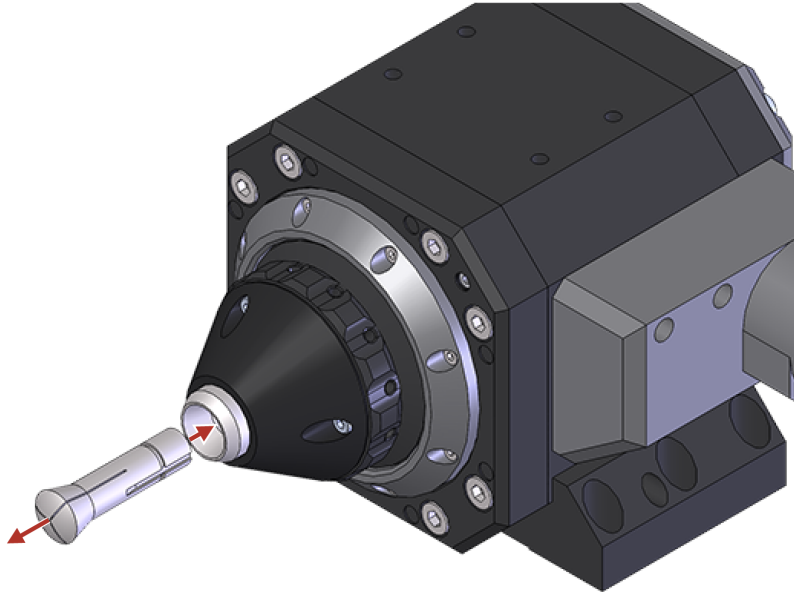

Chapter 3: Electrical Installation

DANGER: Electrical Shock Hazard!



- Stage motor phase voltage levels could be hazardous live.
- Personnel are protected from hazardous voltages unless electrical interconnections, protective bonding (safety ground), or motor/stage enclosures are compromised.
- Do not connect or disconnect stage/motor interconnections while connected to a live electrical power source.
- Before you set up or do maintenance, disconnect electrical power.
- It is the responsibility of the End User/System Integrator to make sure that stages are properly connected and grounded per Engineering Standards and applicable safety requirements.
- It is the responsibility of the End User/System Integrator to configure the system drive or controller within the Aerotech motor/stage electrical and mechanical specifications.

WARNING: General Hazard Warning!



Applications that require access to the CCS130DR must be restricted to qualified and trained personnel. The system integrator or qualified installer is responsible for determining and meeting all safety and compliance requirements when they integrate the CCS130DR into a completed system. Failure to do so could expose the operator to electrical or mechanical hazards.

Electrical installation requirements will depend on the ordered product options. Installation instructions in this section are for Aerotech products equipped with standard Aerotech motors intended for use with an Aerotech motion control system. Contact Aerotech for further information on products that are otherwise configured.

Aerotech motion control systems are adjusted at the factory for optimum performance. When the CCS130DR is part of a complete Aerotech motion control system, setup should only require that you connect the stage to the appropriate drive chassis with the cables provided. Labels on the system components should indicate the appropriate connections.

If system level integration was purchased, an electrical drawing that shows the system interconnects has been supplied with the system (separate from this documentation).

The electrical wiring from the motor and encoder are integrated at the factory. Refer to the sections that follow for standard motor wiring and connector pinouts.



IMPORTANT: Refer to the controller documentation to adjust servo gains for optimum velocity and position stability.

3.1. Motor and Feedback Connectors

Stages equipped with standard motors and encoders come from the factory completely wired and assembled.



IMPORTANT: Refer to the other documentation accompanying your Aerotech equipment. Call your Aerotech representative if there are any questions on system configuration.



IMPORTANT: If you are using standard Aerotech motors and cables, motor and encoder connection adjustments are not required.

The protective ground connection of the CCS130DR provides motor frame ground protection only. Additional grounding and safety precautions are required for applications requiring access to the stage while it is energized. The System Integrator or qualified installer is responsible for determining and meeting all safety and compliance requirements necessary for the integration of this stage into the final application.



DANGER: Electrical Shock Hazard!

- The protective ground connection must be properly installed to minimize the possibility of electric shock.
- The stage controller must provide over-current and over-speed protection. Failure to do so could cause electric shock or damage to the equipment.

Table 3-1: Brushless Motor Connector Pinout

Pin	Description	Connector
Case	Shield Connection	
A1	Motor Phase A	
A2	Motor Phase B	
A3	Motor Phase C	
1	Reserved	
2	Reserved	
3	Reserved	
4	Reserved	
5	Reserved	
A4	Frame Ground (motor protective ground)	

Table 3-2: Mating Connector Part Numbers for D-Style Motor Connectors

Mating Connector	Aerotech P/N	Third Party P/N
Backshell	ECK00656	Amphenol #17E-1726-2
Sockets [QTY. 4]	ECK00659	ITT Cannon #DM53744-6
Connector	ECK00657	ITT Cannon #DBM9W4SA197

Table 3-3: Feedback Connector Pinout

Pin	Description	Connector
Case	Shield Connection	
1	Reserved	
2	Over-Temperature Thermistor Sensor	
3	5V Power Supply Input (internally connected to Pin 16)	
4	Reserved	
5	Hall Effect Sensor (Phase B)	
6	MRK- (Encoder Marker-)	
7	MRK+ (Encoder Marker+)	
8	Reserved	
9	Reserved	
10	Hall Effect Sensor (Phase A)	
11	Hall Effect Sensor (Phase C)	
12	Reserved	
13	Reserved	
14	COS+ (Encoder Cosine+)	
15	COS- (Encoder Cosine-)	
16	5V Power Supply Input (internally connected to Pin 3)	
17	SIN+ (Encoder Sine+)	
18	SIN- (Encoder Sine-)	
19	Reserved	
20	Common ground (internally connected to Pin 21)	
21	Common ground (internally connected to Pin 20)	
22	Reserved	
23	Reserved	
24	Reserved	
25	Reserved	

Table 3-4: Mating Connector Part Numbers for D-Style Feedback Connectors

Mating Connector	Aerotech P/N	Third Party P/N
25-Socket D-Connector	ECK00300	FCI DB25S064TLF
Backshell	ECK00656	Amphenol 17E-1726-2

3.2. Motor and Feedback Wiring

Shielded cables are required for the motor and feedback connections.

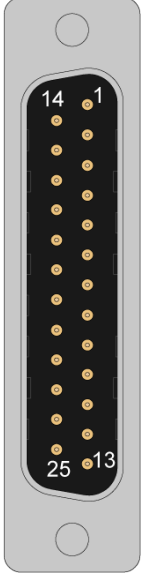
Figure 3-1: CCS130DR Motor and Feedback Wiring

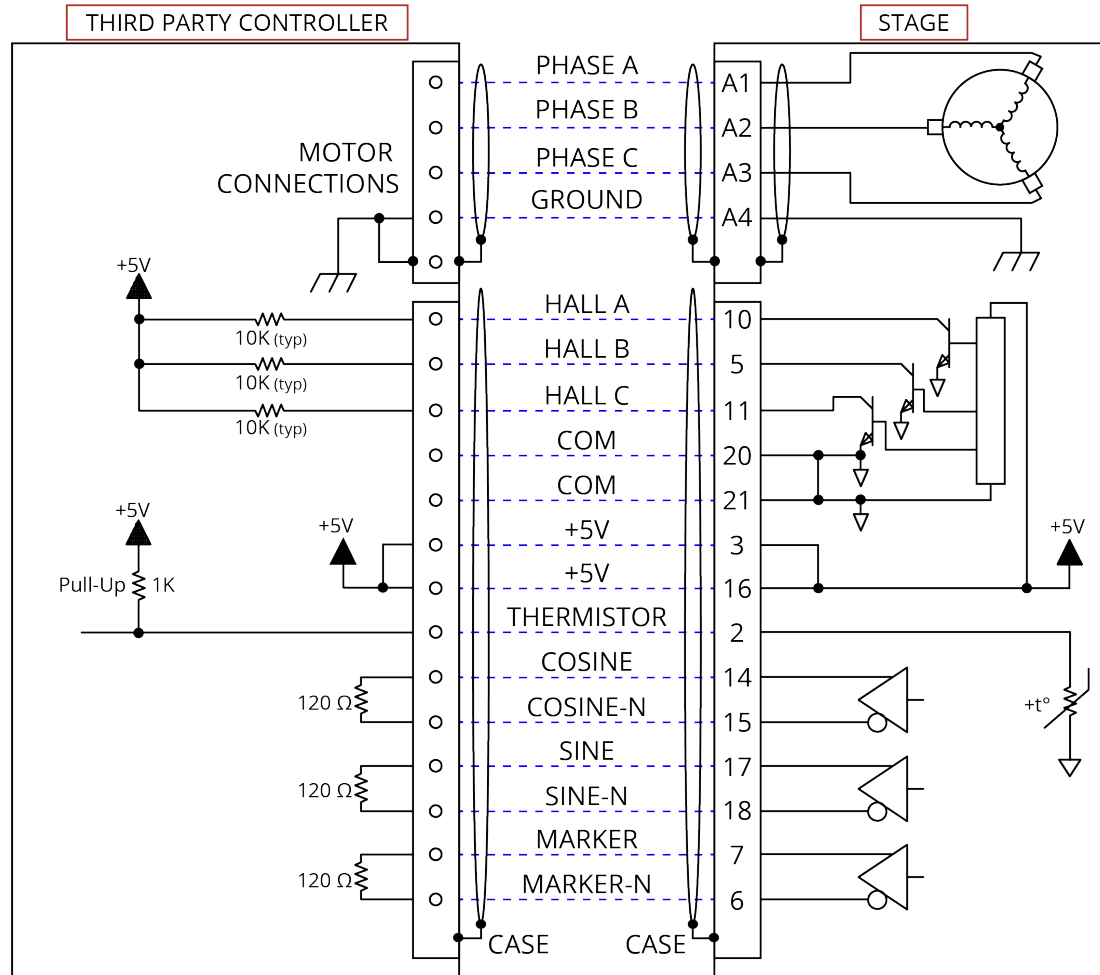

3.3. Motor and Feedback Specifications

All 5 V supplies share one common connection within the stage.

Table 3-5: Hall-Effect Sensor Specifications

	Specification
Supply Voltage	5 V \pm 5%
Supply Current	50 mA
Output Type	Open Collector
Output Voltage	24 V max (pull up)
Output Current	5 mA (sinking)

Table 3-6: Thermistor Specifications

	Specification
Polarity	Logic "0" (no fault)
	Logic "1" (over-temperature fault)
Cold Resistance	\sim 100 Ω
Hot Resistance	\sim 10 K
Note: 1K pull-up to +5V recommended.	

Table 3-7: Encoder Specifications

	Specification
Supply Voltage	5 V \pm 5%
Supply Current	250 mA (typical)
Output Signals	Sinusoidal Type (Incremental Encoder): Analog: SIN+, SIN-, COS+, COS-, 1V _{pk-pk} ; Digital (RS422): MRK+, MRK- signals.
Lines per Revolution ⁽¹⁾	6,330 lines/rev
<small>(1) Fundamental resolution of sine wave output from encoder shown. The value is controller-dependent.</small>	

Table 3-8: Motor Specifications

		S-76-35 (CCS130DR-160)
Performance Specifications		
Winding Designation		-A
Stall Torque, Cont.	N·m	0.48
Peak Torque	N·m	1.92
Electrical Specifications		
Winding Designation		-A
BEMF Const., line-line, Max	$V_{pk}/krpm$	29.1
Continuous Current, Stall	A_{pk}	2.0
	A_{rms}	1.4
Peak Current, Stall	A_{pk}	8.0
	A_{rms}	5.7
Torque Constant	$N·m/A_{pk}$	0.24
	$N·m/A_{rms}$	0.34
Motor Constant	$N·m/\sqrt{W}$	0.075
Resistance, 25 °C, line-line	Ω	10.5
Inductance, line-line	mH	1.40
Maximum Bus Voltage	VDC	340
Thermal Resistance	°C/W	1.83
Number of Poles	--	14
(1) All performance and electrical specifications have a tolerance of $\pm 10\%$. (2) Values shown at 75 °C temperature rise above a 25 °C ambient temperature, with housed motor mounted to a 250x250x6 mm ³ aluminum heat sink. (3) Peak torque assumes correct rms current; consult Aerotech. (4) Torque constant and motor constant specified at stall. (5) All Aerotech amplifiers are rated A_{pk} ; use torque constant in $N·m/A_{pk}$ when sizing.		

3.4. Limits, Marker, and Machine Direction

Aerotech stages are configured to have positive and negative "machine" directions. The machine direction defines the phasing of the feedback and motor signals and is dictated by the stage wiring (refer to [Section 3.2](#)). Programming direction of a stage is set by the controller that is used to move the stage. Programming direction is typically selectable in the controller, while machine direction is hardwired in the stage. [Figure 3-2](#) shows the machine direction of CCS130DR stages.

Figure 3-2: Machine Direction

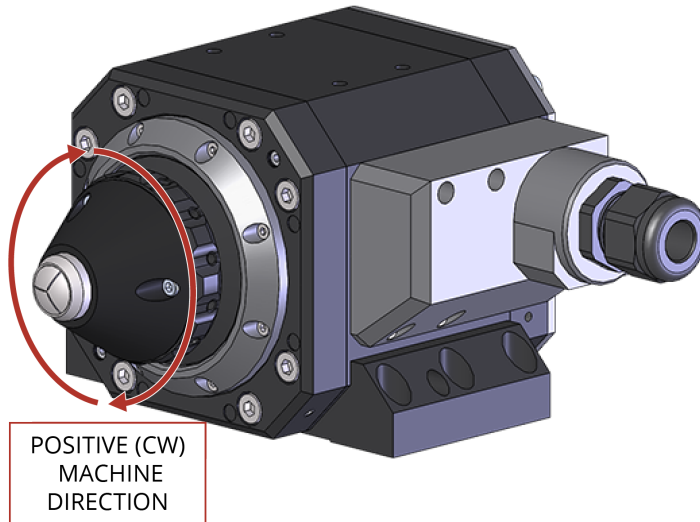

3.5. Motor and Feedback Phasing

Motor phase voltage is measured relative to the virtual wye common point.

Figure 3-3: Hall Phasing Diagram

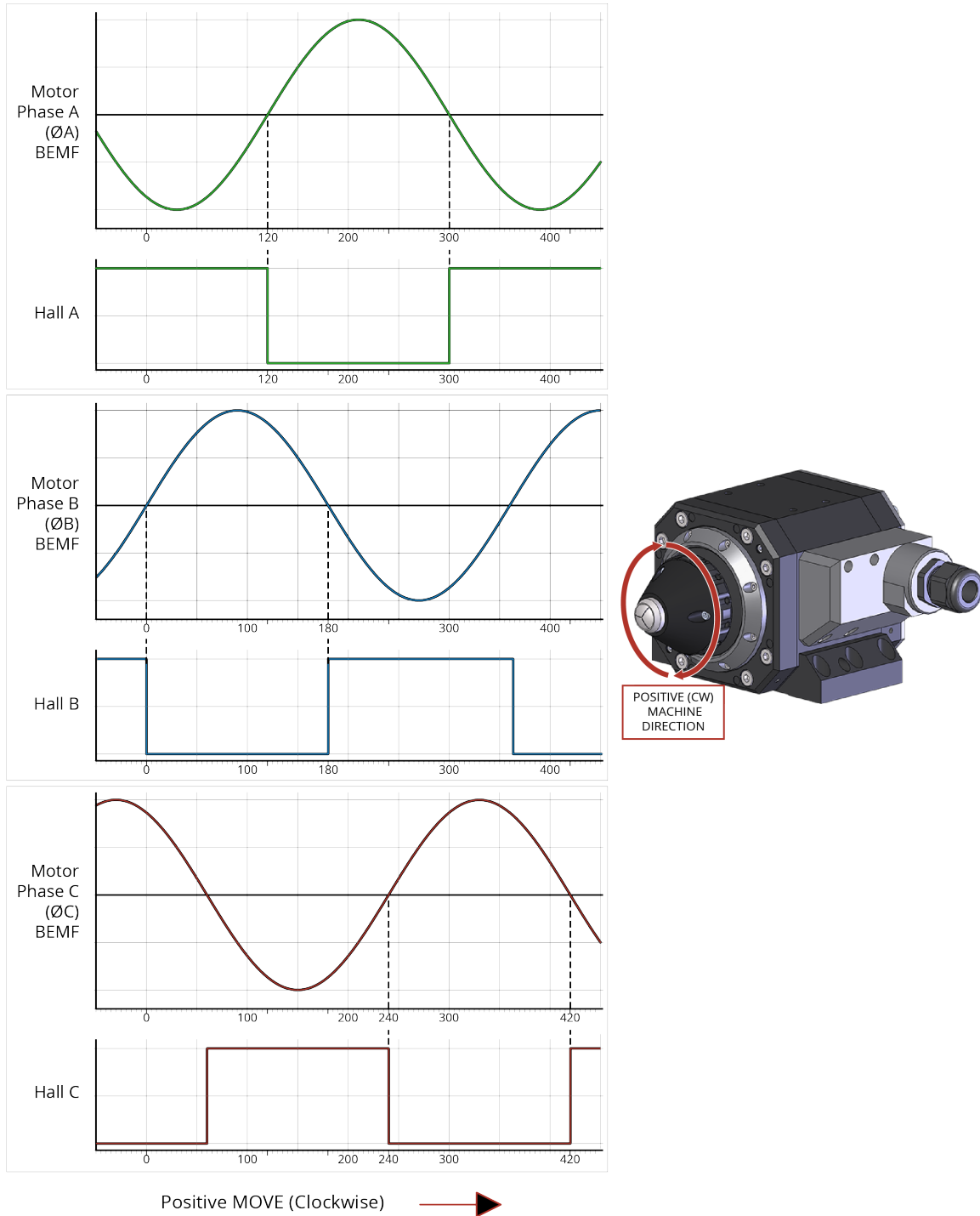
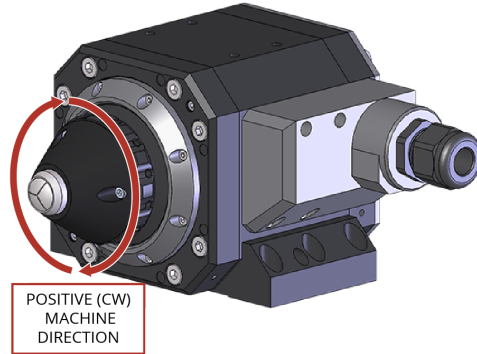
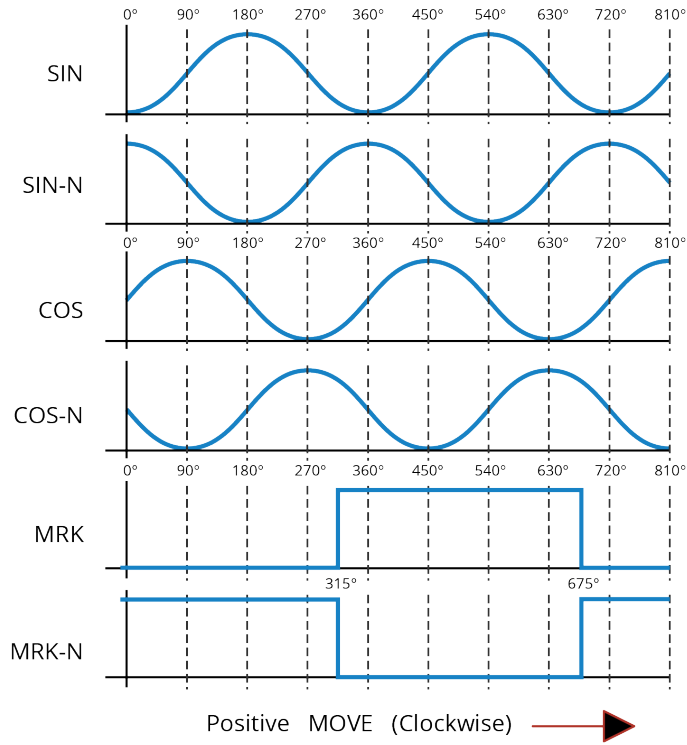

Figure 3-4: Encoder Phasing Reference Diagram (Analog/Sine Wave)



This page intentionally left blank.

Chapter 4: Maintenance



IMPORTANT: Read the [Safety Procedures and Warnings](#) (on [Page 8](#)) before you do maintenance to the stage.



IMPORTANT: Keep the bearing area free of foreign matter and moisture or the performance and life expectancy of the stage will be reduced.



DANGER: Electrical Shock Hazard!

- Do not connect or disconnect stage/motor interconnections while connected to a live electrical power source.
- Before you set up or do maintenance, disconnect electrical power.

The CCS130DR series stages are designed to require minimum maintenance. There are some items that may require preventative maintenance during the lifetime of the stage. This chapter will cover information about component maintenance and replacement, intervals between lubrication, detail the lubrication and inspection process, and specify recommended lubricants and cleaning solvents.



WARNING: Failure to follow the maintenance procedures outlined in this section will result in voiding stage warranty.

4.1. Service and Inspection Schedule

**DANGER: Electrical Shock Hazard!**

- Do not connect or disconnect stage/motor interconnections while connected to a live electrical power source.
- Before you set up or do maintenance, disconnect electrical power.

The inspection and cleaning interval depends on application conditions such as duty cycle, speed, and environment. You should frequently inspect and clean the CCS130DR series stage until a trend develops for the application. As part of the inspection process, the stage, cables, collet/collet chuck, and seals should be examined for wear, damage, and excessive air or water leakage. The bearings, motor, and encoder do not require any preventative maintenance. Once the stage condition has been assessed, the inspector should:

- Repair any damage before resuming operation of the stage
- Re-tighten loose connectors
- Replace or repair damaged cables
- Remove collet and inspect, clean, and relubricate collet and collet chuck
- Clean the stage and cables if needed

In general, repair and/or replacement of damaged or malfunctioning components by Aerotech field service personnel is not possible. Repair typically requires that the unit be returned to the factory. Please contact Aerotech Global Technical Support for more information.

4.2. Cleaning and Lubrication



DANGER: Electrical Shock Hazard! Before you do maintenance to the equipment, disconnect the electrical power.



IMPORTANT: Wear appropriate personal protective equipment (PPE) when you use cleaning solvents or lubricants.

Cleaning

When you clean components of the CCS130DR series stage:

1. Use a clean, dry, soft, lint-free cloth.
2. Before you use a cleaning solvent on any part of the stage, blow away small particles and dust with clean, dry, compressed air.
3. In applications that have multiple stages bolted together to form multi-axis systems, the orthogonality can be lost if the stage tables of the support stages are loosened. Precision aligned stages should not be loosened or disassembled.
4. We recommend that you do not disassemble the stage beyond the instructions given in this manual. Proper assembly and calibration can only be done at the factory. Contact Aerotech for more information.

Any metal surface on the stage can be cleaned with either acetone or isopropyl alcohol. Cleaning solvents, especially acetone, should not be used on any rubber components (o-rings and seals). If rubber components require cleaning, nitrogen or clean, dry, oil-less compressed air can be used to blow them off and a lint-free cloth or rag can be used to remove excess grease, oil, or other contaminants.



WARNING: General Hazard Warning!

- Make sure that all solvent has completely evaporated before you move the stage.
- DO NOT use acetone to clean the o-rings or seals.

Lubrication

O-rings and collet piston seals should be lubricated with Parker O-Lube lubricant or an equivalent o-ring lubricant.

The collet chuck taper should be lubricated with a general purpose, high viscosity grease or anti-seize lubricant (refer to [Table 4-1](#)).

Table 4-1: Recommended Lubricants

Vender	Product	Item #	Description
Henkel Technologies	Loctite	80209	Silver Grade Anti-Seize
Henkel Technologies	Loctite	51168	Food Grade Anti-Seize
Jet Lube	White Knight	16404	Food Grade Anti-Seize

If the application process uses only a small portion of travel for most of the duty cycle, periodically drive the stage through full travel to redistribute the lubrication in the bearings.

4.3. Collet & Collet Chuck Lubrication and Cleaning



WARNING: To prevent premature failure and wear that can void the warranty, lubricate and clean the collet interface surfaces as instructed in this section.

For the collet chuck and collet to operate properly, preventative maintenance and regular cleaning is required.

Before inserting any collet into the chuck, clean the chuck taper and the collet with acetone or isopropyl alcohol and a lint-free cloth. If required, nitrogen or clean, dry, oil-less compressed air can be used to clean out the collet grooves. Inspect the collet and the chuck interface surfaces to be sure no wear marks are present. If wear or fret marks (copper colored oxide marks) are present, the taper can be lightly polished with a fine-grit crocus cloth. The goal is to clean the surface of the taper and not to remove an excessive amount of material. If the wear marks are large, or excessive polishing is required to remove these marks, the collet chuck and collet may need to be replaced. Contact Aerotech Technical Support for more information. Wear and fretting can be prevented with proper lubrication and maintenance intervals.

After inspection and cleaning, grease the collet chuck taper and collet taper with a small amount of lubricant. Then, install the collet into the collet chuck (refer to [Section 2.7.](#)). Aerotech recommends using the lubricants listed in [Table 4-1.](#)

Lubricant inspection and replenishment depend on application conditions such as collet chuck duty cycle, clamping force (air pressure), and the machining environment. An inspection interval of once every 8 operational hours is recommended until a trend develops for the application. Longer or shorter intervals may be required to maintain a film of lubricant on the collet taper. The collet and chuck should also be cleaned and relubricated after sitting for an extended period of time without operation. If the lubrication sits for long periods of time, it can become dry and lose its lubrication properties. Insufficient lubrication will lead to wear, fretting corrosion, and sticking or lock-up of the collet closer. If this occurs, the machine should be immediately stopped and the collet and collet chuck cleaned and relubricated. It is also recommended that the collet and chuck interface surfaces be cleaned, inspected, and relubricated every time the collet is removed.

Figure 4-1: Collet and Collet Chuck Tapered Surfaces

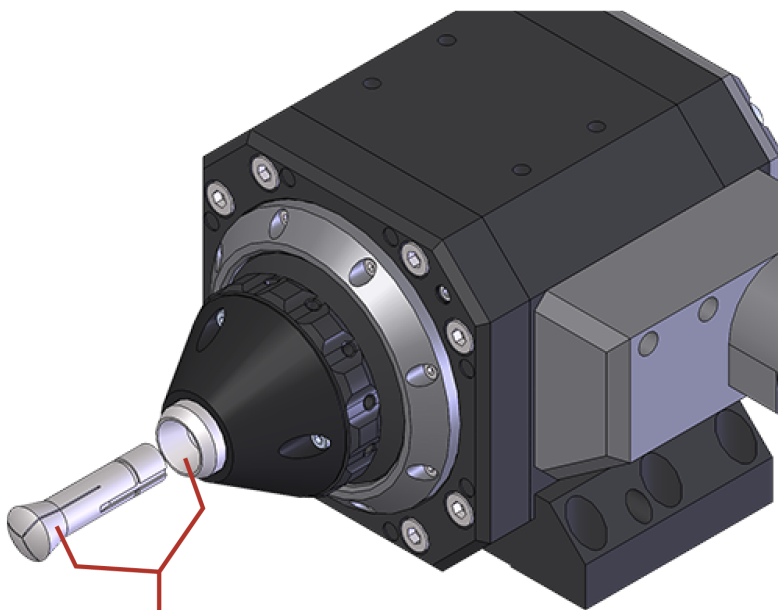

Apply lubricant to the tapered surfaces of the collet and collet chuck.

4.4. Seal Replacement

4.4.1. Piston Seal Change Procedure

The collet chuck and actuation mechanism on the CCS130DR series stages are equipped with o-ring seals that are designed to last many collet chuck (open/close) cycles. However, due to regular wear, the seals may require replacement during the lifetime of the product. If trouble with the piston seals is suspected, it is recommended that you contact Aerotech Technical Support. The seals should only be replaced by a qualified Aerotech technician.

4.4.2. Ringseal O-Ring Replacement (-WCUT option only)

During the lifetime of the stage, it may be necessary to change the ringseal o-rings. Contact Aerotech to obtain proper replacement seals. The ringseal screws into the center of the shaft from the front of the stage. Use the steps that follow to replace the o-ring.



DANGER: Electrical Shock Hazard!

- Do not connect or disconnect stage/motor interconnections while connected to a live electrical power source.
- Before you set up or do maintenance, disconnect electrical power.

1. Remove power to the stage.
2. Remove collet (See [Section 2.7.](#)).
3. With the collet removed, the ringseal will now be exposed. Using a 4 mm allen key or [WIHA Tool #54040] unscrew the ringseal from the shaft.

Figure 4-2: Ringseal Removal

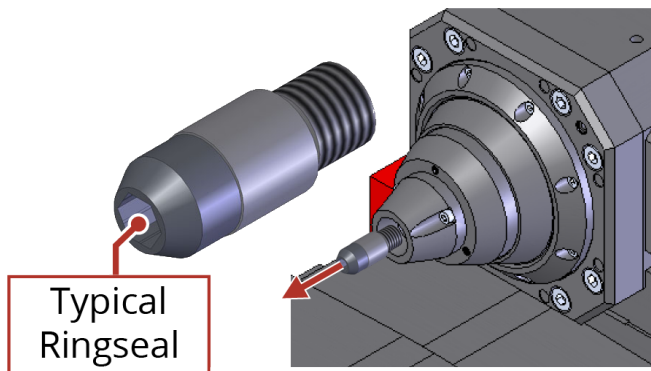

4. Remove the o-ring ringseal (shown in [Figure 4-3](#)). The replacement o-ring ringseal should be properly lubricated. The shaft o-ring is a static seal and provides secondary protection against leaks. This seal does not need to be replaced unless required. A long pick or thin screwdriver will be necessary to remove the shaft o-ring.
5. Wrap the ringseal threads with Teflon thread seal tape [PTFE tape] in preparation for installation.
6. Re-insert the ringseal into the inner collet housing and tighten into position.
7. Re-insert the collet.

Figure 4-3: Cross-section View of Ringseal Showing O-Rings

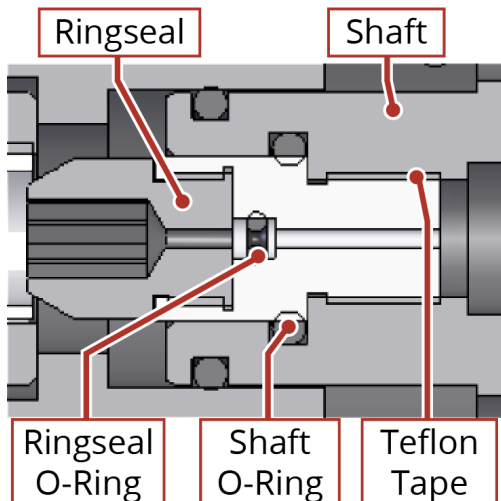

4.4.3. Wet Cut Rotary Union Seal Replacement (-WCUT option only)

The rotary seal in the wet cut rotary union requires periodic replacement. Contact Aerotech for obtaining appropriate replacement seals. Figure 4-4 shows a cross section of the rotary union assembly.



DANGER: The wet cut rotary union seal should be replaced and relubricated at a minimum of every 1000 hours of stage operation.

For heavy use or three shift operation: this corresponds to replacement every month.

For lighter use or single shift operation: this corresponds to replacement every three months.



DANGER: Electrical Shock Hazard!

- Do not connect or disconnect stage/motor interconnections while connected to a live electrical power source.
- Before you set up or do maintenance, disconnect electrical power.



WARNING: Failure to follow the maintenance procedures outlined in this section will result in voiding stage warranty.

Figure 4-4: Cross-Section View of Wet Cut Rotary Union

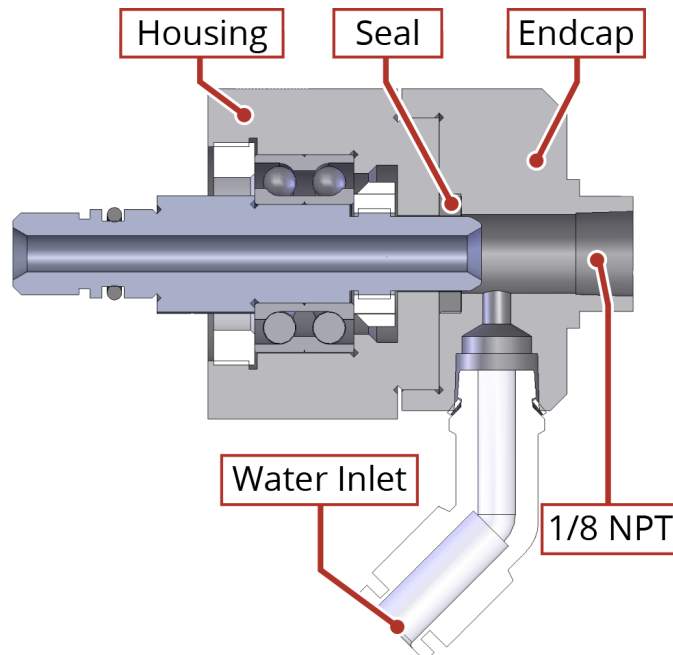

1. Remove power to the stage.
2. Purge water from inside stage. Care should be taken when doing this to prevent large amounts of water from being deposited on stage.
3. To access the rotary union seal, remove [QTY-4] M3 end cap mounting screws from the rear of the assembly and carefully pull the end cap off of the housing (refer to Figure 4-5).

Figure 4-5: Rear Carriage Cover w/ Wet Cut Rotary Union

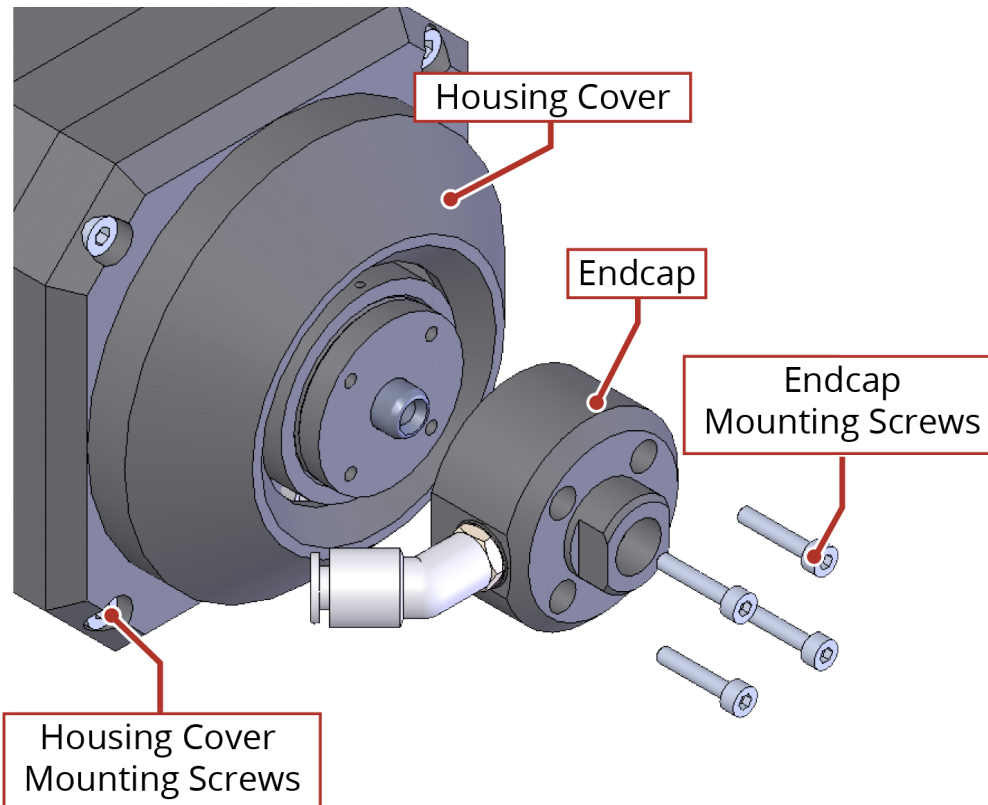

4. The rotary seal and rotary union shaft will now be exposed. Pry the rotary seal from end cap using care not to damage the sealing surfaces (see [Figure 4-6](#)).

Figure 4-6: Seal Location

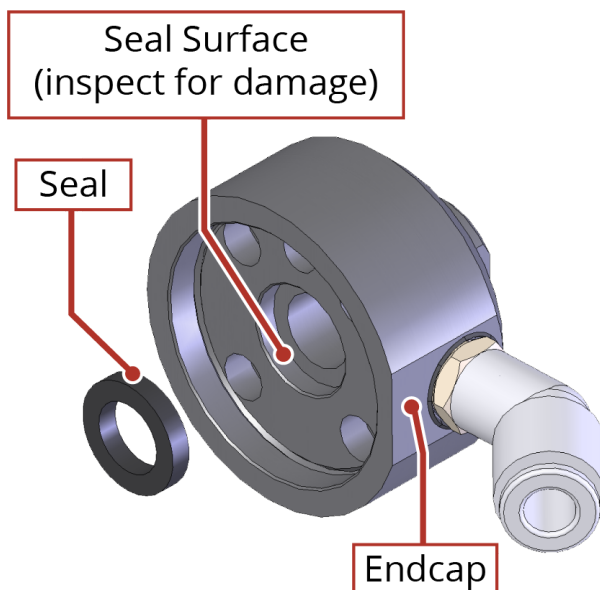

5. Inspect the shaft and seal surface for scratches or nicks (refer to [Figure 4-7](#)). Small wear marks are normal. If the shaft is undamaged, clean both the shaft and seal end cap surfaces with a lint-free rag and isopropyl alcohol. If the shaft is scratched (you can feel it with your fingernail), contact Aerotech Technical Support.

If advised to remove the rotary union, refer to [Section 4.5](#) for instructions.

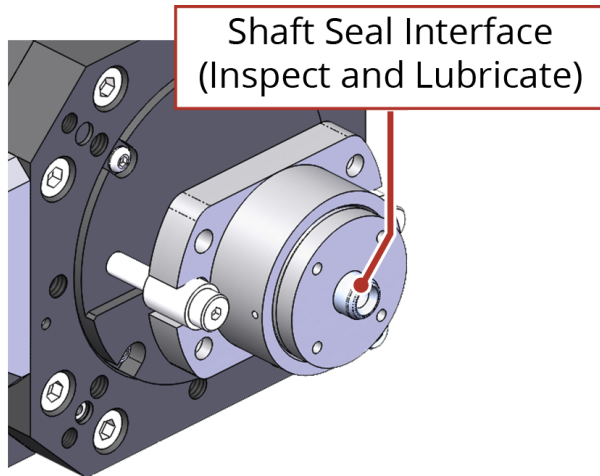
Figure 4-7: Wet Cut Rotary Union Shaft Inspection

6. Lubricate the new seal with a generous amount of Parker O-Lube and press it uniformly into its housing in the end cap.
7. Apply Parker O-Lube to the exposed end of the rotary union shaft as shown in [Figure 4-7](#).
8. Pilot the end cap back onto housing sub-assembly by using the rotary union shaft and housing. Use care when aligning the end cap so that damage does not occur to the newly installed seal.
9. Tighten the end cap screws and reconnect water supply.
10. Leak test stage prior to restoring stage power.

4.5. Wet Cut Rotary Union Removal

If the rotary union shaft becomes scratched or damaged, the rotary union must be replaced in order to properly seal the system (refer to [Figure 4-8](#) for a view of the rotary union assembly).



DANGER: Electrical Shock Hazard!

- Do not connect or disconnect stage/motor interconnections while connected to a live electrical power source.
- Before you set up or do maintenance, disconnect electrical power.

Figure 4-8: Wet Cut Rotary Union

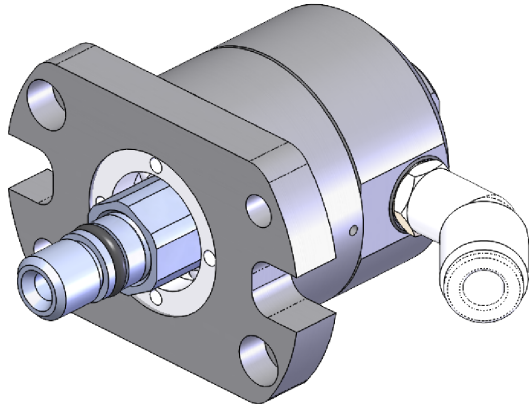

1. Remove power to the stage.
2. Purge water from inside stage. Care should be taken when doing this to prevent large amounts of water from being deposited on stage.
3. Remove [QTY. 4] M3 end cap mounting screws from the rear of the assembly and carefully pull the end cap off of the housing. Also remove [QTY. 4] M5 rear housing cover screws along with cover (refer to [Figure 1-2](#)).
4. Remove the shoulder bolts and bushings (refer to [Figure 4-9](#)).

Figure 4-9: Housing Assembly Showing Rotary Union

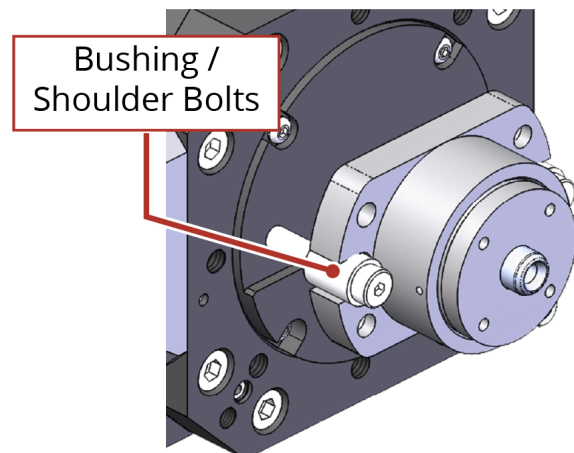

5. Using a 14 mm wrench on the rotary union nut and a 14 mm wrench on the CCS130DR shaft. Remove the wet cut rotary union from the CCS130DR shaft (see [Figure 4-10](#)).

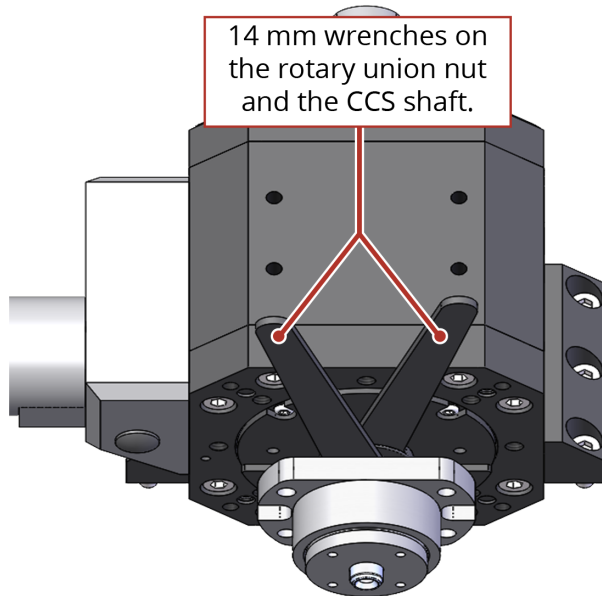
Figure 4-10: Rotary Union Removal

6. Install a new rotary union assembly by attaching it to the rear of the CCS130DR shaft. Tighten to 10 ft-lbs.
7. Reinstall shoulder bolts and bushings.
8. Reattach cover and end cap.
9. Leak test stage prior to restoring stage power.

4.6. Troubleshooting

Table 4-2: Troubleshooting

Symptom	Possible Cause and Solution
Stage will not move	Controller trap or fault (refer to the Controller documentation).
Stage moves uncontrollably	<ul style="list-style-type: none"> Encoder (sine and cosine) signal connections (refer to Chapter 3: Electrical Installation and Controller documentation). Motor Connections (refer to Chapter 3: Electrical Installation and the Controller documentation).
Stage oscillates or squeals	<ul style="list-style-type: none"> Gains misadjusted (refer to the Controller documentation). Encoder signals (refer to the Controller documentation).
Collet Chuck will not close	<ul style="list-style-type: none"> Insufficient air pressure supplied to the stage. Make sure there are no blockages in the supply line and the pressure is high enough (refer to Section 2.4.). Collet not threaded in all the way. Follow procedures in Section 2.7. to ensure collet is installed properly
Collet Chuck will not open	<ul style="list-style-type: none"> Insufficient air pressure supplied to the stage. Make sure there are no blockages in the supply line and the pressure is high enough (refer to Section 2.4.). The collet has not been lubricated properly or the lubrication needs to be replenished (refer to Section 4.2.).

Appendix A: Warranty and Field Service

Aerotech, Inc. warrants its products to be free from harmful defects caused by faulty materials or poor workmanship for a minimum period of one year from date of shipment from Aerotech. Aerotech's liability is limited to replacing, repairing or issuing credit, at its option, for any products that are returned by the original purchaser during the warranty period. Aerotech makes no warranty that its products are fit for the use or purpose to which they may be put by the buyer, whether or not such use or purpose has been disclosed to Aerotech in specifications or drawings previously or subsequently provided, or whether or not Aerotech's products are specifically designed and/or manufactured for buyer's use or purpose. Aerotech's liability on any claim for loss or damage arising out of the sale, resale, or use of any of its products shall in no event exceed the selling price of the unit.

THE EXPRESS WARRANTY SET FORTH HEREIN IS IN LIEU OF AND EXCLUDES ALL OTHER WARRANTIES, EXPRESSED OR IMPLIED, BY OPERATION OF LAW OR OTHERWISE. IN NO EVENT SHALL AEROTECH BE LIABLE FOR CONSEQUENTIAL OR SPECIAL DAMAGES.

Return Products Procedure

Claims for shipment damage (evident or concealed) must be filed with the carrier by the buyer. Aerotech must be notified within thirty (30) days of shipment of incorrect material. No product may be returned, whether in warranty or out of warranty, without first obtaining approval from Aerotech. No credit will be given nor repairs made for products returned without such approval. A "Return Materials Authorization (RMA)" number must accompany any returned product(s). The RMA number may be obtained by calling an Aerotech service center or by submitting the appropriate request available on our website (www.aerotech.com). Products must be returned, prepaid, to an Aerotech service center (no C.O.D. or Collect Freight accepted). The status of any product returned later than thirty (30) days after the issuance of a return authorization number will be subject to review.

Visit [Global Technical Support Portal](#) for the location of your nearest Aerotech Service center.

Returned Product Warranty Determination

After Aerotech's examination, warranty or out-of-warranty status will be determined. If upon Aerotech's examination a warranted defect exists, then the product(s) will be repaired at no charge and shipped, prepaid, back to the buyer. If the buyer desires an expedited method of return, the product(s) will be shipped collect. Warranty repairs do not extend the original warranty period.

Fixed Fee Repairs - Products having fixed-fee pricing will require a valid purchase order or credit card particulars before any service work can begin.

All Other Repairs - After Aerotech's evaluation, the buyer shall be notified of the repair cost. At such time the buyer must issue a valid purchase order to cover the cost of the repair and freight, or authorize the product(s) to be shipped back as is, at the buyer's expense. Failure to obtain a purchase order number or approval within thirty (30) days of notification will result in the product(s) being returned as is, at the buyer's expense.

Repair work is warranted for ninety (90) days from date of shipment. Replacement components are warranted for one year from date of shipment.

Rush Service

At times, the buyer may desire to expedite a repair. Regardless of warranty or out-of-warranty status, the buyer must issue a valid purchase order to cover the added rush service cost. Rush service is subject to Aerotech's approval.

On-site Warranty Repair

If an Aerotech product cannot be made functional by telephone assistance or by sending and having the customer install replacement parts, and cannot be returned to the Aerotech service center for repair, and if Aerotech determines the problem could be warranty-related, then the following policy applies:

Aerotech will provide an on-site Field Service Representative in a reasonable amount of time, provided that the customer issues a valid purchase order to Aerotech covering all transportation and subsistence costs. For warranty field repairs, the customer will not be charged for the cost of labor and material. If service is rendered at times other than normal work periods, then special rates apply.

If during the on-site repair it is determined the problem is not warranty related, then the terms and conditions stated in the following "On-Site Non-Warranty Repair" section apply.

On-site Non-Warranty Repair

If any Aerotech product cannot be made functional by telephone assistance or purchased replacement parts, and cannot be returned to the Aerotech service center for repair, then the following field service policy applies:

Aerotech will provide an on-site Field Service Representative in a reasonable amount of time, provided that the customer issues a valid purchase order to Aerotech covering all transportation and subsistence costs and the prevailing labor cost, including travel time, necessary to complete the repair.

Service Locations

<https://www.aerotech.com/contact-sales.aspx?mapState=showMap>

USA, CANADA, MEXICO

Aerotech, Inc.
Global Headquarters

CHINA

Aerotech China
Full-Service Subsidiary

GERMANY

Aerotech Germany
Full-Service Subsidiary

TAIWAN

Aerotech Taiwan
Full-Service Subsidiary

UNITED KINGDOM

Aerotech United Kingdom
Full-Service Subsidiary

Appendix B: Revision History

Revision	General Information
2.00	General manual update.
1.04	Revision changes have been archived. If you need a copy of this revision, contact Aerotech Global Technical Support.
1.03	
1.02	
1.01	
1.00	

This page intentionally left blank.

Index

	2			F	
2006/42/EC		6		field service	38
	A			H	
Accuracy and Temperature Effects		16		Hall-Effect Sensors Specifications	31
Accuracy of the Ballscrew		16		Handling	13
air				Humidity	16
compressed		23		I	
nitrogen		23		integrated collet retention	25
Air Requirements		23		L	
Altitude		16		label	13
Ambient Temperature		16		Levin D-style collets	25
	C			load capability	
cleaning				rotary union	22
collet/collet chuck		40		lubrication	
mounting surface		20		collet/collet chuck	40
Cleaning		39		Lubrication	39
cleaning solvent		39		M	
Collet				Motor-Related Warnings	11
Levin D-style		25		mounting surface	
collet retention		25		cleaning	20
collet/collet chuck				securing stage	20
cleaning		40		multiaxis combinations	39
lubrication		40		N	
compressed air		23		nitrogen	23
	D			P	
Dimensions		19		packing list	13
Directive 2006/42/EC		6		part number	13
	E			Performance Specifications	
Electrical Installation		27		S-76	32
Electrical Specifications				piston seal replacement	41
S-76		32		pressure vessel length/weight limits	22
Electrical Warnings		10		Protection Rating	16
EN 60204-1 2010		6-7		protective ground connection	28
EN ISO 12100 2010		6-7			
Encoder Specifications		31			
EU 2015/863		6			

R	
ringseal o-ring replacement	42
rotary union	
load capability	22
pressure vessel length/weight limits	22
S	
S-76	
Electrical Specifications	32
Performance Specifications	32
seal replacement	41
serial number	13
shims	20
Specifications	17
Encoder	31
Hall-Effect Sensors	31
Thermistor Specifications	31
stabilizing stage	14
stage	
distortion	20
stabilizing	14
Storage	13
T	
Table of Contents	3
Temperature Effects	16
Thermistor Specifications	31
Troubleshooting	48
V	
Vibration	16
W	
Warnings	8
Warranty and Field Service	49
Wet Cut Fluid Requirements	23
wet cut rotary union removal	46
wet cut rotary union seal replacement	43