

AeroAlign Optical Alignment Algorithms

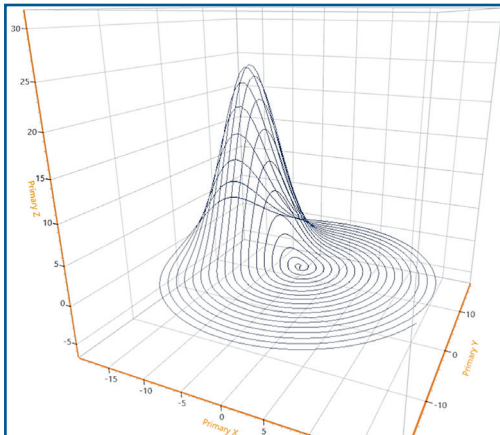

AeroAlignSpiral
2D First Light or Peak-Finding

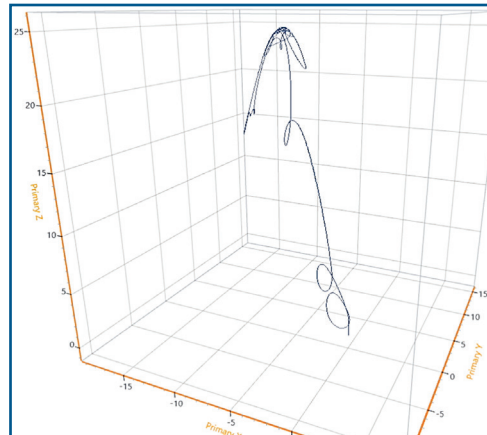

AeroAlignDynamic
2D Peak-Finding

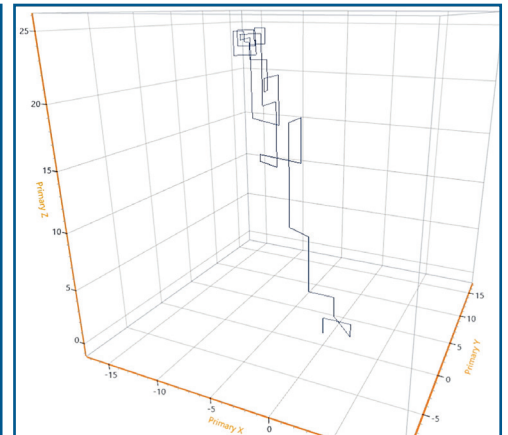

AeroAlignFast
Multi-Dimensional Peak-Finding

Signal Optimization, Automated

AeroAlign optical alignment algorithms are purpose-built to solve complex photonic alignment challenges. Compatible with any system running on the Automation1 motion control platform, AeroAlign algorithms support a wide variety of serial and parallel kinematic systems and offer a range of configurable parameters to optimize your process.



AeroAlign1D
1D First Light or Peak-Finding

Key Features:

- ◆ **Purpose-built algorithms** for automated first light & peak-finding active alignment
- ◆ Support for mechanical systems in **serial, parallel, and hybrid kinematic arrangements**
- ◆ Design and test processes in virtual environments with **signal simulation functionality**
- ◆ Flexible configurations & adjustable parameters to **tailor algorithms to your process needs**
- ◆ Task-level functions in Automation1 controller for **simultaneous deployment of multiple algorithms for multi-channel alignments**
- ◆ Compatible with both **PC- & drive-based control configurations** enabled by zero-jitter, HyperWire® connectivity



One Controller for All Motion

The Automation1 motion controller coordinates up to 32 axes of motion simultaneously, including serial kinematic systems, hexapods, laser scan heads and more. Automation1 tightly integrates precision motion with process control, featuring interface options including drive-based I/O and industrial Ethernet buses. Use built-in data capture tools to monitor, record and analyze system performance for process traceability and continuous improvement.

HyperWire Connectivity at 100 kHz

Aerotech's Automation1 HyperWire motion control bus is the fastest, highest-throughput communication bus in motion control. Using fiber optics, HyperWire provides distributed multi-input, multi-output (MIMO) motion control at the speed of light, enabling 20x the throughput of 100BASE-T Ethernet. With a 100 kHz cycle time and patented zero-jitter technology, HyperWire controls up to 32 axes of motion with no performance loss.

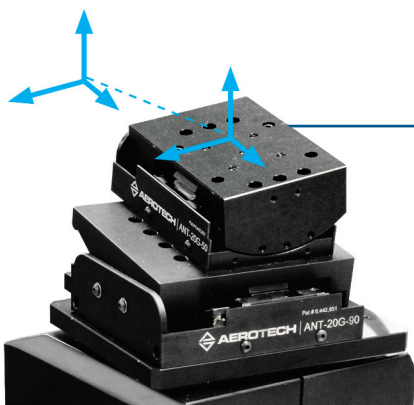
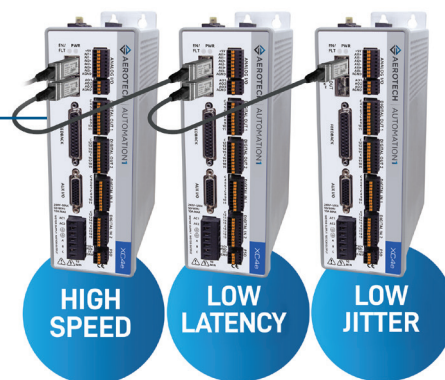

Advanced Algorithms for Coordinated Motion

Automation1's AeroScriptPlus advanced control algorithms streamline system setup and configuration with built-in capabilities. Tool Center Point Programming simplifies pivoting your motion system around the process focal point, eliminating the need to perform complex linear algebra to optimize positioning.

Flexible for R&D, Robust for Production

Designed for multi-axis positioning flexibility and tens of thousands of hours of continuous operation, Aerotech's ANT stages excel in R&D labs and full-scale production environments. With nanometer-level accuracy and incremental step size capabilities, these modular, direct-drive nanopositioning solutions enable high-precision alignment for your optical device test and assembly processes at speeds necessary to sustain high-throughput manufacturing operations.

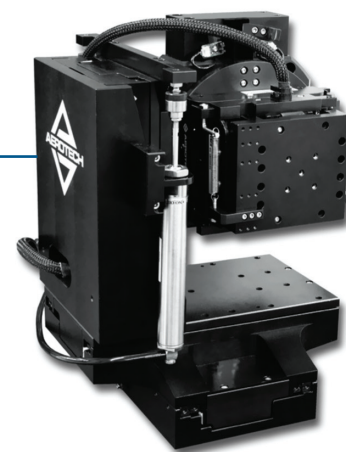

Learn more about AeroAlign optical alignment algorithms by using the QR code or visiting us at:

AEROTECH.COM

