MX MULTIPLIER BOARD

OPTION MANUAL

P/N: EDO108 (V1.3a)



AEROTECH, Inc. • 101 Zeta Drive • Pittsburgh, PA. 15238-2897 • USA
Phone (412) 963-7470 • Fax (412) 963-7459
Product Service: (412) 967-6440; (412) 967-6870 (Fax); (412) 967-6427 (BBS)

MX Multiplier is a product of Aerotech, Inc.

The MX Multiplier Board Option Manual Revision History:

Rev 1.0	April 24, 1996
Rev 1.1	November 07, 1996
Rev 1.2	June 16, 1997
Rev 1.3	January 26, 1998
Rev 1.3a	February 16, 2000

TABLE OF CONTENTS

CHAPTER 1: DESCRIPTION AND CONFIGURATION 1-1

- 1.1. Introduction 1-1
- 1.2. Multiplier Signals 1-2
- 1.3. Multiplier Board Setup 1-3
- 1.4. Hardware Configurations..... 1-3
 - 1.4.1. Fault Circuitry (JP1)..... 1-3
 - 1.4.2. Marker Pulse Jumper (JP4)..... 1-3
 - 1.4.3. Pulse Width Jumpers (JP2 & JP3)..... 1-4
 - 1.4.4. Test Points..... 1-5
 - 1.4.5. Connectors (J1 & J2)..... 1-5
 - 1.4.6. Potentiometers..... 1-7
 - 1.4.7. The RCN Resistor Network 1-8
- 1.5. Output Pulse Clock Speed 1-8
- 1.6. MX Multiplier Board Specifications 1-10
- 1.7. Physical Dimensions..... 1-11
- 1.8. Part Number and Ordering Information..... 1-11

APPENDIX A: WARRANTY AND FIELD SERVICE POLICY.....A-1

INDEX

▽ ▽ ▽

LIST OF FIGURES

Figure 1-1. MX Multiplier Board..... 1-1
Figure 1-2. MX Multiplier Board Configuration 1-2
Figure 1-3. Plot of Input and Output Signals 1-2
Figure 1-4. MX Multiplier Board Hardware Locations 1-4
Figure 1-5. MX Encoder Cable Pinouts 1-7
Figure 1-6. RCN Resistor Network..... 1-8
Figure 1-7. Count Spacing 1-9
Figure 1-8. MX Multiplier Dimensions..... 1-11

▽ ▽ ▽

LIST OF TABLES

Table 1-1. Settings for Pulse Width Jumpers (Rev A and Later) 1-4
Table 1-2. MX Multiplier Board Test Points 1-5
Table 1-3. Pinouts for Connectors (J1 & J2)..... 1-6
Table 1-4. MX Multiplier Board Potentiometers 1-7
Table 1-5. MX Multiplier Board Models and Specifications..... 1-10
Table 1-6. MX Multiplier Board and Resistor Network Part Numbers 1-12

▽ ▽ ▽

CHAPTER 1: DESCRIPTION AND CONFIGURATION**In This Section:**

- Introduction..... 1-1
- Multiplier Signals..... 1-2
- Hardware Configurations 1-3
- Output Pulse Clock Speed..... 1-8
- MX Multiplier Board Specifications..... 1-10
- Physical Dimensions 1-11
- Part Number and Ordering Information 1-11

1.1. Introduction

The MX multiplier board is designed to be used with sine wave encoders to increase the resolution of the encoder. There are four models available in the MX series, each providing different multiplication factors. Depending on the model, the user can get times 5, times 10, times 25, and times 50 multiplication. When used with an appropriate controller, the quadrature of the output signals provides an additional times 4 factor to yield the effective multiplication of times 20, times 40, times 100, and times 200. An MX multiplier board is shown in Figure 1-1.



Figure 1-1. MX Multiplier Board

The MX multiplier board connects between the encoder and the appropriate axis controller. Refer to Figure 1-2 for an example configuration. This connection does not affect Hall effect or limit signals, it is a simple add-in that uses mostly standard cables.

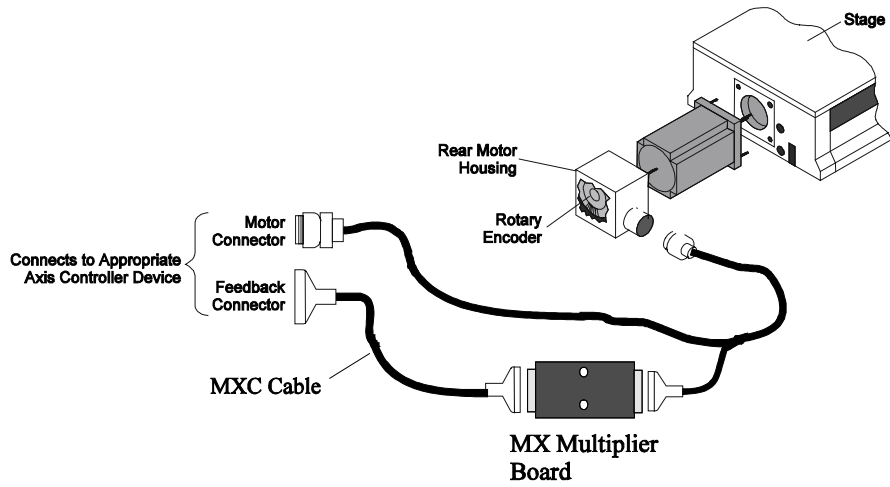

Figure 1-2. MX Multiplier Board Configuration

1.2. Multiplier Signals

The multiplier board accepts either voltage or current input signals and the resistor network values are set according to the input signal type. Refer to Section 1.4.7 for the appropriate values. The outputs are square wave, RS-422 TTL compatible signals. The input marker signal is expected to be active high and located in the middle of the electrical cycle. The plots illustrated in Figure 1-3 show the input and output signals (cosine, sine, and marker) for one electrical cycle of the MX5 multiplier box.

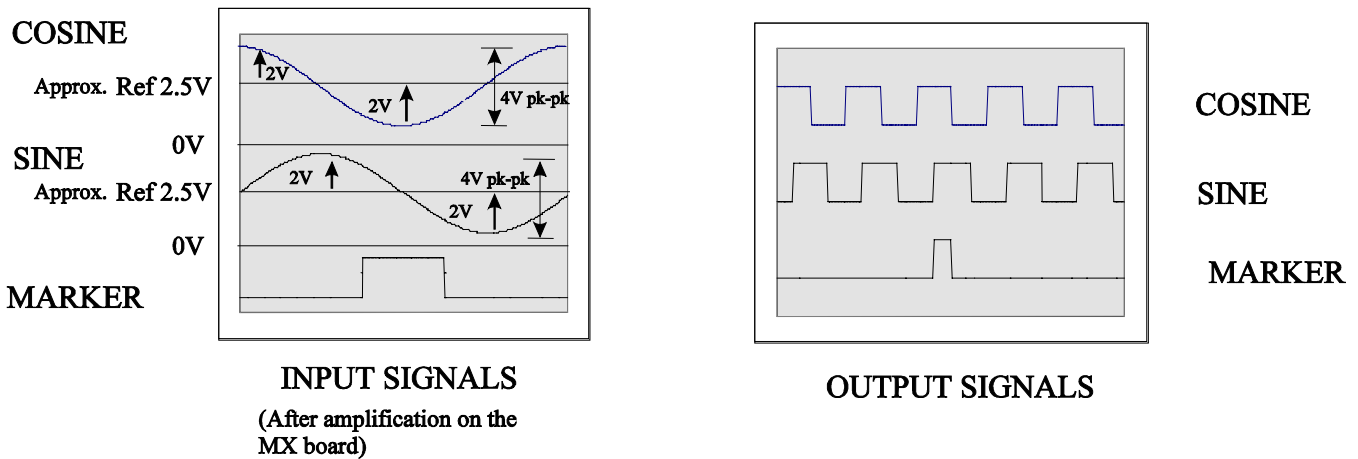

Figure 1-3. Plot of Input and Output Signals

1.3. Multiplier Board Setup

The type of input signals determines the components of the headers, RCN1, RCN2, and RCN3. Refer to Section 1.4.7. to select the correct component values. The amplified input signals are available at test points TP9 (sine) and TP10 (cosine) and are set by adjusting the potentiometers. While the motor is turning, perform the following:

1. Adjust the pot R14 (refer to Figure 1-4) to set the phase between the input sine and cosine signals to 90 degrees.
2. Referencing the oscilloscope connected to test point TP5 (approx. 2.5V), adjust pot R15 to remove offset of cosine signal (TP10).
3. Adjust the gain for the cosine signal to be a 4V peak-to-peak signal by adjusting pot R16.
4. Referencing the oscilloscope connected to test point TP5 (approx. 2.5V), adjust pot R17 to remove offset of sine signal (TP9).
5. Adjust the gain for the sine signal to be a 4V peak-to-peak signal by adjusting pot R18.

1.4. Hardware Configurations

The amplified input signals at Test points TP9 and TP10 should be configured for normal 4V peak-to-peak signals, see explanation in section 1.3. However, the multiplier board has an acceptable range of amplified input signals from 2V peak-to-peak to 4.5V peak-to-peak.

The following sections discuss the hardware used to configure the MX multiplier board. The hardware is accessible by removing two screws securing the dust cover to the board.

1.4.1. Fault Circuitry (JP1)









The fault circuitry detects input signal magnitudes below .5 Volt peak-to-peak. If a fault is detected, all outputs are set to a high impedance state. Jumper JP1 is set to position 1-2 (default), this enables fault detection. Setting JP1 to position 2-3 defeats fault detection. For jumper location, refer to Figure 1-4.

1.4.2. Marker Pulse Jumper (JP4)

The marker pulse jumper in the default setting of 1-2 sets the pulse width to the minimum pulse width. In this case, the marker is one output pulse wide and is qualified with the input marker. When set to position 2-3, the marker signal of the encoder is an output and is the same width as the input pulse and no qualification is performed. For jumper location, refer to Figure 1-4.

1.4.3. Pulse Width Jumpers (JP2 & JP3)

Table 1-1. Settings for Pulse Width Jumpers (Rev A and Later)

JP2	JP3	Function
		Minimum pulse width = 0.0625 μ s (default) Master clock frequency = 16 MHz (default)
		Minimum pulse width = 0.125 μ s Master clock frequency = 8 MHz
		Minimum pulse width = 0.25 μ s Master clock frequency = 4 MHz
		Minimum pulse width = .5 μ s Master clock frequency = 2 MHz



Rev - boards use position 1-2 for jumper “IN” and position 2-3 for jumper “OUT” on jumpers JP2 and JP3.

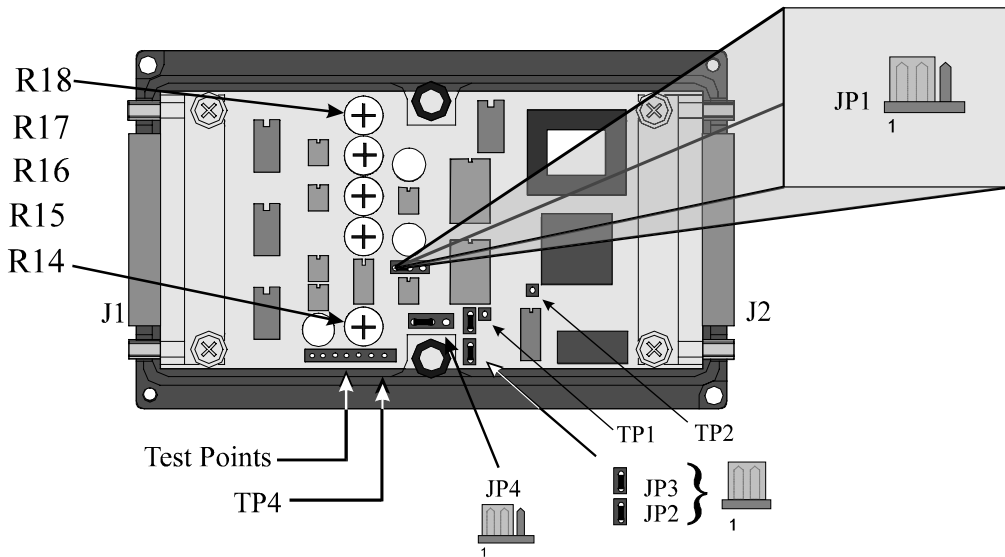

Figure 1-4. MX Multiplier Board Hardware Locations

1.4.4. Test Points

Table 1-2 lists the test points available on the MX multiplier boards.

Table 1-2. MX Multiplier Board Test Points

Test Points	Function
TP4	Ground
TP5	Reference (Approx. 2.5V)
TP6	Squared up marker signal from encoder
TP7	Mode signal from Xilinx chip (reserved)
TP8	1 MHz clock (reserved)
TP9	Amplified input sine wave (0 - 5V)
TP10	Amplified input cosine wave (0 - 5V)
TP1	Output cosine, square wave
TP2	Output sine, square wave

1.4.5. Connectors (J1 & J2)

There are two connectors on the MX multiplier board; J1 which receives signals from the encoder and J2 which is the output connector. J1 is a 25-pin female “D” style connector. J2 is a 25-pin male “D” style connector. Both connectors have the same pinouts, refer to Table 1-3. The MX board only uses the sine, cosine, and marker signals. The rest of the signals are connected directly between J1 and J2. This allows signals like Hall effects and limits to pass directly through the multiplier board, simplifying the wiring. Figure 1-5 is an illustration of the MX encoder cable with the pinouts.

Table 1-3. Pinouts for Connectors (J1 & J2)

Pin	Description	Pin	Description
1	Shield	13	
2		14	Cosine +
3	Encoder +5V (power source from J1)	15	Cosine -
4	Ground	16	+5V
5	Hall effect B *	17	Sine +
6	Marker -	18	Sine -
7	Marker +	19	
8		20	Ground
9		21	Ground
10	Hall effect A *	22	Home limit *
11	Hall effect C *	23	
12	CW limit *	24	CCW limit *
		25	

* These signals do not connect to the MX multiplier circuitry.

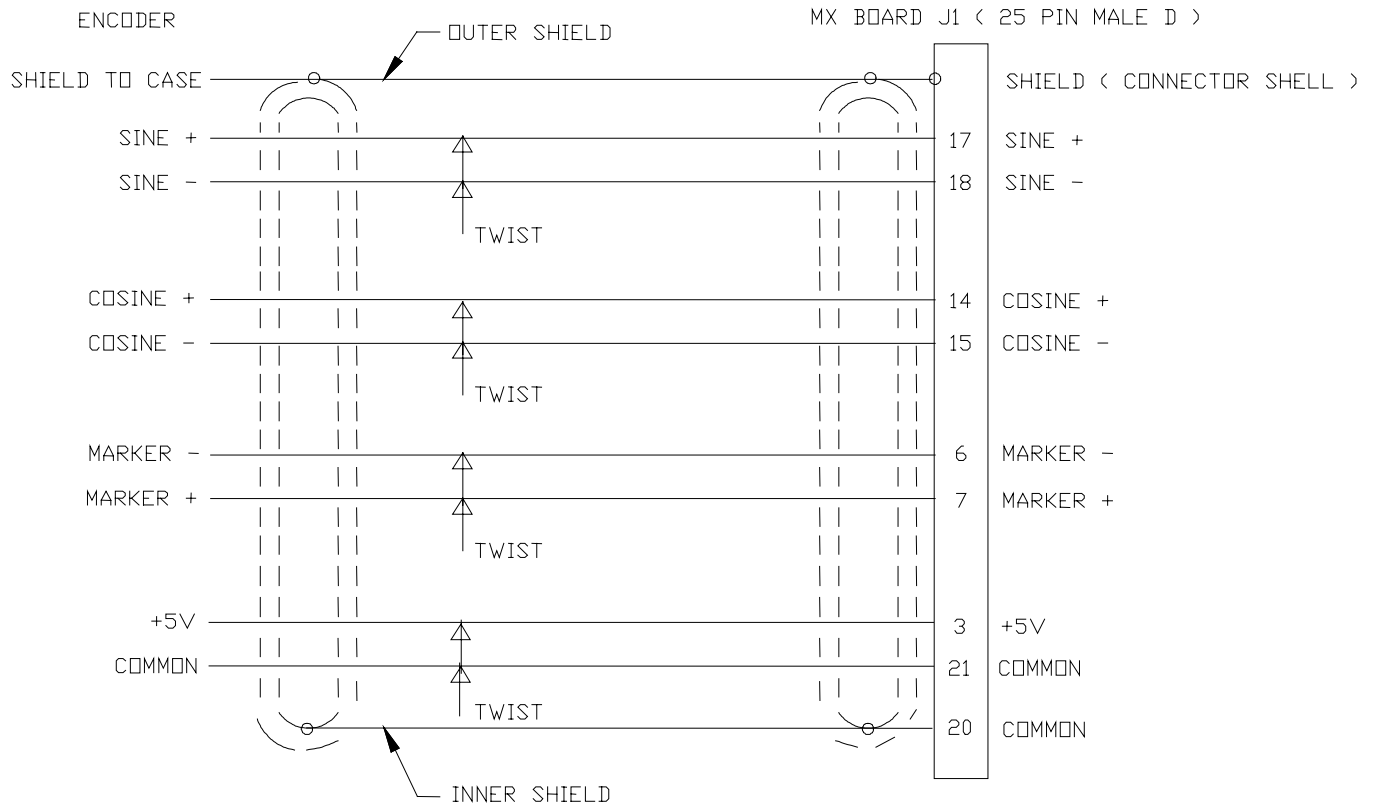

NOTE: MAXIMUM CABLE LENGTH IS 10 METERS
 TWISTED PAIRS ARE 1-4 TURNS / INCH

Figure 1-5. MX Encoder Cable Pinouts

1.4.6. Potentiometers

For the location of the pots on the MX multiplier board, refer to Figure 1-4.

Table 1-4. MX Multiplier Board Potentiometers

Pot	Function
R14	Phase adjust between sine and cosine signals
R15	Balance for encoder cosine signal
R16	Gain adjust for encoder cosine signal
R17	Balance for encoder sine signal
R18	Gain adjust for encoder sine signal

1.4.7. The RCN Resistor Network

The components of the RCN resistor network are determined by the type of input signals generated by the encoder. Figure 1-5 shows the configuration of the headers for common input signal types.

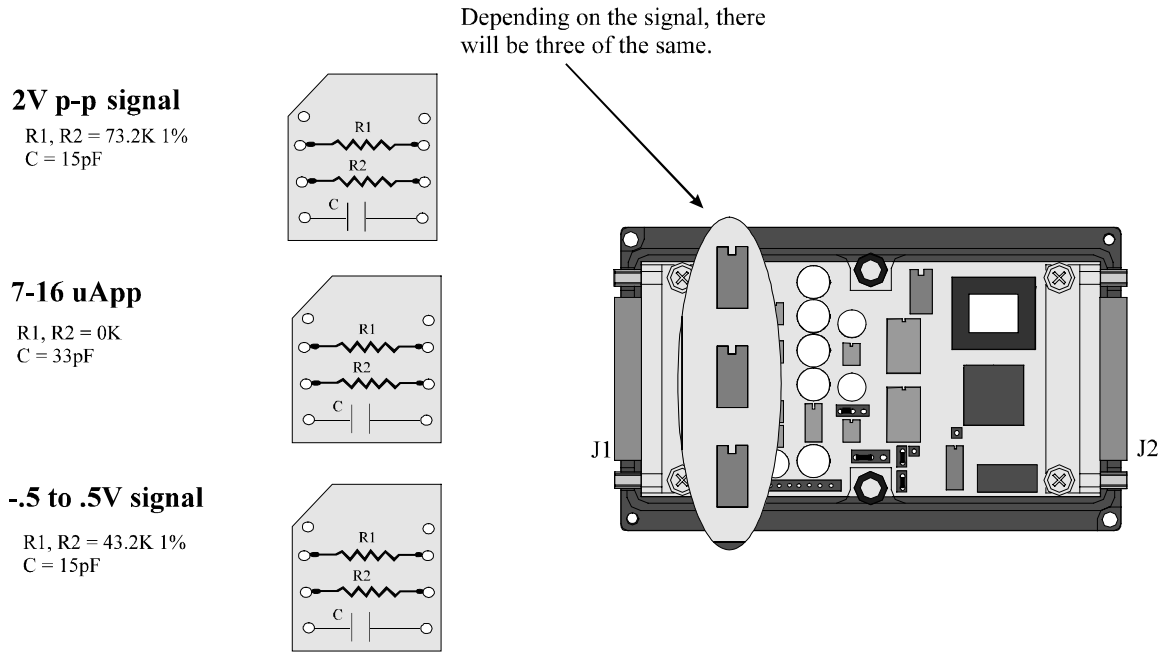

Figure 1-6. RCN Resistor Network

1.5. Output Pulse Clock Speed

The output sine and cosine pulse trains are interpolated to spread out the pulses evenly throughout the 1 μs sample period. The output pulse can be clocked at four different frequencies depending on the input frequency and the pulse width jumper settings. The output clock can be 4 MHz, 8 MHz, or 16 MHz. The following chart in Figure 1-6 shows the count spacing over a 1 μs period with the clock set to 16 MHz.

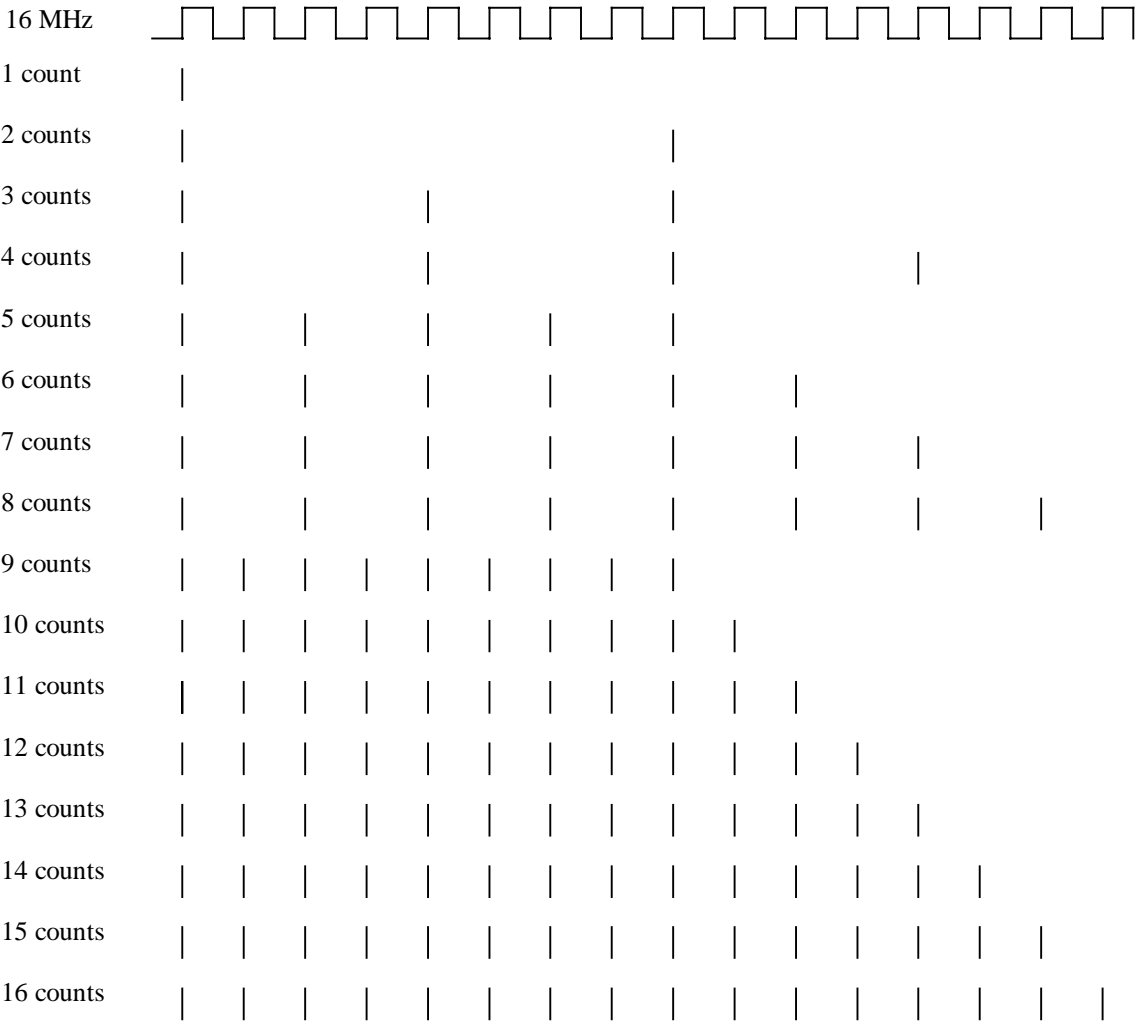

Figure 1-7. Count Spacing

1.6. MX Multiplier Board Specifications

The specifications for the MX multiplier board models are shown in Table 1-5.

Table 1-5. MX Multiplier Board Models and Specifications

Model	Interpolation	Clock Freq. (MHz)	Maximum input freq. (KHz)	Minimum edge separation	Minimum pulse width (μ s)	Power Supply
MX5	x5	16	500	.0625 μ s	.0625	5V \pm 5% (180 mA)
		8	400	.125 μ s	.125	5V \pm 5% (180 mA)
		4	200	.25 μ s	.25	5V \pm 5% (180 mA)
		2	100	.5 μ s	.5	5V \pm 5% (180 mA)
MX10	x10	16	400	.0625 μ s	.0625	5V \pm 5% (180 mA)
		8	200	.125 μ s	.125	5V \pm 5% (180 mA)
		4	100	.25 μ s	.25	5V \pm 5% (180 mA)
		2	50	.5 μ s	.5	5V \pm 5% (180 mA)
MX25	x25	16	160	.0625 μ s	.0625	5V \pm 5% (180 mA)
		8	80	.125 μ s	.125	5V \pm 5% (180 mA)
		4	40	.25 μ s	.25	5V \pm 5% (180 mA)
		2	20	.5 μ s	.5	5V \pm 5% (180 mA)
MX50	x50	16	80	.0625 μ s	.0625	5V \pm 5% (180 mA)
		8	40	.125 μ s	.125	5V \pm 5% (180 mA)
		4	20	.25 μ s	.25	5V \pm 5% (180 mA)
		2	10	.5 μ s	.5	5V \pm 5% (180 mA)

1.7. Physical Dimensions

Figure 1-8 illustrates the dimensions of the MX multiplier.

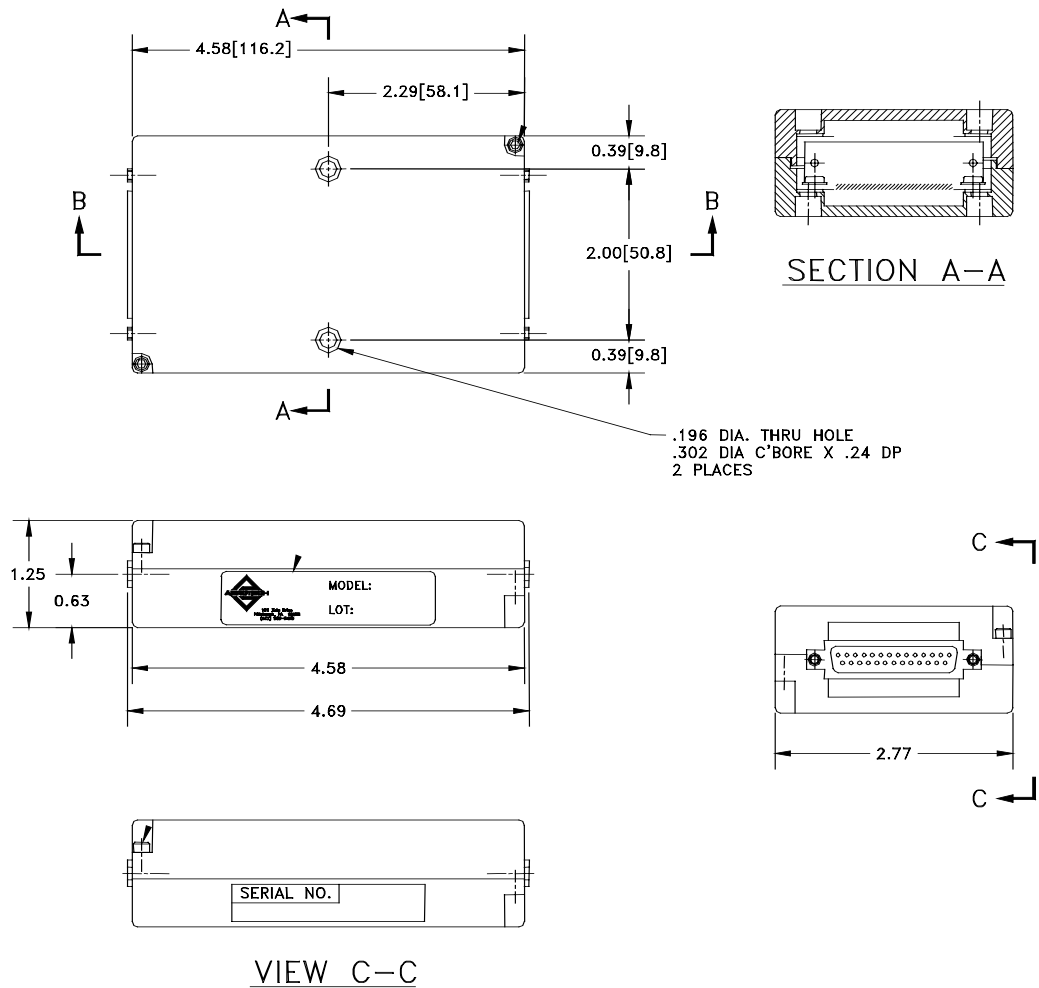

Figure 1-8. MX Multiplier Dimensions

1.8. Part Number and Ordering Information

The multiplication factor desired and input signal generated by the encoder will determine what MX multiplier board and resistor network to order. Table 1-6 provides information regarding part numbers for ordering the correct MX multiplier board and resistor network.

Table 1-6. MX Multiplier Board and Resistor Network Part Numbers

Series	Multiplication Factor	Resistor Network
MX	05	A - Input signal 2Vpp
	10	B - Input signal 7-16 μ App
	25	C - Input signal -.5 to .5V
	50	

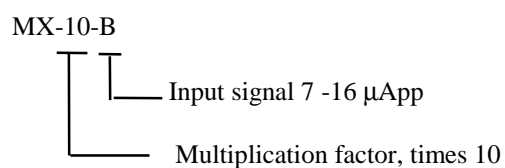
EXAMPLE:

▽ ▽ ▽

APPENDIX A: WARRANTY AND FIELD SERVICE**In This Section:**

- Laser Product Warranty
- Return Products Procedure
- Returned Product Warranty Determination
- Returned Product Non-warranty Determination
- Rush Service
- On-site Warranty Repair
- On-site Non-warranty Repair

Aerotech, Inc. warrants its products to be free from defects caused by faulty materials or poor workmanship for a minimum period of one year from date of shipment from Aerotech. Aerotech's liability is limited to replacing, repairing or issuing credit, at its option, for any products which are returned by the original purchaser during the warranty period. Aerotech makes no warranty that its products are fit for the use or purpose to which they may be put by the buyer, where or not such use or purpose has been disclosed to Aerotech in specifications or drawings previously or subsequently provided, or whether or not Aerotech's products are specifically designed and/or manufactured for buyer's use or purpose. Aerotech's liability or any claim for loss or damage arising out of the sale, resale or use of any of its products shall in no event exceed the selling price of the unit.

Aerotech, Inc. warrants its laser products to the original purchaser for a minimum period of one year from date of shipment. This warranty covers defects in workmanship and material and is voided for all laser power supplies, plasma tubes and laser systems subject to electrical or physical abuse, tampering (such as opening the housing or removal of the serial tag) or improper operation as determined by Aerotech. This warranty is also voided for failure to comply with Aerotech's return procedures.

Laser Products

Claims for shipment damage (evident or concealed) must be filed with the carrier by the buyer. Aerotech must be notified within (30) days of shipment of incorrect materials. No product may be returned, whether in warranty or out of warranty, without first obtaining approval from Aerotech. No credit will be given nor repairs made for products returned without such approval. Any returned product(s) must be accompanied by a return authorization number. The return authorization number may be obtained by calling an Aerotech service center. Products must be returned, prepaid, to an Aerotech service center (no C.O.D. or Collect Freight accepted). The status of any product returned later than (30) days after the issuance of a return authorization number will be subject to review.

Return Procedure

After Aerotech's examination, warranty or out-of-warranty status will be determined. If upon Aerotech's examination a warranted defect exists, then the product(s) will be repaired at no charge and shipped, prepaid, back to the buyer. If the buyer desires an air freight return, the product(s) will be shipped collect. Warranty repairs do not extend the original warranty period.

***Returned Product
Warranty Determination***

Returned Product Non-warranty Determination

After Aerotech's examination, the buyer shall be notified of the repair cost. At such time the buyer must issue a valid purchase order to cover the cost of the repair and freight, or authorize the product(s) to be shipped back as is, at the buyer's expense. Failure to obtain a purchase order number or approval within (30) days of notification will result in the product(s) being returned as is, at the buyer's expense. Repair work is warranted for (90) days from date of shipment. Replacement components are warranted for one year from date of shipment.

Rush Service

At times, the buyer may desire to expedite a repair. Regardless of warranty or out-of-warranty status, the buyer must issue a valid purchase order to cover the added rush service cost. Rush service is subject to Aerotech's approval.

On-site Warranty Repair

If an Aerotech product cannot be made functional by telephone assistance or by sending and having the customer install replacement parts, and cannot be returned to the Aerotech service center for repair, and if Aerotech determines the problem could be warranty-related, then the following policy applies:

Aerotech will provide an on-site field service representative in a reasonable amount of time, provided that the customer issues a valid purchase order to Aerotech covering all transportation and subsistence costs. For warranty field repairs, the customer will not be charged for the cost of labor and material. If service is rendered at times other than normal work periods, then special service rates apply.

If during the on-site repair it is determined the problem is not warranty related, then the terms and conditions stated in the following "On-Site Non-Warranty Repair" section apply.

On-site Non-warranty Repair

If any Aerotech product cannot be made functional by telephone assistance or purchased replacement parts, and cannot be returned to the Aerotech service center for repair, then the following field service policy applies:

Aerotech will provide an on-site field service representative in a reasonable amount of time, provided that the customer issues a valid purchase order to Aerotech covering all transportation and subsistence costs and the prevailing labor cost, including travel time, necessary to complete the repair.

Company Address

Aerotech, Inc.
101 Zeta Drive
Pittsburgh, PA 15238-2897
USA

Phone: (412) 963-7470
Fax: (412) 963-7459
TWX: (710) 795-3125



B

Board configuration, 1-1

C

Configuration
 System, 1-1
Connectors, 1-5
Count spacing, 1-9

H

Hardware configurations, 1-3

I

Introduction, 1-1

M

Marker pulse jumper, 1-3
Multiplication, 1-1
Multiplier signals, 1-2

O

Order information, 1-11
Output pulse
 clock speed, 1-8

P

Part numbers, 1-11
Physical dimensions, 1-11
Pinouts
 Connector, 1-6
Potentiometers, 1-7
Pots, 1-7

S

Signals, 1-2
Specifications, 1-10

T

Test points, 1-5

▽ ▽ ▽



READER'S COMMENTS

MX Multiplier Board Option Manual P/N EDO108, February 16, 2000

Please answer the questions below and add any suggestions for improving this document. Is the information:

	Yes	No
Adequate to the subject?	___	___
Well organized?	___	___
Clearly presented?	___	___
Well illustrated?	___	___
Would you like to see more illustrations?	___	___
Would you like to see more text?	___	___

How do you use this document in your job? Does it meet your needs?
What improvements, if any, would you like to see? Please be specific or cite examples.

Your name _____
Your title _____
Company name _____
Address _____

Remove this page from the document and fax or mail your comments to the technical writing department of Aerotech.

AEROTECH, INC.
Technical Writing Department
101 Zeta Drive
Pittsburgh, PA. 15238-2897 U.S.A.
Fax number (412) 963-7009

