

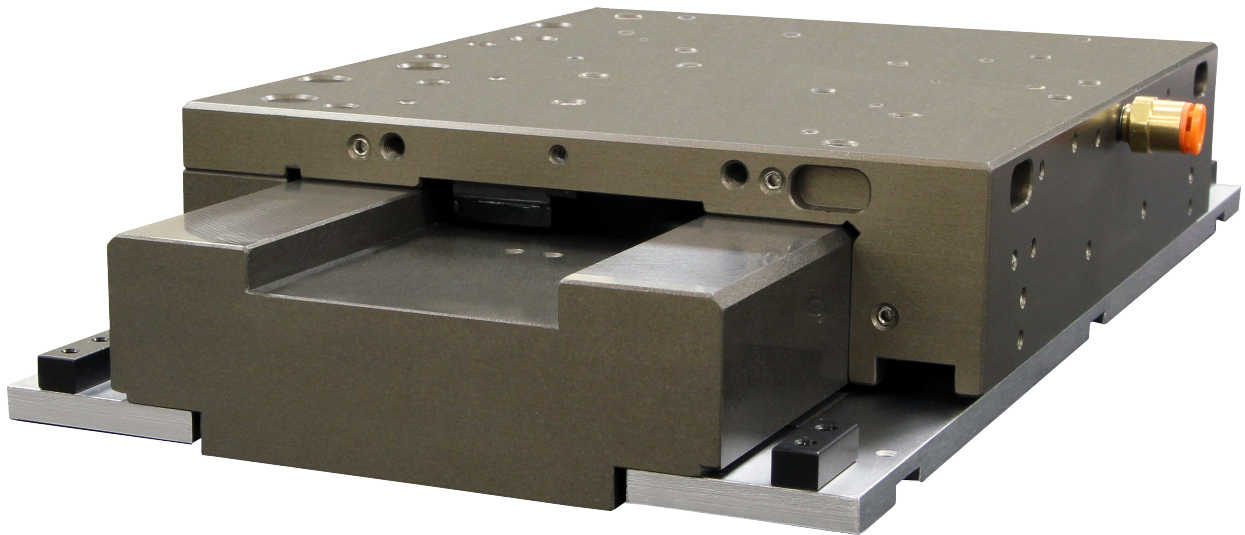

ABL1000WB Hardware Manual

Revision: 1.00.00



Global Technical Support

Go to www.aerotech.com/global-technical-support for information and support about your Aerotech, Inc. products. The website supplies software, product manuals, Help files, training schedules, and PC-to-PC remote technical support. If necessary, you can complete Product Return (RMA) forms and get information about repairs and spare or replacement parts. To get help immediately, contact a service office or your sales representative. Include your customer order number in your email or have it available before you call.

United States (World Headquarters)	
Email: Support@aerotech.com Phone: +1-412-967-6440 Fax: +1-412-967-6870	101 Zeta Drive Pittsburgh, PA 15238-2811 www.aerotech.com
United Kingdom	Japan
Email: Support@aerotech.com Phone: +44 (0)1256 855055 Fax: +44 (0)1256 855649	Email: Support@aerotech.com Phone: +81 (0)50 5830 6814 Fax: +81 (0)43 306 3773
Germany	China
Email: Support@aerotech.com Phone: +49 (0)911 967 9370 Fax: +49 (0)911 967 93720	Email: Support@aerotech.com Phone: +86 (21) 5508 6731
France	Taiwan
Email: Support@aerotech.com Phone: +33 2 37 21 87 65	Email: Support@aerotech.com Phone: +886 (0)2 8751 6690

This manual contains proprietary information and may not be reproduced, disclosed, or used in whole or in part without the express written permission of Aerotech, Inc. Product names mentioned herein are used for identification purposes only and may be trademarks of their respective companies.

Copyright © 2019, Aerotech, Inc., All rights reserved.

Aerotech Worldwide

United States ■ France ■ Germany ■ United Kingdom
China ■ Japan ■ Taiwan



Table of Contents

ABL1000WB Hardware Manual **1**

 Table of Contents 3

 List of Figures 4

 List of Tables 5

 Safety Procedures and Warnings 7

 EU Declaration of Incorporation 9

Chapter 1: Overview **11**

 1.1. Environmental Specifications 12

 1.2. Accuracy and Temperature Effects 12

 1.3. Basic Specifications 13

 1.4. Air Requirements 14

Chapter 2: Installation **15**

 2.1. Unpacking and Handling the Stage 15

 2.2. Dimensions 17

 2.3. Securing the Stage to the Mounting Surface 18

 2.4. Attaching the Payload to the Stage 20

 Load Capability 20

Chapter 3: Electrical Specifications and Installation **21**

 3.1. Motor and Feedback Connector 22

 3.2. Motor and Feedback Wiring 24

 3.3. Motor and Feedback Specifications 25

 3.4. Limits, Marker, and Machine Direction 27

 3.5. Motor and Feedback Phasing 28

Chapter 4: Maintenance **31**

 4.1. Service and Inspection Schedule 31

 4.2. Cleaning and Lubrication 31

 4.2.1. Cleaning Process 32

 4.3. Troubleshooting 33

Appendix A: Warranty and Field Service **35**

Appendix B: Revision History **37**

Index **39**

List of Figures

Figure 2-1: Shipping Clamps16

Figure 2-2: ABL1000WB Dimensions17

Figure 2-3: Surface Mounting Holes19

Figure 2-4: Payload and Multi-Axis Stage Mounting Holes20

Figure 3-1: Motor and Feedback Wiring24

Figure 3-2: Machine Direction27

Figure 3-3: Hall Phasing28

Figure 3-4: Analog Encoder Phasing Reference Diagram29

Figure 3-5: Encoder Phasing Reference Diagram (Standard)29

Figure 4-1: Air Bearing Surfaces Require Periodic Cleaning32

List of Tables

Table 1-1: Model Numbers and Ordering Options	11
Table 1-2: Environmental Specifications	12
Table 1-3: ABL1000WB Series Specifications	13
Table 1-4: Air Specifications	14
Table 3-1: Motor and Feedback Connector	23
Table 3-2: Feedback Specifications	25
Table 3-3: Encoder Specifications	25
Table 3-4: ABL1000WB Motor Specifications	26
Table 4-1: Recommended Cleaning Solvents	31

This page intentionally left blank.

Safety Procedures and Warnings

Read this manual in its entirety before installing, operating, or servicing this product. If you do not understand the information contained herein, contact an Aerotech representative before proceeding. Strictly adhere to the statements given in this section and other handling, use, and operational information given throughout the manual to avoid injury to you and damage to the equipment.

This manual tells you how to carefully and correctly use and operate the ABL1000WB. Read all parts of this manual before you install or operate the ABL1000WB or before you do maintenance to your system. To prevent injury to you and damage to the equipment, obey the precautions in this manual. The precautions that follow apply when you see a Danger or Warning symbol in this manual. If you do not obey these precautions, injury to you or damage to the equipment can occur. If you do not understand the information in this manual, contact Aerotech Global Technical Support. This product has been designed for light industrial manufacturing or laboratory environments. The protection provided by the equipment could be impaired if the product is used in a manner not specified by the manufacturer.



DANGER: This product contains potentially lethal voltages. To reduce the possibility of electrical shock, bodily injury, or death the following precautions must be followed.

1. Access to the ABL1000WB and component parts must be restricted while connected to a power source.
2. Do not connect or disconnect any electrical components or connecting cables while connected to a power source.
3. Disconnect electrical power before servicing equipment.
4. All components must be properly grounded in accordance with local electrical safety requirements.
5. Operator safeguarding requirements must be addressed during final integration of the product.
6. **PINCH POINT!** Keep Hands Clear while the stage is in motion.



WARNING: To minimize the possibility of electrical shock, bodily injury or death the following precautions must be followed.

1. Moving parts can cause crushing or shearing injuries. Access to all stage and motor parts must be restricted while connected to a power source.
2. Cables can pose a tripping hazard. Securely mount and position all system cables to avoid potential hazards.
3. Do not expose this product to environments or conditions outside of the listed specifications. Exceeding environmental or operating specifications can cause damage to the equipment.
4. The ABL1000WB must be mounted securely. Improper mounting can result in injury and damage to the equipment.
5. Use care when moving the ABL1000WB. Lifting or transporting the ABL1000WB improperly can result in injury or damage to the ABL1000WB.
6. This product is intended for light industrial manufacturing or laboratory use. Use of this product for unintended applications can result in injury and damage to the equipment.
7. If the product is used in a manner not specified by the manufacturer, the protection provided by the product can be impaired and result in damage, shock, injury, or death.
8. The stage forcer temperature may exceed 75°C.
9. Operators must be trained before operating this equipment.
10. All service and maintenance must be performed by qualified personnel.
11. Eye protection must be worn when in the proximity of compressed air components.

This page intentionally left blank.

EU Declaration of Incorporation

Manufacturer: Aerotech, Inc.
101 Zeta Drive
Pittsburgh, PA 15238-2811
USA

herewith declares that the product:

ABL1000WB Stage

is intended to be incorporated into machinery to constitute machinery covered by the Directive 2006/42/EC as amended; and that the following harmonized European standards have been applied:

EN ISO 12100:2010	Safety of machinery - Basic concepts, general principles for design
EN 60204-1:2010	Safety of machinery - Electrical equipment of machines - Part 1: General requirements

and further more declares that

it is not allowed to put the equipment into service until the machinery into which it is to be incorporated or of which it is to be a component has been found and declared to be in conformity with the provisions of the Directive 2006/42/EC and with national implementing legislation, i.e., as a whole, including the equipment referred to in this Declaration.

This is to certify that the aforementioned product is in accordance with the applicable requirements of the following Directive(s):

2011/65/EU	RoHS 2 Directive
------------	------------------

Authorized Representative: Simon Smith, European Director
Address: Aerotech Ltd
The Old Brick Kiln, Ramsdell, Tadley
Hampshire RG26 5PR
UK

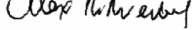
Name	 / Alex Weibel
Position	Engineer Verifying Compliance
Location	Pittsburgh, PA
Date	3/19/2019



This page intentionally left blank.

Chapter 1: Overview

NOTE: Aerotech continually improves its product offerings; listed options may be superseded at any time. All drawings and illustrations are for reference only and were complete and accurate as of this manual's release. Refer to www.aerotech.com for the most up-to-date information.

Table 1-1: Model Numbers and Ordering Options

ABL1000WB Series Linear Air-Bearing Stage	
Travel (Required)	
-050	50 mm travel
-100	100 mm travel
-150	150 mm travel
Feedback (Required)	
-E1	Incremental linear encoder, 1 Vpp amplified sine output
-E2	High-accuracy incremental linear encoder, 1 Vpp amplified sine output
Cable Management (Optional)	
-CMS1	Cable management system for single axis
-CMS2	Cable management system for lower (X) axis of XY assembly
-CMS3	Cable management system for upper (Y) axis of XY assembly
Metrology (Optional)	
-PL1	Metrology, uncalibrated with performance plots
-PL2	Metrology, calibrated (HALAR) with performance plots
Accessories (to be ordered as separate line item)	
ABF	Air-bearing filtration kit

1.1. Environmental Specifications



WARNING: Do not expose this product to environments or conditions outside of the listed specifications. Exceeding environmental or operating specifications can cause damage to the equipment.

Table 1-2: Environmental Specifications

Ambient Temperature	Operating: 16° to 25° C (61° to 77° F) The optimal operating temperature is 20° C ±2° C (68° F ±4° F). If at any time the operating temperature deviates from 20° C degradation in performance could occur.
	Storage: 0° to 40° C (32° to 104° F) in original shipping packaging
Humidity	Operating: 40 percent to 60 percent RH The optimal operating humidity is 50 percent RH.
	Storage: 30 percent to 60 percent RH, non-condensing in original packaging
Altitude	Operating: 0 m to 2,000 m (0 ft to 6,562 ft) above sea level Contact Aerotech if your specific application involves use above 2,000 m or below sea level.
Vibration	Use the system in a low vibration environment. Excessive floor or acoustical vibration can affect system performance. Contact Aerotech for information regarding your specific application.
Protection Rating	ABL1000WB stages are not suited for dusty or wet environments. This equates to an ingress protection rating of IP00.
Use	Indoor use only

1.2. Accuracy and Temperature Effects

Due to the small clearances in the air bearing design, extreme temperature environments could cause a decrease in performance or permanent damage to the stage. Standard Aerotech air-bearing stages are designed for and built in a 20°C (68°F) environment. The environmental temperature must be controlled to within 0.25°C per 24 hours to ensure that the ABL1000WB specifications are repeatable over an extended period of time. The severity of temperature effects on all specifications depends on many different environmental conditions, including how the ABL1000WB is mounted. Contact the factory for more details.

1.3. Basic Specifications

Table 1-3: ABL1000WB Series Specifications

Model		ABL1000WB-050	ABL1000WB-100	ABL1000WB-150
Travel		50 mm	100 mm	150 mm
Drive System		Linear Brushless Servomotor		
Resolution	-E1	2.5 nm		
	-E2	0.5 nm		
Maximum Travel Speed ⁽¹⁾		300 mm/s		
Maximum Linear Acceleration		1 g - 10m/s ² (no load)		
Maximum Horizontal Load ⁽²⁾		15.0 kg		
Accuracy ⁽¹⁾	-E1	±0.3 µm ⁽³⁾ ±2 µm	±0.3 µm ⁽³⁾ ±2 µm	±0.3 µm ⁽³⁾ ±5 µm
	-E2	±0.2 µm ⁽³⁾ ±1 µm	±0.2 µm ⁽³⁾ ±1 µm	±0.2 µm ⁽³⁾ ±2 µm
Repeatability	-E1	±50 nm; ±100 nm		
	-E2	±50 nm ⁽¹⁾		
Straightness and Flatness ⁽⁴⁾		±0.25 µm	±0.25 µm	±0.4 µm
Pitch and Yaw		±0.25 arc sec	±0.50 arc sec	±1.0 arc sec
Nominal Stage Weight		9.7 kg	10.7 kg	11.6 kg
Moving Mass		4.3 kg		
Operating Pressure ⁽⁶⁾		80 psi ±5 psi		
Air Consumption ⁽⁶⁾⁽⁷⁾		13.2 SLPM		
Construction		Aluminum Body/Hardcoat		
<p>(1) Maximum speed based on stage capability; maximum application velocity may be limited by system data rate and system resolution.</p> <p>(2) Max load for XY configuration is 10.0 kg.</p> <p>(3) Values with Aerotech controls and -PL2 metrology option.</p> <p>(4) Dependent on flatness of stage mounting surface.</p> <p>(5) To protect air bearing against under-pressure, an in-line pressure switch tied to the motion controller/amplifier E-Stop is recommended.</p> <p>(6) Air supply must be clean, dry to 0° F dew point and filtered to 0.25 µm or better. Recommend nitrogen at 99.9% purity.</p> <p>(7) Maximum expected air consumption for single axis.</p> <p>NOTE: Specifications are for single-axis systems measured 25 mm above the tabletop; performance of multi-axis system is payload and workpoint dependent. Consult the Aerotech factory for multi-axis or non-standard applications.</p>				

1.4. Air Requirements

The quality of the air that you supply to the stage is important to the operation of the stage. Aerotech recommends that you connect the air supply to the air inlet with a polyurethane air hose.

Table 1-4: Air Specifications

		Description
Air Quality	Nitrogen ⁽¹⁾	<ul style="list-style-type: none"> 99.99% pure filtered⁽²⁾ to 0.25 microns
	Compressed Air	<ul style="list-style-type: none"> filtered⁽²⁾ to 0.25 microns dry to 0° F dew point oil free
Operating Air Pressure		80 psi ± 5 psi (517 to 551 kPa)
Air Consumption		13.2 SLPM
Air Inlet Fitting ⁽³⁾		1/16" ID x 1/8" OD x 25 ft length hose
(1) Recommended		
(2) The filtration requirement is to prevent particles from clogging the air bearing openings.		
(3) Aerotech recommends using a polyurethane air hose.		

Aerotech also recommends that you install a pressure switch (P/N: MCA03094) tied to the motion controller's emergency stop (ESTOP) that will remove power to the air bearing if pressure drops below 40 psi (a drop in pressure could result in contact between bearing surfaces which could cause damage to the surfaces). For easier air-supply setup, you can purchase pneumatic kits and filter/filter-dryer kits from Aerotech. Aerotech's ABF Air Filtration Unit incorporates air filtration plus a pressure monitoring switch.

Chapter 2: Installation



WARNING: ABL1000WB installation must be in accordance to instructions provided by this manual and any accompanying documentation. Failure to follow these instructions could result in injury or damage to the equipment.

2.1. Unpacking and Handling the Stage



WARNING: It is the customer's responsibility to safely and carefully lift the stage.

- Make sure that all moving parts are secure before moving the ABL1000WB. Unsecured moving parts may shift and cause bodily injury.
- Improper handling could adversely affect the performance of the ABL1000WB. Use care when moving the ABL1000WB.

NOTE: If any damage has occurred during shipping, report it immediately.

Carefully remove the ABL1000WB from its protective shipping container. Gently set the ABL1000WB on a smooth, flat, and clean surface.

Before operating the ABL1000WB, it is important to let it stabilize at room temperature for at least 12 hours. Allowing it to stabilize to room temperature will ensure that all of the alignments, preloads, and tolerances are the same as they were when tested at Aerotech. Use compressed nitrogen or clean, dry, oil-less air to remove any dust or debris that has collected during shipping.

Each ABL1000WB has a label listing the system part number and serial number. These numbers contain information necessary for maintaining or updating system hardware and software. Locate this label and record the information for later reference.

Shipping Clamps

Red, anodized aluminum shipping brackets have been installed to prevent unwanted motion and potential damage from occurring during shipment (see [Figure 2-1](#)). The brackets must be removed before the ABL1000WB can be operated. Retain the brackets and hardware for future use.



WARNING: Do not attempt to move the carriage (or table top) of the ABL1000WB until the shipping brackets have been removed. Moving the carriage with the shipping brackets installed can cause permanent damage to the ABL1000WB.

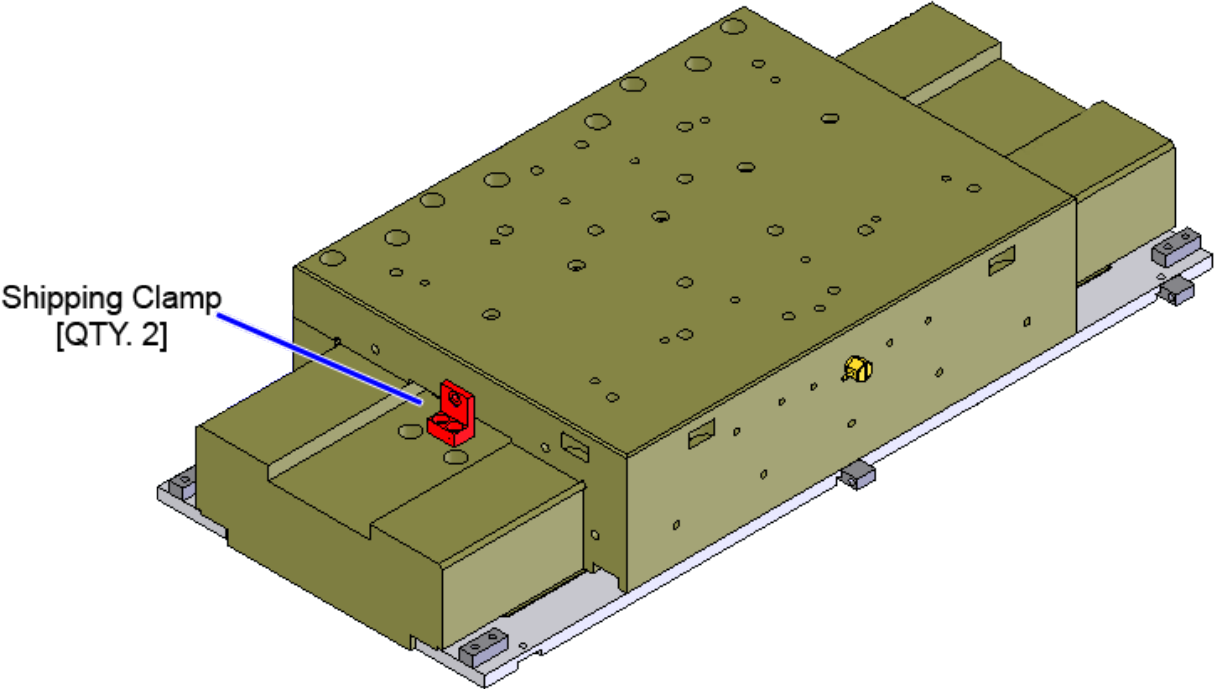
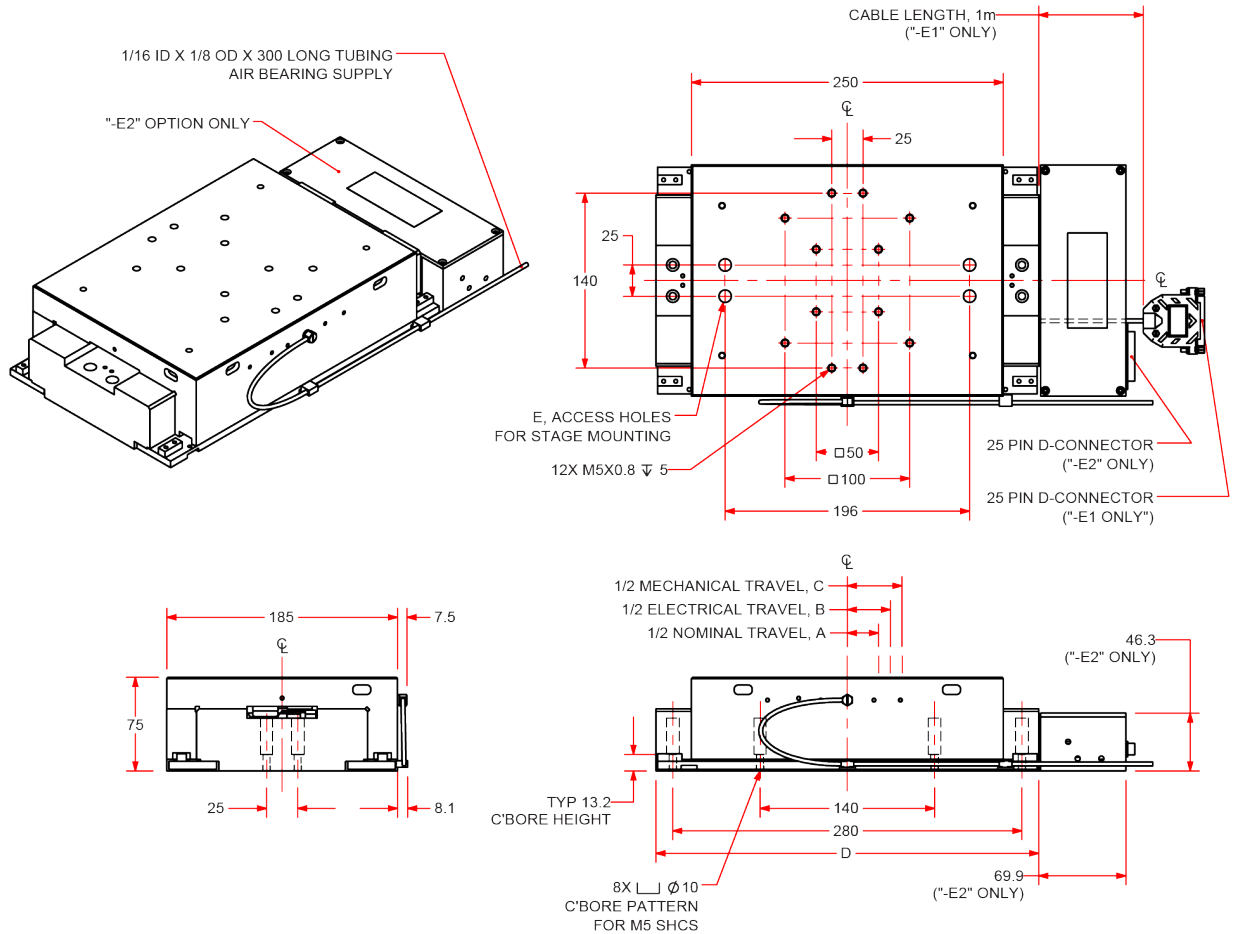

Figure 2-1: Shipping Clamps

NOTE: After removing the shipping brackets, retain them for future use. Do not transport or ship the ABL1000WB without the shipping brackets attached.

2.2. Dimensions



STAGE SHOWN AT MID TRAVEL

MODEL	TOTAL TRAVEL	A 1/2 NOMINAL TRAVEL	B 1/2 ELECTRICAL TRAVEL	C 1/2 MECHANICAL TRAVEL	D STAGE BASE LENGTH	E STAGE MOUNTING ACCESS HOLES
ABL1000WB-050	50	25.0	25.7	28.4	307	4X ϕ 10 THRU
ABL1000WB-100	100	50.0	50.7	53.4	357	4X ϕ 10 THRU
ABL1000WB-150	150	75.0	75.7	78.4	407	-

DIMENSIONS: MILLIMETERS

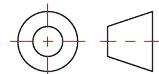

Figure 2-2: ABL1000WB Dimensions

2.3. Securing the Stage to the Mounting Surface

The mounting surface must be flat and have adequate stiffness in order to achieve the maximum performance from the ABL1000WB stage. When it is mounted to a non-flat surface, the stage can be distorted as the mounting screws are tightened. This distortion will decrease overall accuracy. Adjustments to the mounting surface must be done before the stage is secured.



WARNING: Make sure that all moving parts are secure before moving the ABL1000WB. Unsecured moving parts may shift and cause bodily injury.



DANGER: Strong rare-earth magnets are present in the linear motor magnet track. Loose metal objects (tools, watches, keys, etc.) may cause personal injury and/or damage to the equipment.



WARNING: The ABL1000WB must be mounted securely. Improper mounting can result in injury and damage to the equipment.

NOTE: To maintain accuracy, the mounting surface must be flat to within 1 μm per 50 mm. 3 μm per 50 mm.

NOTE: The stage base is precision machined and verified for flatness prior to stage assembly at the factory. If machining is required to achieve the desired flatness, it should be performed on the mounting surface rather than the stage base. Shimming should be avoided if possible. If shimming is required, it should be minimized to improve the rigidity of the system.

Procedure to mount the ABL1000WB:



WARNING: Do not attempt to move the carriage of the ABL1000WB until the air supply, detailed in [Section 1.4.](#), has been installed. Moving the stage table without air supplied can cause permanent damage to the stage.

1. Supply air to the stage with the air inlet. Refer to [Section 1.4.](#) for more information on air supply.
2. Manually move the stage to one end of travel to show additional mounting holes. See [Figure 2-3.](#)
3. Mount the stage to the base with M5 screws. The number of mounting holes depends on stage travel.
4. After half of the mounting screws are installed, move the stage to the opposite end of travel to access the remaining screws. Repeat the installation process for these holes.

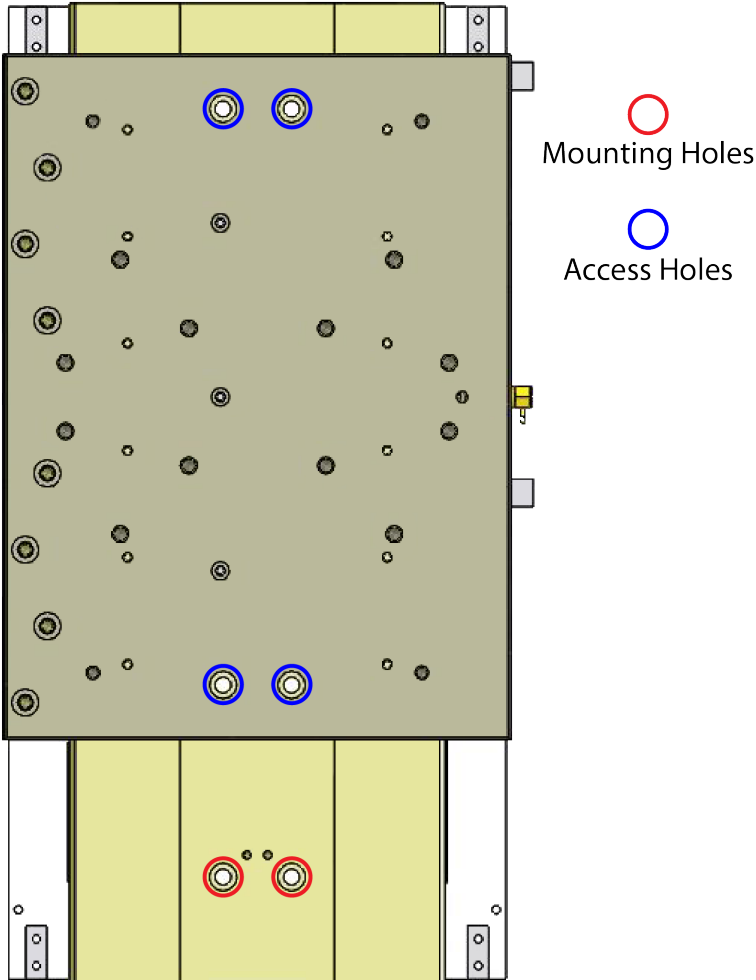

Figure 2-3: Surface Mounting Holes

2.4. Attaching the Payload to the Stage

To prevent damage to the payload or stage, test the operation of the stage before the payload is attached. Aerotech recommends that customers use a representative payload during start-up to prevent accidental damage to the stage and the payload. Proceed with the electrical installation and test the motion control system in accordance with the system documentation. Document all results for future reference. For information on electrical installation refer to [Chapter 3](#) and the documentation delivered with the stage.

NOTE: If your ABL1000WB was purchased with Aerotech controls, it might have been tuned with a representative payload based on the information provided at the time of order. If the ABL1000WB is started up without a payload, the servo gains provided by Aerotech with the shipment may not be appropriate and servo instability can occur. Refer to the controller help file for tuning assistance.

The payload must be flat, rigid, and comparable to the stage in quality to maintain optimum performance.

NOTE: For valid system performance, the mounting interface should be flat within 1 μm per 25 mm.

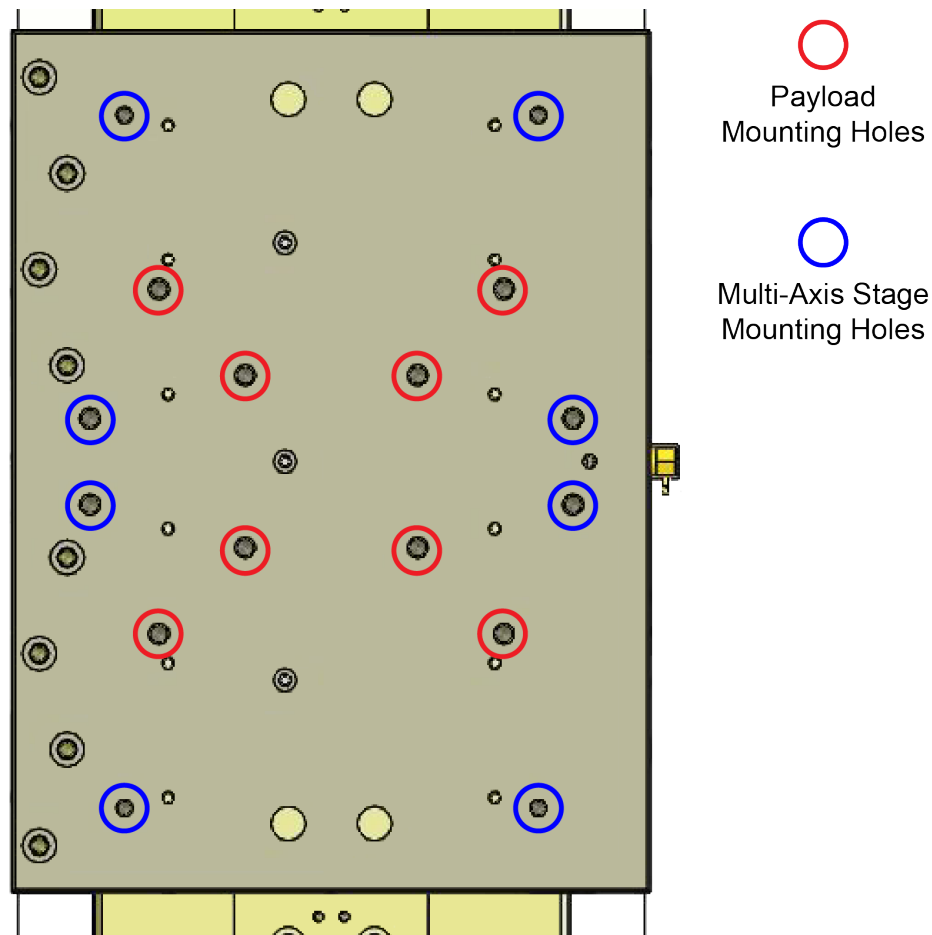

Figure 2-4: Payload and Multi-Axis Stage Mounting Holes

Load Capability

Applied loads should be symmetrically distributed whenever possible (i.e., the payload should be centered on the stage table and the entire stage should be centered on the support structure).

Chapter 3: Electrical Specifications and Installation



WARNING: Electrical installation must be performed by properly qualified personnel.

Aerotech motion control systems are adjusted at the factory for optimum performance. When the ABL1000WB is part of a complete Aerotech motion control system, setup usually involves connecting the ABL1000WB to the appropriate drive chassis with the cables provided. Labels on the system components usually indicate the appropriate connections.

If system level integration was purchased, an electrical drawing showing system interconnects has been supplied with the system (separate from this documentation).

The electrical wiring from the motor and encoder are integrated at the factory. Refer to the sections that follow for standard motor wiring and connector pinouts.

The stage and its carriage are protected from dangerous faults by an integral safety ground through the stage's motor power cable.



WARNING: Applications requiring access to the stage while it is energized will require additional grounding and safeguards. The System Integrator or qualified installer is responsible for determining and meeting all safety and compliance requirements necessary for the integration of this stage into the final application.



DANGER: Remove power before connecting or disconnecting electrical components or cables. Failure to do so may cause electric shock or damage to the equipment.



WARNING: Operator access to the base and tabletop must be restricted while connected to a power source. Failure to do so may cause electric shock.

3.1. Motor and Feedback Connector

Stages equipped with standard motors and encoders come from the factory completely wired and assembled.

NOTE: Refer to the other documentation accompanying your Aerotech equipment. Call your Aerotech representative if there are any questions on system configuration.

The protective ground connection of the ABL1000WB provides motor frame ground protection only. Additional grounding and safety precautions are required for applications requiring access to the stage while it is energized. The System Integrator or qualified installer is responsible for determining and meeting all safety and compliance requirements necessary for the integration of this stage into the final application.



DANGER: Remove power before connecting or disconnecting electrical components or cables. Failure to do so may cause electric shock or damage to the equipment.



WARNING: The protective ground connection must be properly installed to minimize the possibility of electric shock.



WARNING: Operator access to the base and tabletop must be restricted while connected to a power source. Failure to do so may cause electric shock.



CAUTION: The stage controller must provide over-current and over-speed protection. Failure to do so may result in permanent damage to the motor and stage components.

Table 3-1: Motor and Feedback Connector

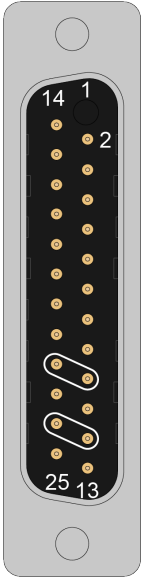
Pin	Description	Connector
1	Connector key (to prevent improper connection)	
2	Cosine-N	
3	Sine-N	
4	Marker-N	
5	Common	
6	Common	
7	CCW/-LMT	
8	Hall Effect sensor, phase A	
9	Hall Effect sensor, phase C	
10	Frame ground	
11	Motor Phase A (internally connected to Pin 23)	
12	Motor Phase B (internally connected to Pin 24)	
13	Motor Phase C (internally connected to Pin 25)	
14	Cosine	
15	Sine	
16	Marker	
17	+5VDC (Encoder, Halls, and Limits)	
18	Reserved	
19	CW/+LMT	
20	Reserved	
21	Hall Effect sensor, phase B	
22	Frame ground	
23	Motor Phase A (internally connected to Pin 11)	
24	Motor Phase B (internally connected to Pin 12)	
25	Motor Phase C (internally connected to Pin 13)	

Mating Connector	Aerotech P/N	Third Party P/N
Backshell	ECK00656	Amphenol #17E-1726-2
Connector	ECK00300	FCI DB25S064TLF

3.2. Motor and Feedback Wiring

All motor and controller manufacturers have their own designations for motor phases A/B/C and Hall signals A/B/C (refer to Section 3.5. for motor phasing). Shielded cables are required for the motor and feedback connections.

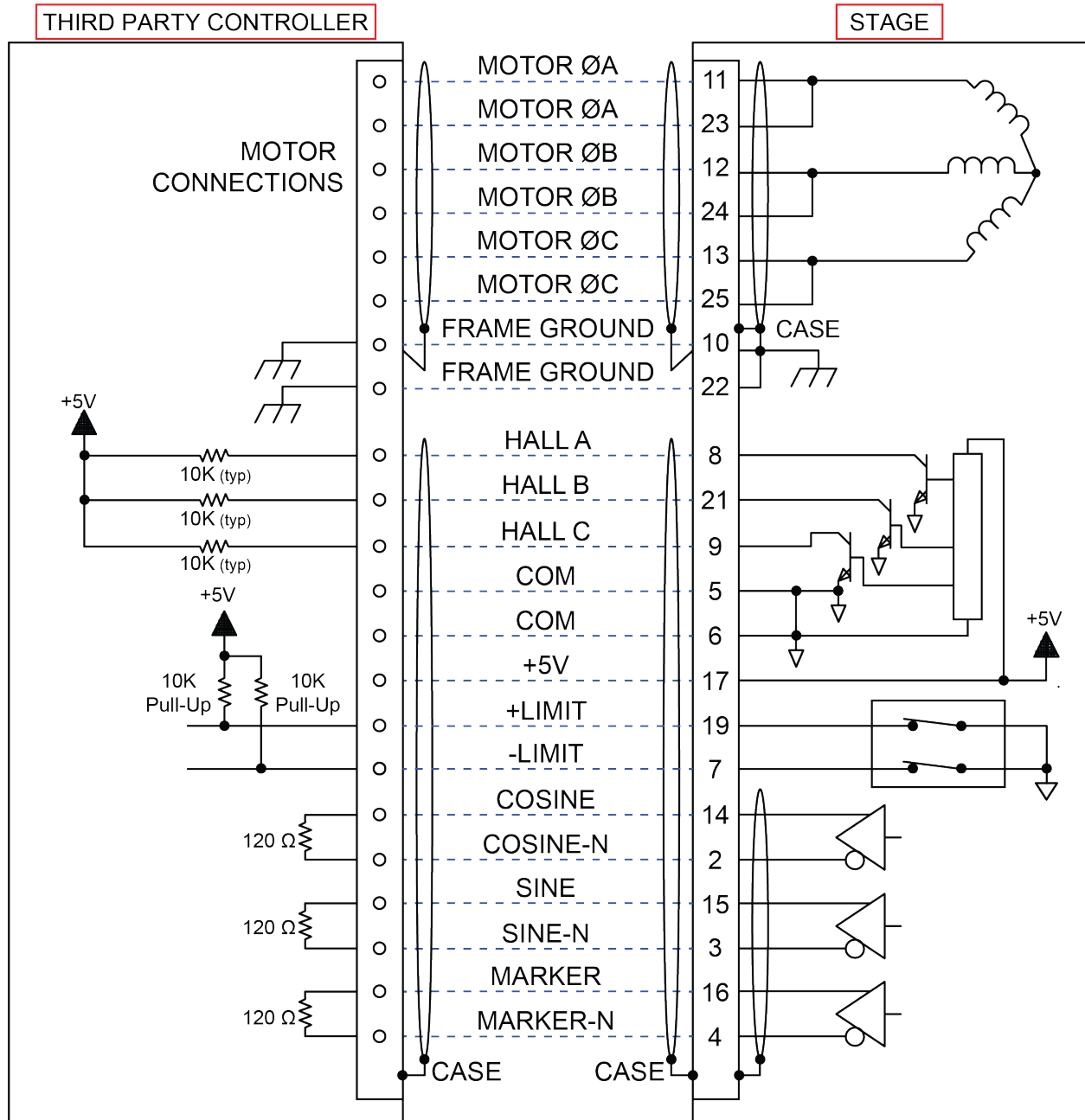

Figure 3-1: Motor and Feedback Wiring

3.3. Motor and Feedback Specifications

Table 3-2: Feedback Specifications

Hall-Effect Sensors Specifications	
Supply Voltage	5 V \pm 5% ⁽¹⁾
Supply Current	50 mA
Output Type	Open Collector
Output Voltage	24 V max (pull up)
Output Current	5 mA (sinking)

Encoder Specifications	
Supply Voltage	5 V \pm 5% ⁽¹⁾
Supply Current	<130 mA for E1; <165 mA for E2
Output Signals	Sinusoidal Type (Incremental Encoder): 1 V _{pk-pk} into 120 Ω Load (differential signals SIN+, SIN-, COS+, COS- are .5 V _{pk-pk} relative to ground.)

Limit Switch Specifications	
Supply Voltage	5 V \pm 5% ⁽¹⁾
Supply Current	25 mA (typical)
Output Type	Open Collector
Output Voltage	5 V
Output Current	10 mA max (sinking)
Output Polarity	Normally Closed (NC) <ul style="list-style-type: none"> • Sinks current to ground (Logic "0") when not in limit • High impedance (Logic "1") when in limit • Requires external pull-up to +5 V (10 kΩ recommended)

1. Halls, encoder, and limits are interconnected to a common 5VDC supply (see [Table 3-1](#)).

Note: If the ABL1000WB is driven beyond the electrical limit, it will encounter a mechanical stop. Impacting the mechanical stop could cause damage to the stage even at low speeds.

Table 3-3: Encoder Specifications

Model	Fundamental Signal Period	Digital Resolution
-E1	20 μ m	--
-E1 with x4000 Interpolation		5 nm
-E1 with x16000 Interpolation		1.25 nm
-E2	4 μ m	--
-E2 with x4000 Interpolation		1 nm
-E2 with x16000 Interpolation		0.25 nm

NOTE: Quadrature decoding included in interpolated resolution calculations

Table 3-4: ABL1000WB Motor Specifications

		ABL1000 Motor
Performance Specifications (1)(2)		
Continuous Force, No Forced Cooling(2)	N (lb)	9.7 (2.18)
Peak Force(3)	N (lb)	38.7 (8.7)
Electrical Specifications(2)		
Winding Designation	A / B	-A
BEMF Constant (line-line, max)	V/(m/s) (V/(in/s))	3.78 (0.096)
Continuous Current	A_{pk} (A_{rms})	2.94 (2.08)
Peak Current, Stall(3)	A_{pk} (A_{rms})	11.76 (8.31)
Force Constant, Sine Drive(4)(5)	N/A_{pk} (lb/ A_{pk})	3.29 (0.74)
	N/A_{rms} (lb/ A_{rms})	2.33 (0.52)
Motor Constant (4)(6)	N/\sqrt{W} (lb/ \sqrt{W})	1.41 (0.317)
Resistance, 25°C (line-line)	Ω	5.2
Inductance (line-line)	mH	0.7
Thermal Resistance, No Forced Cooling	°C/W	2.22
Maximum Bus Voltage(7)	V_{DC}	80
Magnetic Pole Pitch	mm (in)	16.0 (0.63)
1. Performance is dependent upon heat sink configuration, system cooling conditions, and ambient temperature 2. All performance and electrical specifications $\pm 10\%$ 3. Peak force assumes correct rms current; consult Aerotech. 4. Force constant and motor constant specified at stall 5. All Aerotech amplifiers are rated A_{pk} ; use force constant in $N \cdot m/A_{pk}$ when sizing. 6. Values shown @ 100°C rise above a 25°C ambient temperature, with motor mounted to the specified aluminum heat sink. 7. Bus voltage limitation is due to stage cabling, not the motor.		

3.4. Limits, Marker, and Machine Direction

Aerotech stages are configured to have positive and negative "machine" directions. The machine direction defines the phasing of the feedback and motor signals and is dictated by the stage wiring (refer to [Section 3.5](#) for Motor and Feedback phasing information). Programming direction of a stage is set by the controller that is used to move the stage. The galvo motors for each axis have internal electrical limits for both positive and negative machine direction motion. Programming direction is typically selectable in the controller, while machine direction is hardwired in the stage. [Figure 3-2](#) shows the machine direction of ABL1000WB stages.

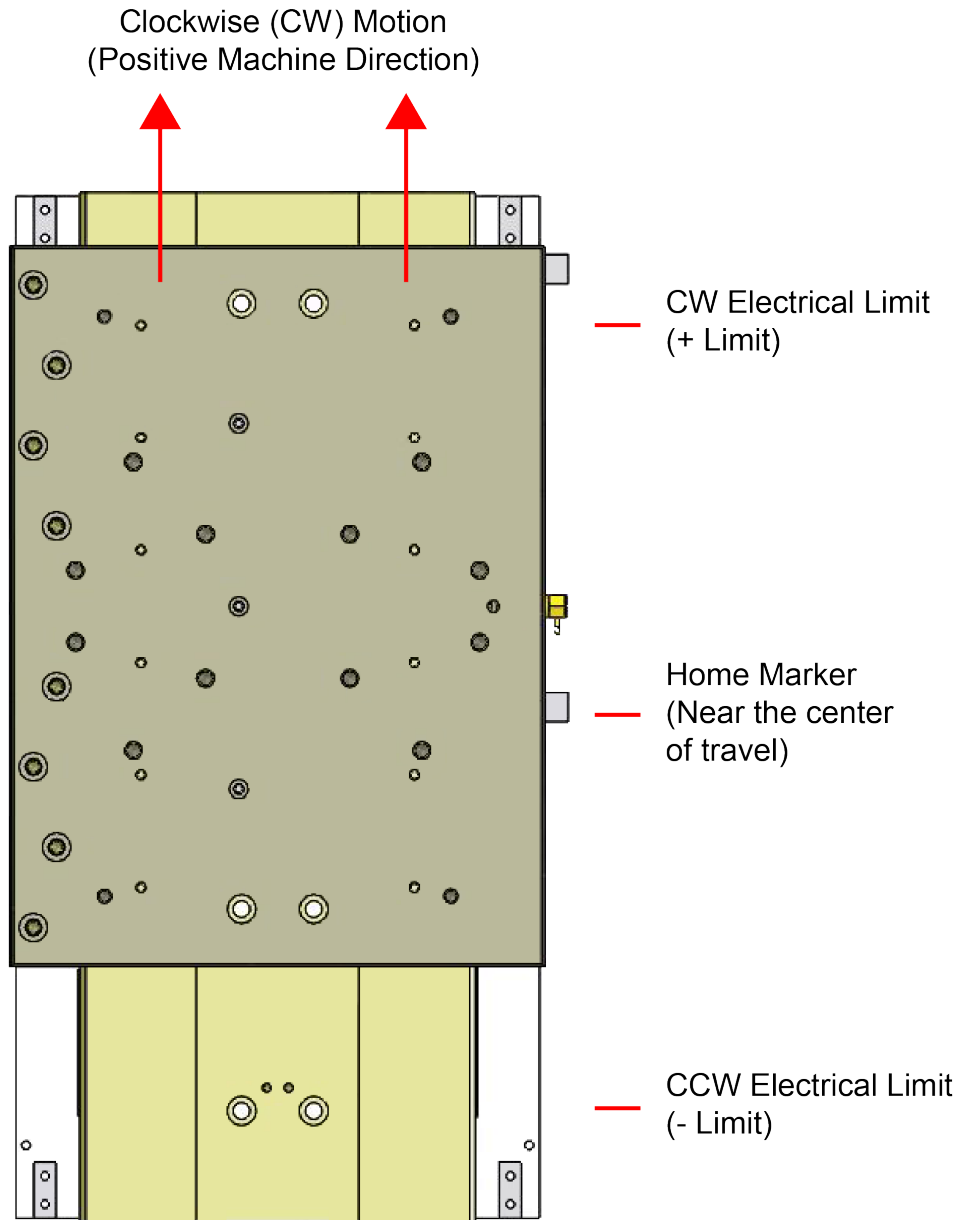

Figure 3-2: Machine Direction

3.5. Motor and Feedback Phasing

Motor phase voltage is measured relative to the virtual wye common point.

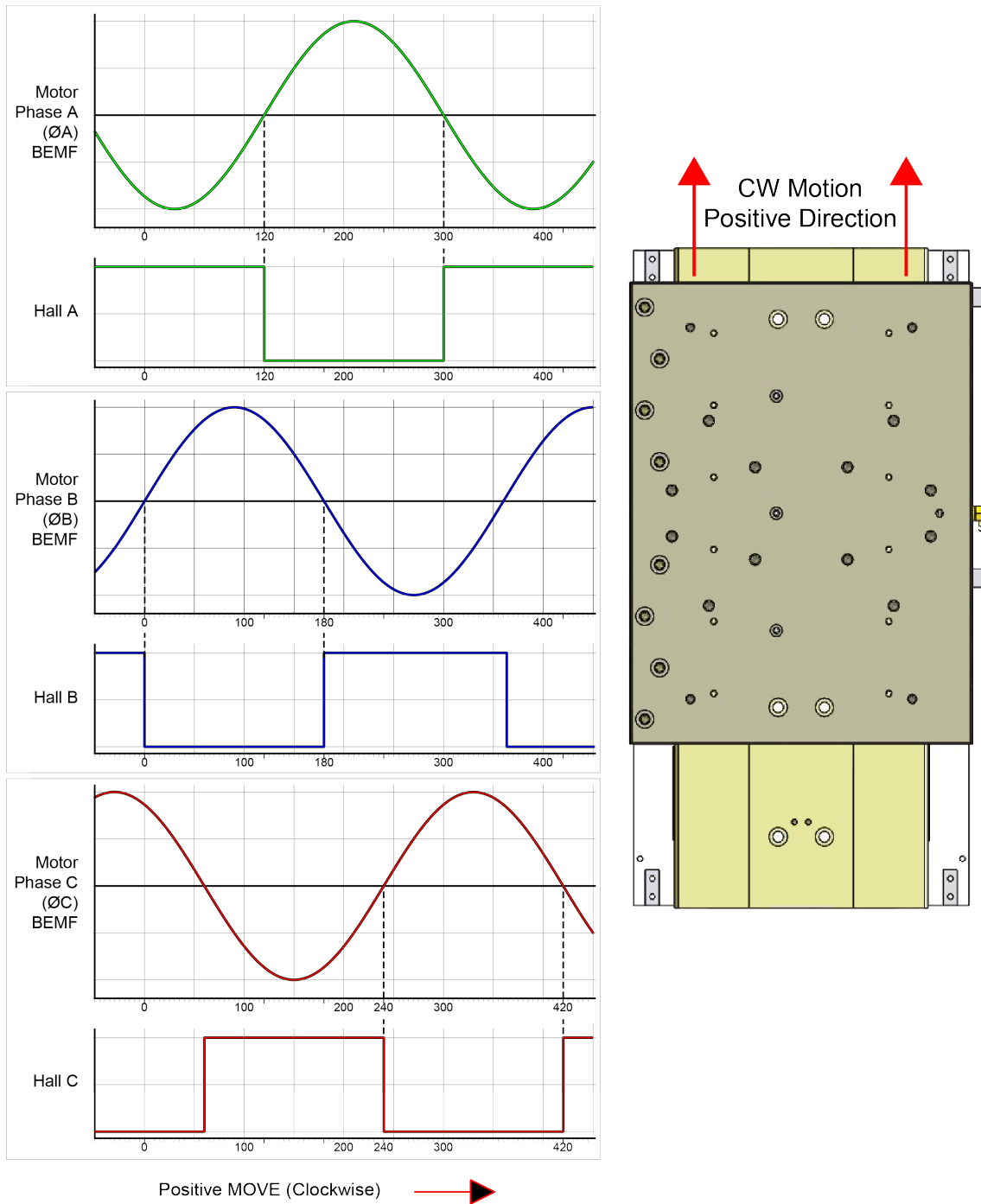

Figure 3-3: Hall Phasing

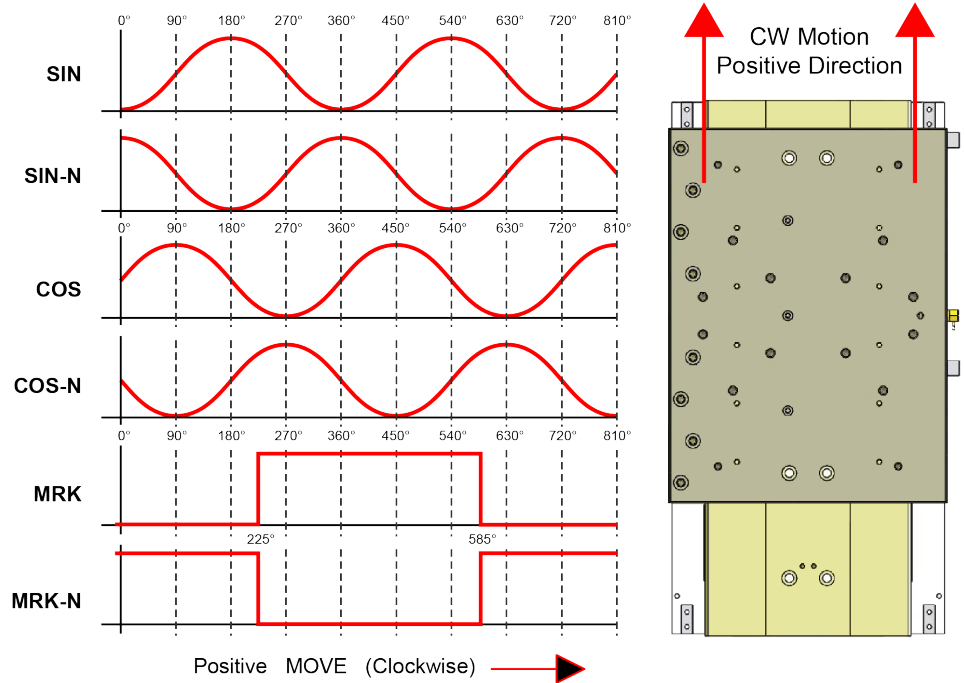

Figure 3-4: Analog Encoder Phasing Reference Diagram

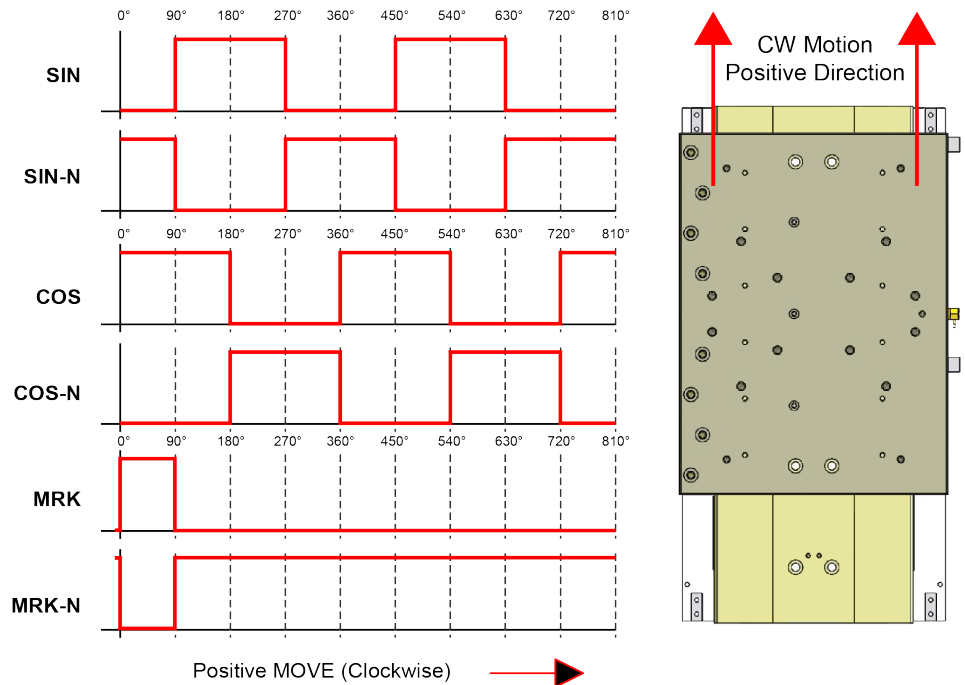

Figure 3-5: Encoder Phasing Reference Diagram (Standard)

This page intentionally left blank.

Chapter 4: Maintenance

The ABL1000WB series stages are designed to require minimum maintenance. Due to the non-contact air bearing design, there are no friction surfaces or dynamic seals to wear or require lubrication. However, it is important to clean the bearing surfaces and encoder strips to maintain the accuracy of the stage. This chapter will detail the cleaning and lubrication process and specify recommended cleaning solvents.

NOTE: The bearing area must be kept free of foreign matter and moisture; otherwise, the performance and life expectancy of the stage will be reduced.



DANGER: To minimize the possibility of bodily injury or death, disconnect all electrical power prior to performing any maintenance or making adjustments to the equipment.

4.1. Service and Inspection Schedule

Inspect the ABL1000WB at least once per month. A longer or shorter inspection interval may be required depending on the specific application, and conditions such as the duty cycle, speed, and environment.

Monthly inspections should include but not be limited to:

- Visually inspect the stage and cables.
- Re-tighten loose connectors.
- Replace or repair damaged cables.
- Clean the ABL1000WB and any components and cables as needed.
- Repair any damage before operating the ABL1000WB.
- Inspect and perform an operational check on all safeguards and protective devices.

4.2. Cleaning and Lubrication

Clean all air-bearing surfaces and encoder scales to prevent damage to the stage or decreased performance. Prevent dust build-up from accumulating in the linear motors, encoders, and air-bearing surfaces by blowing clean, dry, compressed air over the entire stage. Due to the non-contact design, these surfaces operate very close together, allowing dust to buildup and cause damage.

All encoder surfaces and magnet tracks should be cleaned with isopropyl alcohol. Aluminum hard-coated metal surface may be cleaned with isopropyl alcohol or acetone. Acetone should not be used on magnet tracks because it could break down the epoxy that holds the magnets in place.

Table 4-1: Recommended Cleaning Solvents

Item	Recommended Cleaner
Encoders, Magnets	Isopropyl Alcohol
Hard-Coated Aluminum	Acetone
Granite	Surface plate cleaner ⁽¹⁾
1. Surface plate cleaner is available from precision granite manufacturers.	

4.2.1. Cleaning Process

To clean all of the air bearing surfaces and encoder scales, it is necessary to move the stage.



DANGER: Strong rare-earth magnets are present in the linear motor magnet track. Loose metal objects (tools, watches, keys, etc.) may cause personal injury and/or damage to the equipment.



WARNING: Do not attempt to move the carriage of the ABL1000WB until the air supply, detailed in [Section 1.4.](#), has been installed. Moving the stage table without air supplied can cause permanent damage to the stage.

1. Blow off the stage with clean, dry, compressed air, and remove any visible debris on the outside of the stage. Move the stage to one end of travel and remove power.



DANGER: To minimize the possibility of bodily injury or death, disconnect all electrical power prior to performing any maintenance or making adjustments to the equipment.

2. Clean all of the surfaces that you can access. Make sure to use the correct solvent on each surface (refer to [Section 4.2.](#)). When the surface is fully dry, move the stage by hand to the opposite end of travel.



WARNING: Make sure that all solvent has completely evaporated before attempting to move the stage. Even the slightest amount of solvent could cause damage to the air bearing surfaces, clog the air ducts, or damage the electronics of the stage.

3. This should expose all previously covered surfaces. Repeat the cleaning process. Restore power to the stage after all solvents are fully dry.

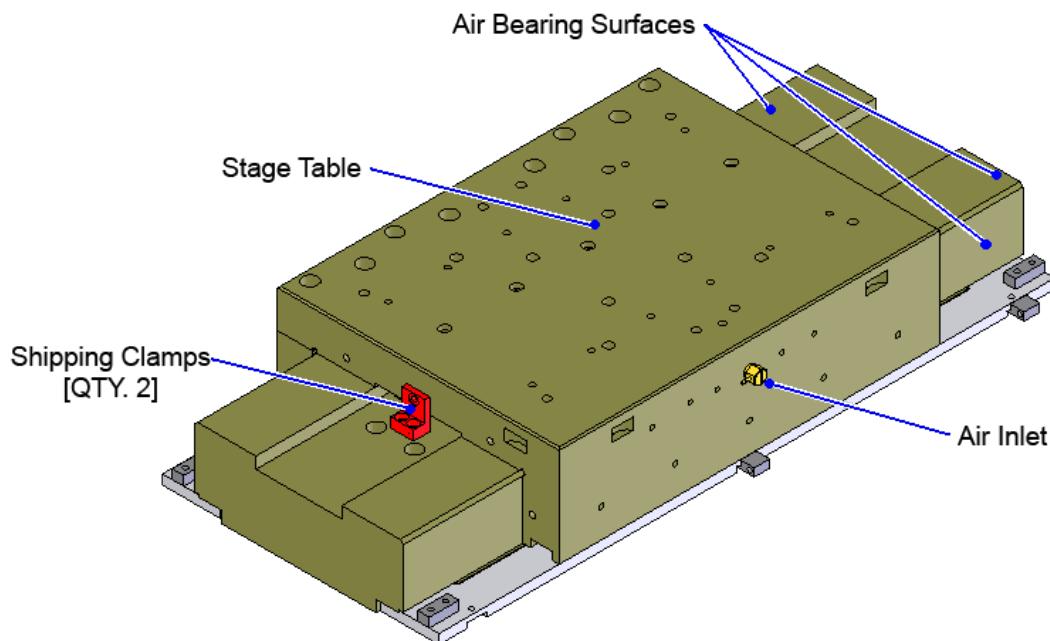

Figure 4-1: Air Bearing Surfaces Require Periodic Cleaning

4.3. Troubleshooting

Symptom	Possible Cause and Solution
Stage will not move	<ul style="list-style-type: none"> • Shipping restraints still installed. Remove the red anodized shipping brackets. • In Limit condition. Check limits (refer to) and refer to the Controller documentation for polarity and compatibility requirements (Example: voltage requirements). • Controller trap or fault (refer to the Controller documentation). • Emergency stop fault. The system is configured to operate with an air pressure safety switch, and either the air pressure is too low or the switch is not present. Check the air supply and the switch. Air pressure switches are typically configured to trip if the supply pressure to the bearing drops below 40 psi.
Stage moves uncontrollably	<ul style="list-style-type: none"> • Encoder (sine and cosine) signal connections (refer to and Controller documentation). • Motor Connections (refer to and the Controller documentation).
Stage oscillates or squeals	<ul style="list-style-type: none"> • Gains misadjusted (refer to the Controller documentation). • Encoder signals (refer to the Controller documentation).

This page intentionally left blank.

Appendix A: Warranty and Field Service

Aerotech, Inc. warrants its products to be free from harmful defects caused by faulty materials or poor workmanship for a minimum period of one year from date of shipment from Aerotech. Aerotech's liability is limited to replacing, repairing or issuing credit, at its option, for any products that are returned by the original purchaser during the warranty period. Aerotech makes no warranty that its products are fit for the use or purpose to which they may be put by the buyer, whether or not such use or purpose has been disclosed to Aerotech in specifications or drawings previously or subsequently provided, or whether or not Aerotech's products are specifically designed and/or manufactured for buyer's use or purpose. Aerotech's liability on any claim for loss or damage arising out of the sale, resale, or use of any of its products shall in no event exceed the selling price of the unit.

THE EXPRESS WARRANTY SET FORTH HEREIN IS IN LIEU OF AND EXCLUDES ALL OTHER WARRANTIES, EXPRESSED OR IMPLIED, BY OPERATION OF LAW OR OTHERWISE. IN NO EVENT SHALL AEROTECH BE LIABLE FOR CONSEQUENTIAL OR SPECIAL DAMAGES.

Return Products Procedure

Claims for shipment damage (evident or concealed) must be filed with the carrier by the buyer. Aerotech must be notified within thirty (30) days of shipment of incorrect material. No product may be returned, whether in warranty or out of warranty, without first obtaining approval from Aerotech. No credit will be given nor repairs made for products returned without such approval. A "Return Materials Authorization (RMA)" number must accompany any returned product(s). The RMA number may be obtained by calling an Aerotech service center or by submitting the appropriate request available on our website (www.aerotech.com). Products must be returned, prepaid, to an Aerotech service center (no C.O.D. or Collect Freight accepted). The status of any product returned later than thirty (30) days after the issuance of a return authorization number will be subject to review.

Visit <https://www.aerotech.com/global-technical-support.aspx> for the location of your nearest Aerotech Service center.

Returned Product Warranty Determination

After Aerotech's examination, warranty or out-of-warranty status will be determined. If upon Aerotech's examination a warranted defect exists, then the product(s) will be repaired at no charge and shipped, prepaid, back to the buyer. If the buyer desires an expedited method of return, the product(s) will be shipped collect. Warranty repairs do not extend the original warranty period.

Fixed Fee Repairs - Products having fixed-fee pricing will require a valid purchase order or credit card particulars before any service work can begin.

All Other Repairs - After Aerotech's evaluation, the buyer shall be notified of the repair cost. At such time the buyer must issue a valid purchase order to cover the cost of the repair and freight, or authorize the product(s) to be shipped back as is, at the buyer's expense. Failure to obtain a purchase order number or approval within thirty (30) days of notification will result in the product(s) being returned as is, at the buyer's expense.

Repair work is warranted for ninety (90) days from date of shipment. Replacement components are warranted for one year from date of shipment.

Rush Service

At times, the buyer may desire to expedite a repair. Regardless of warranty or out-of-warranty status, the buyer must issue a valid purchase order to cover the added rush service cost. Rush service is subject to Aerotech's approval.

On-site Warranty Repair

If an Aerotech product cannot be made functional by telephone assistance or by sending and having the customer install replacement parts, and cannot be returned to the Aerotech service center for repair, and if Aerotech determines the problem could be warranty-related, then the following policy applies:

Aerotech will provide an on-site Field Service Representative in a reasonable amount of time, provided that the customer issues a valid purchase order to Aerotech covering all transportation and subsistence costs. For warranty field repairs, the customer will not be charged for the cost of labor and material. If service is rendered at times other than normal work periods, then special rates apply.

If during the on-site repair it is determined the problem is not warranty related, then the terms and conditions stated in the following "On-Site Non-Warranty Repair" section apply.

On-site Non-Warranty Repair

If any Aerotech product cannot be made functional by telephone assistance or purchased replacement parts, and cannot be returned to the Aerotech service center for repair, then the following field service policy applies:

Aerotech will provide an on-site Field Service Representative in a reasonable amount of time, provided that the customer issues a valid purchase order to Aerotech covering all transportation and subsistence costs and the prevailing labor cost, including travel time, necessary to complete the repair.

Service Locations

<http://www.aerotech.com/contact-sales.aspx?mapState=showMap>

USA, CANADA, MEXICO Aerotech, Inc. Global Headquarters Phone: +1-412-967-6440 Fax: +1-412-967-6870	CHINA Aerotech China Full-Service Subsidiary Phone: +86 (21) 5508 6731	GERMANY Aerotech Germany Full-Service Subsidiary Phone: +49 (0)911 967 9370 Fax: +49 (0)911 967 93720
JAPAN Aerotech Japan Full-Service Subsidiary Phone: +81 (0)50 5830 6814 Fax: +81 (0)43 306 3773	TAIWAN Aerotech Taiwan Full-Service Subsidiary Phone: +886 (0)2 8751 6690	UNITED KINGDOM Aerotech United Kingdom Full-Service Subsidiary Phone: +44 (0)1256 855055 Fax: +44 (0)1256 855649

Have your customer order number ready before calling.

Appendix B: Revision History

Revision	General Information
1.00.00	New Manual

This page intentionally left blank.

Index

		Limit Switch Specifications	25
	2	Lubrication	31
2010			
	A	M	
Acetone		MCA03094	14
air hose		mounting surface	
Air Requirements		securing stage	18
Alcohol		P	
Altitude		part number	15
Ambient Temperature		pressure switch	14
Attaching the Payload		Protection Rating	12
	C	protective ground connection	22
Cleaning		S	
Cleaning Solvents		Securing the Stage to the Mounting Surface	18
	D	serial number	15
Dimensions		Shipping Clamps	15
drop in pressure		Solvents	31
	E	Specifications	13
EN 60204-1		stabilizing stage	15
EN ISO 12100		stage	
Encoder Specifications		distortion	18
	G	stabilizing	15
Global Technical Support		Support	2
	H	T	
Hall-Effect Sensors Specifications		Technical Support	2
hose, air		testing stage operation	20
Humidity		V	
	I	Vibration	12
Inspection Schedule		W	
Isopropyl Alcohol		Warranty and Field Service	35
	L		
label			

This page intentionally left blank.