



# HexGen<sup>®</sup> HEX500-350HL Hexapod Hardware Manual

Revision: 1.01.00



## Global Technical Support

Go to [www.aerotech.com/global-technical-support](http://www.aerotech.com/global-technical-support) for information and support about your Aerotech products. The website provides downloadable resources (such as up-to-date software, product manuals, and Help files), training schedules, and PC-to-PC remote technical support. You can also complete Product Return (RMA) forms and get information about repairs and spare or replacement parts. For immediate help, contact a service office or your sales representative. Have your customer order number available before you call or include it in your email.

United States (World Headquarters)	
Phone: +1-412-967-6440 Fax: +1-412-967-6870 Email: <a href="mailto:service@aerotech.com">service@aerotech.com</a>	101 Zeta Drive Pittsburgh, PA 15238-2811 <a href="http://www.aerotech.com">www.aerotech.com</a>
United Kingdom	Japan
Phone: +44 (0)1256 855055 Fax: +44 (0)1256 855649 Email: <a href="mailto:service@aerotech.co.uk">service@aerotech.co.uk</a>	Phone: +81 (0)50 5830 6814 Fax: +81 (0)43 306 3773 Email: <a href="mailto:service@aerotechkk.co.jp">service@aerotechkk.co.jp</a>
Germany	China
Phone: +49 (0)911 967 9370 Fax: +49 (0)911 967 93720 Email: <a href="mailto:service@aerotechgmbh.de">service@aerotechgmbh.de</a>	Phone: +86 (21) 5508 6731 Email: <a href="mailto:service@aerotech.com">service@aerotech.com</a>
France	Taiwan
Phone: +33 2 37 21 87 65 Email: <a href="mailto:service@aerotech.co.uk">service@aerotech.co.uk</a>	Phone: +886 (0)2 8751 6690 Email: <a href="mailto:service@aerotech.tw">service@aerotech.tw</a>

This manual contains proprietary information and may not be reproduced, disclosed, or used in whole or in part without the express written permission of Aerotech, Inc. Product names mentioned herein are used for identification purposes only and may be trademarks of their respective companies.

Copyright © 2016-2018, Aerotech, Inc., All rights reserved.

Aerotech Worldwide

United States ■ France ■ Germany ■ United Kingdom  
China ■ Japan ■ Taiwan



**Table of Contents**

- HexGen® HEX500-350HL Hexapod Hardware Manual ..... 1**
  - Table of Contents ..... 3
  - List of Figures ..... 4
  - List of Tables ..... 5
  - Safety Procedures and Warnings ..... 7
  - EU Declaration of Incorporation ..... 9
  
- Chapter 1: Overview ..... 11**
  - 1.1. Environmental Specifications ..... 12
    - 1.1.1. Accuracy and Temperature Effects ..... 12
  - 1.2. Basic Specifications ..... 13
  - 1.3. Understanding Basic HEX500-350HL Operation ..... 14
    - 1.3.1. Hexapod Axes ..... 14
    - 1.3.2. Strut Limits and Hexapod Range ..... 15
    - 1.3.3. Homing ..... 15
  
- Chapter 2: Mechanical Specifications and Installation ..... 17**
  - 2.1. Unpacking and Handling the Hexapod ..... 17
  - 2.2. Dimensions ..... 19
  - 2.3. Securing the HEX500-350HL to the Mounting Surface ..... 20
  - 2.4. Attaching the Payload to the HEX500-350HL ..... 22
  
- Chapter 3: Electrical Specifications and Installation ..... 25**
  - 3.1. Motor and Feedback Connectors ..... 26
  - 3.2. Motor and Feedback Wiring ..... 29
  - 3.3. Motor and Feedback Specifications ..... 31
  - 3.4. Machine Direction ..... 33
  - 3.5. Motor and Feedback Phasing ..... 34
  
- Chapter 4: Maintenance ..... 37**
  - 4.1. Service and Inspection Schedule ..... 37
  - 4.2. Cleaning and Lubrication ..... 38
  - 4.3. Troubleshooting ..... 39
  
- Appendix A: Warranty and Field Service ..... 41**
- Appendix B: Revision History ..... 43**
- Index ..... 45**

**List of Figures**

Figure 1-1: HEX500-350HL Callouts .....11

Figure 1-2: Axis Orientation .....14

Figure 2-1: Lifting and Shipping Brackets .....18

Figure 2-2: HEX500-350HL Dimensions .....19

Figure 2-3: Mounting Hole Locations .....21

Figure 2-4: HEX500-350HL Vertical Load Capabilities .....22

Figure 2-5: HEX500-350HL Horizontal Load Capabilities .....23

Figure 2-6: HEX500-350HL Inverted Load Capabilities .....23

Figure 3-1: Motor and Feedback Wiring (-E2 Connector) .....29

Figure 3-2: Motor and Feedback Wiring (-E3 Connector) .....30

Figure 3-3: Machine Direction .....33

Figure 3-4: Hall Phasing .....34

Figure 3-5: Encoder Phasing Reference Diagram (Standard) .....35

**List of Tables**

Table 1-1: Model Options ..... 11

Table 1-2: Environmental Specifications ..... 12

Table 1-3: HEX500-350HL Series Specifications ..... 13

Table 2-1: Stage to Mounting Surface Hardware ..... 21

Table 3-1: -E2 Option Motor and Feedback Pin Assignments ..... 27

Table 3-2: -E3 Option Motor and Feedback Pin Assignments ..... 28

Table 3-3: Feedback Specifications ..... 31

Table 3-4: HEX500-350HL Motor Specifications ..... 32

Table 3-5: HEX500-350HL Rotary Encoder Specifications ..... 32

Table 3-6: HEX500-350HL Linear Encoder Specifications (-E2 Option) ..... 32

Table 4-1: Grease Specifications ..... 38

*This page intentionally left blank.*

## Safety Procedures and Warnings

Read this manual in its entirety before installing, operating, or servicing this product. If you do not understand the information contained herein, contact an Aerotech representative before proceeding. Strictly adhere to the statements given in this section and other handling, use, and operational information given throughout the manual to avoid injury to you and damage to the equipment.

The following statements apply wherever the Warning or Danger symbol appears within this manual. Failure to observe these precautions could result in serious injury to those individuals performing the procedures and/or damage to the equipment.



**DANGER:** This product contains potentially lethal voltages. To reduce the possibility of electrical shock, bodily injury, or death the following precautions must be followed.

1. Access to the HEX500-350HL and component parts must be restricted while connected to a power source.
2. Do not connect or disconnect any electrical components or connecting cables while connected to a power source.
3. Disconnect electrical power before servicing equipment.
4. All components must be properly grounded in accordance with local electrical safety requirements.
5. Operator safeguarding requirements must be addressed during final integration of the product.
6. **PINCH POINT!** Keep Hands Clear while the stage is in motion.



**WARNING:** To minimize the possibility of electrical shock, bodily injury or death the following precautions must be followed.

1. Moving parts can cause crushing or shearing injuries. Access to all stage and motor parts must be restricted while connected to a power source.
2. Cables can pose a tripping hazard. Securely mount and position all system cables to avoid potential hazards.
3. Do not expose this product to environments or conditions outside of the listed specifications. Exceeding environmental or operating specifications can cause damage to the equipment.
4. The HEX500-350HL must be mounted securely. Improper mounting can result in injury and damage to the equipment.
5. Use care when moving the HEX500-350HL. Lifting or transporting the HEX500-350HL improperly can result in injury or damage to the HEX500-350HL.
6. This product is intended for light industrial manufacturing or laboratory use. Use of this product for unintended applications can result in injury and damage to the equipment.
7. If the product is used in a manner not specified by the manufacturer, the protection provided by the product can be impaired and result in damage, shock, injury, or death.
8. Operators must be trained before operating this equipment.
9. All service and maintenance must be performed by qualified personnel.

*This page intentionally left blank.*



## EU Declaration of Incorporation

**Manufacturer:** Aerotech, Inc.  
101 Zeta Drive  
Pittsburgh, PA 15238-2811  
USA

**herewith declares that the product:**

HEX500-350HL

*is intended to be incorporated into machinery to constitute machinery covered by the Directive 2006/42/EC as amended;*

*and that the following harmonized European standards have been applied:*

EN ISO 12100:2010

Safety of machinery - Basic concepts, general principles for design

EN 60204-1:2010

Safety of machinery - Electrical equipment of machines - Part 1: General requirements

*and further more declares that*

it is not allowed to put the equipment into service until the machinery into which it is to be incorporated or of which it is to be a component has been found and declared to be in conformity with the provisions of the Directive 2006/42/EC and with national implementing legislation, i.e., as a whole, including the equipment referred to in this Declaration.

***This is to certify that the aforementioned product is in accordance with the applicable requirements of the following Directive(s):***

2011/65/EU

RoHS 2 Directive

**Authorized Representative:** Simon Smith, European Director  
**Address:** Aerotech Ltd  
The Old Brick Kiln, Ramsdell, Tadley  
Hampshire RG26 5PR  
UK

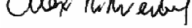
**Name**  / Alex Weibel  
**Position** Engineer Verifying Compliance  
**Location** Pittsburgh, PA  
**Date** 11/9/2018



*This page intentionally left blank.*

## Chapter 1: Overview

**NOTE:** Aerotech continually improves its product offerings; listed options may be superseded at any time. All drawings and illustrations are for reference only and were complete and accurate as of this manual's release. Refer to [www.aerotech.com](http://www.aerotech.com) for the most up-to-date information.

The **base** of a hexapod has a flat mounting surface on the bottom and holds electronics for the hexapod. The base should be mounted to a flat, rigid mounting surface (refer to [Section 2.3](#)). The **base joints** allow the attached strut to pivot from the base.

The **platform** is the moving plate of a hexapod. The threaded holes on the top surface are designed to hold customer equipment (refer to [Section 2.4](#)). The **platform joints** allow the attached strut to pivot from the platform.

The six **struts** of a hexapod change length in order to control the position of the platform. The struts attach only to the joints of the base and platform.

The **cables** exit out of the back of the base. These six cables connect the hexapod to the controller (refer to the [Section 3.2](#)).

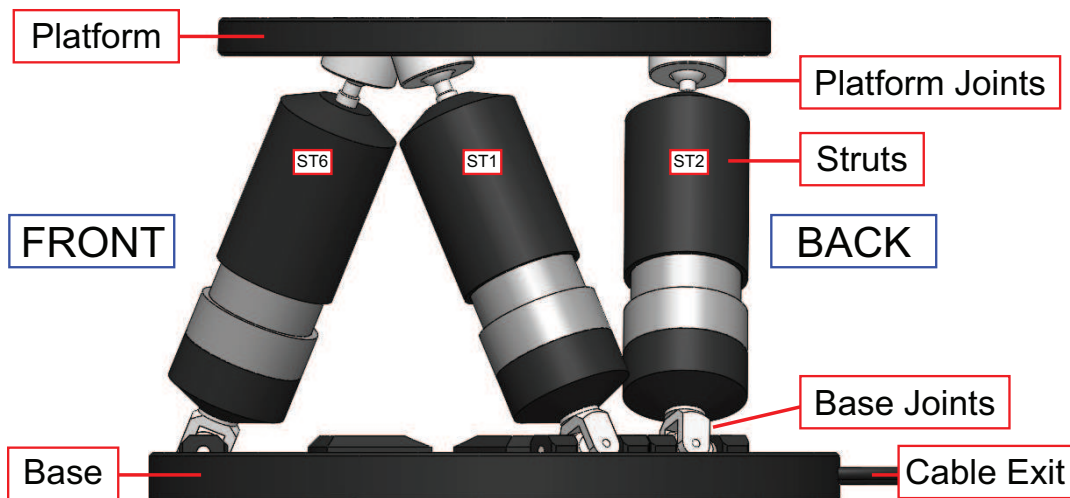

Figure 1-1: HEX500-350HL Callouts

Table 1-1: Model Options

HexGen® HEX500-350HL Hexapod 6-DOF Positioning System	
HEX500-350HL	Six degree-of-freedom hexapod positioning system; 500 mm diameter base; 350 mm height at mid-travel; high-load capacity version
Feedback (Required)	
-E2	Absolute encoders
-E3	Incremental encoders
Performance Grade (Optional)	
-PL3	Base performance
-PL4	Ultra high-accuracy performance
Customization	
Additional customization may be available (Vacuum preparation, custom geometry, etc.). Contact Aerotech for details.	

## 1.1. Environmental Specifications



**WARNING:** Do not expose this product to environments or conditions outside of the listed specifications. Exceeding environmental or operating specifications can cause damage to the equipment.

**Table 1-2: Environmental Specifications**

<b>Ambient Temperature</b>	Operating: 10° to 35° C (50° to 95° F) Deviation in temperature can result in performance degradation.
	Storage: 0° to 40° C (32° to 104° F) in original shipping packaging
<b>Humidity</b>	Operating: 20% to 60% RH
	Storage: 10% to 70% RH, non-condensing in original packaging. The machine should be packaged with desiccant if it is to be stored for an extended time.
<b>Altitude</b>	Operating: 0 m to 2,000 m (0 ft to 6,562 ft) above sea level Contact Aerotech if your specific application involves use above 2,000 m or below sea level.
<b>Vibration</b>	Use the system in a low vibration environment. Excessive floor or acoustical vibration can affect system performance. Contact Aerotech for information regarding your specific application.
<b>Protection Rating</b>	HexGen <sup>®</sup> hexapods have limited protection against particles. This equates to an Ingress Protection rating of IP30.
<b>Use</b>	Indoor use only

### 1.1.1. Accuracy and Temperature Effects

Aerotech products are designed for and built in a 20°C environment. Moderate temperature changes will affect the accuracy while extreme temperature changes could cause damage to the machine. At a minimum, the environmental temperature must be controlled to within 1°C per hour to ensure the safety of the hexapod. The severity of temperature effects on all specifications depends on many different environmental conditions, including how the hexapod is mounted. Contact the factory for more details.

## 1.2. Basic Specifications

**Table 1-3: HEX500-350HL Series Specifications**

			X	Y	Z	A (θx)	B (θy)	C (θz)
Travel <sup>(1)</sup>			100 mm	110 mm	54 mm	22°	22°	40°
Axis Positioning Accuracy <sup>(2,3)</sup>	Full Travel	Standard (-PL3)	±4 μm	±4 μm	±3 μm	±50 μrad (±10.3 arc-sec)	±50 μrad (±10.3 arc-sec)	±25 μrad (±5.2 arc-sec)
		ULTRA (-PL4)	±1 μm	±1 μm	±0.75 μm	±10 μrad (±2.1 arc-sec)	±10 μrad (±2.1 arc-sec)	±5 μrad (±1.0 arc-sec)
	Limited Travel <sup>(7)</sup>	Standard (-PL3)	±1.25 μm			±12.5 μrad (±2.6 arc-sec)	±12.5 μrad (±2.6 arc-sec)	±7.5 μrad (±1.5 arc-sec)
		ULTRA (-PL4)	±0.75 μm	±0.75 μm	±0.5 μm	±5 μrad (±1.0 arc-sec)	±5 μrad (±1.0 arc-sec)	±2.5 μrad (±0.5 arc-sec)
Resolution (Minimum Incremental Motion)			20 nm			0.2 μrad (0.04 arc sec)		
Bidirectional Repeatability, pk-pk <sup>(3)</sup>			±0.6 μm	±0.6 μm	±0.35 μm	±1 μrad (±0.2 arc sec)		
Unidirectional Repeatability, pk-pk			±0.25 μm	±0.25 μm	±0.15 μm	±0.5 μrad (±0.1 arc sec)		
Maximum Speed <sup>(4)</sup>			50 mm/s	50 mm/s	25 mm/s	10 °/s	10 °/s	20 °/s
Load Capacity, All Positions <sup>(5)</sup>	Vertical	200 kg (Push); 120 kg (Pull)						
	Horizontal	35 kg						
Holding Capacity, De-Energized <sup>(6)</sup>			165 kg					
Stage Mass			49 kg					
Material			Anodized Aluminum Platform and Base; Steel Used in Joints and Inside Struts					
<p>1. Travels are mutually-exclusive. Consult the HexGen<sup>®</sup> Hexapod Sizer on the Aerotech website for detailed workspace sizing.</p> <p>2. Measured with single-axis moves at a height of 50 mm above the moving platform. Results can be payload and workpoint dependent.</p> <p>3. X, Y, Z performance certified as standard. X, Y, Z, A, B, C performance certified with -PL4.</p> <p>4. Requires the selection of an appropriate amplifier with sufficient voltage and current.</p> <p>5. Centered loading (refer to <a href="#">Section 2.4.</a>).</p> <p>6. Horizontal base plate, centered loading (refer to <a href="#">Section 2.4.</a>).</p> <p>7. Over any 20 mm (X, Y, Z) or 5° (A, B, C)</p>								

## 1.3. Understanding Basic HEX500-350HL Operation

### 1.3.1. Hexapod Axes

The hexapod platform can be actuated in six degrees of freedom by changing the lengths of the six struts that connect the platform to the base. Since the axes of motion are not obvious from the mechanics of the hexapod, the axis convention is outlined below. These axes can be used to orient the hexapod in the global workspace. Refer to the HexGen<sup>®</sup> Programming Guide for more information about controlling hexapod motion. To get a copy of this guide, go to the Manuals, Help files, & Cable Drawings section of [www.aerotech.com](http://www.aerotech.com). Select the **Controllers** tab. Then download **User Guide for Hexapod Programming**.

The six axes include 3 translational axes, X, Y, and Z, and 3 rotational axes, A, B, and C. As shown in the overview, the cables exit out of the back of the base. The positive direction of the X axis goes to the right when looking at the front of the hexapod, and the Z axis goes up vertically. The Y axis goes toward the back of the hexapod. Rotational axes are oriented in the same direction as the translational axes, and positive rotation is clockwise when looking in the direction of the axis. The A axis rotates about the X axis, B rotates about the Y axis, and C rotates about Z. The control software enables the user to customize the coordinate system with certain restrictions. Please refer to the HexGen Programming guide for details regarding coordinate system manipulation.

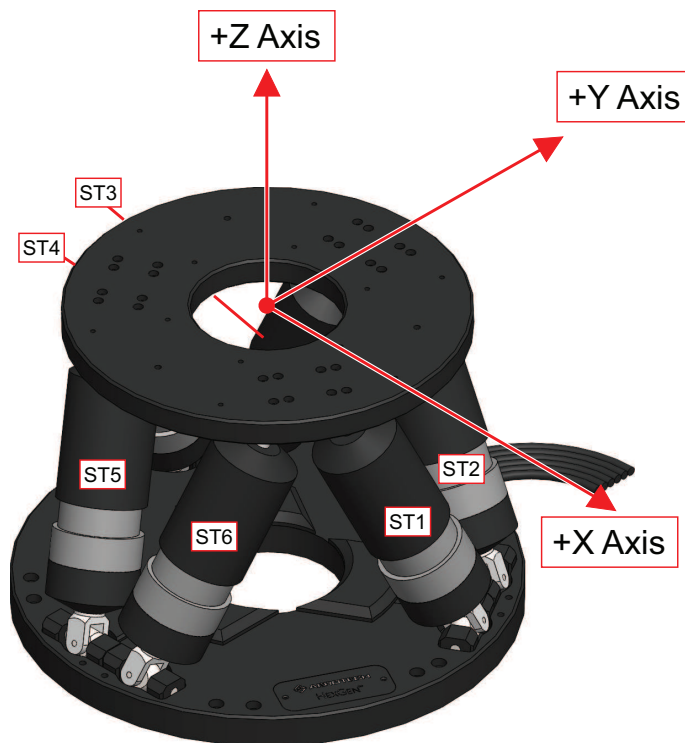

Figure 1-2: Axis Orientation

### 1.3.2. Strut Limits and Hexapod Range

Limits on the strut keep the strut within the useable travel range. When any strut has reached the end of travel in either direction, an error will occur in the controller. Because the ranges of the hexapod axes are interdependent, the limits of the hexapod axes are not constant, and the range of motion of a hexapod cannot be concisely described. Refer to [Section 1.2.](#) for the independent travel of each hexapod axis and the strut travel. If a strut limit is triggered, the hexapod is out of range. In this case, follow the directions of the controller to return the hexapod to a position within the range of motion. Refer to the HexGen<sup>®</sup> Programming Guide for more information.

### 1.3.3. Homing

When the incremental encoder option (-E3) is ordered, the struts must each be homed in order for the hexapod to be controlled. Knowledge of the initial condition is necessary for the inverse kinematic calculations to be accurate. The home sequence involves moving each strut to its shortest position and then returning to the center of travel. Be sure that there are no crash conditions before homing. Refer to the HexGen<sup>®</sup> Programming Guide for more information about initializing a hexapod.

If the absolute encoder option (-E2) has been ordered, there is no need to home the hexapod.

*This page intentionally left blank.*



## Chapter 2: Mechanical Specifications and Installation



**WARNING:** HEX500-350HL installation must be in accordance to instructions provided by this manual and any accompanying documentation. Failure to follow these instructions could result in injury or damage to the equipment.

### 2.1. Unpacking and Handling the Hexapod



**DANGER/HEAVY:** Manually lifting and moving the hexapod is not recommended. Refer to [Section 1.2](#) for mass specifications.

- Only lift by the lifting rings of the shipping brackets (refer to [Figure 2-1](#)).
- **Never** lift by the struts or joints.



**WARNING:** It is the customer's responsibility to safely and carefully lift the stage.

- Handle the struts and joints very carefully and do not apply force or torque directly to these components.
- Make sure that all moving parts are secure before moving the HEX500-350HL. Unsecured moving parts may shift and cause bodily injury.
- Improper handling could adversely affect the HEX500-350HL's performance. Use care when moving the HEX500-350HL.

**NOTE:** If any damage has occurred during shipping, report it immediately.

Carefully remove the HEX500-350HL from its protective shipping container. Gently set the HEX500-350HL on a smooth, flat, and clean surface.

Before operating the HEX500-350HL, it is important to let it stabilize at room temperature for at least 12 hours. Allowing it to stabilize to room temperature will ensure that all of the alignments, preloads, and tolerances are the same as they were when tested at Aerotech. Use compressed nitrogen or clean, dry, oil-less air to remove any dust or debris that has collected during shipping.

Each HEX500-350HL has a label listing the system part number and serial number. These numbers contain information necessary for maintaining or updating system hardware and software. Locate this label and record the information for later reference.

**Shipping Brackets**

Red, anodized aluminum shipping brackets have been installed to prevent unwanted motion and potential damage from occurring during shipment. The brackets must be removed before the HEX500-350HL can be operated. Retain the brackets and hardware for future use.

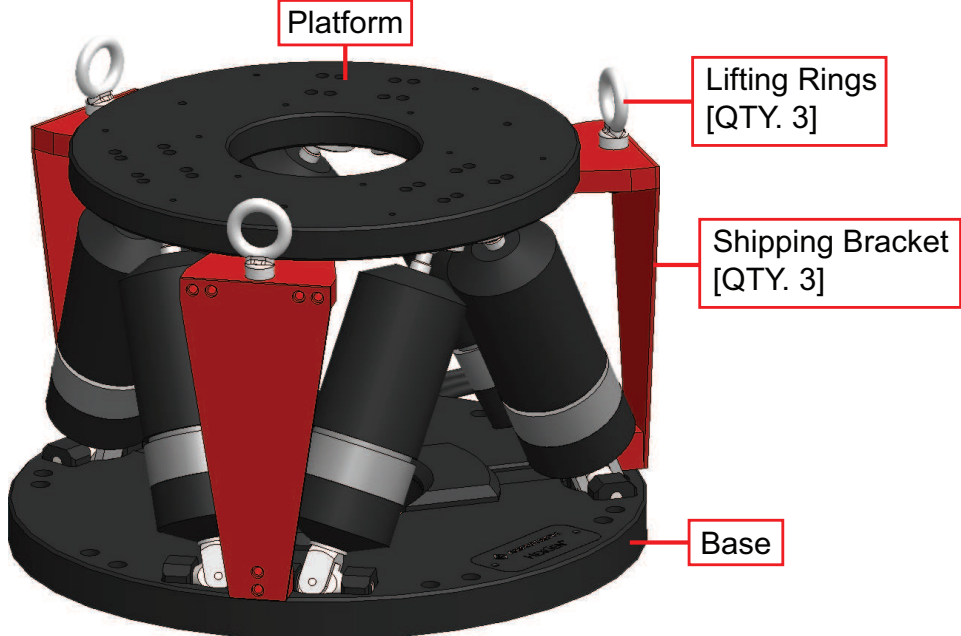

**Figure 2-1: Lifting and Shipping Brackets**

## 2.2. Dimensions

**NOTE:** Aerotech continually improves its product offerings; listed options may be superseded at any time. All drawings and illustrations are for reference only and were complete and accurate as of this manual's release. Refer to [www.aerotech.com](http://www.aerotech.com) for the most up-to-date information.

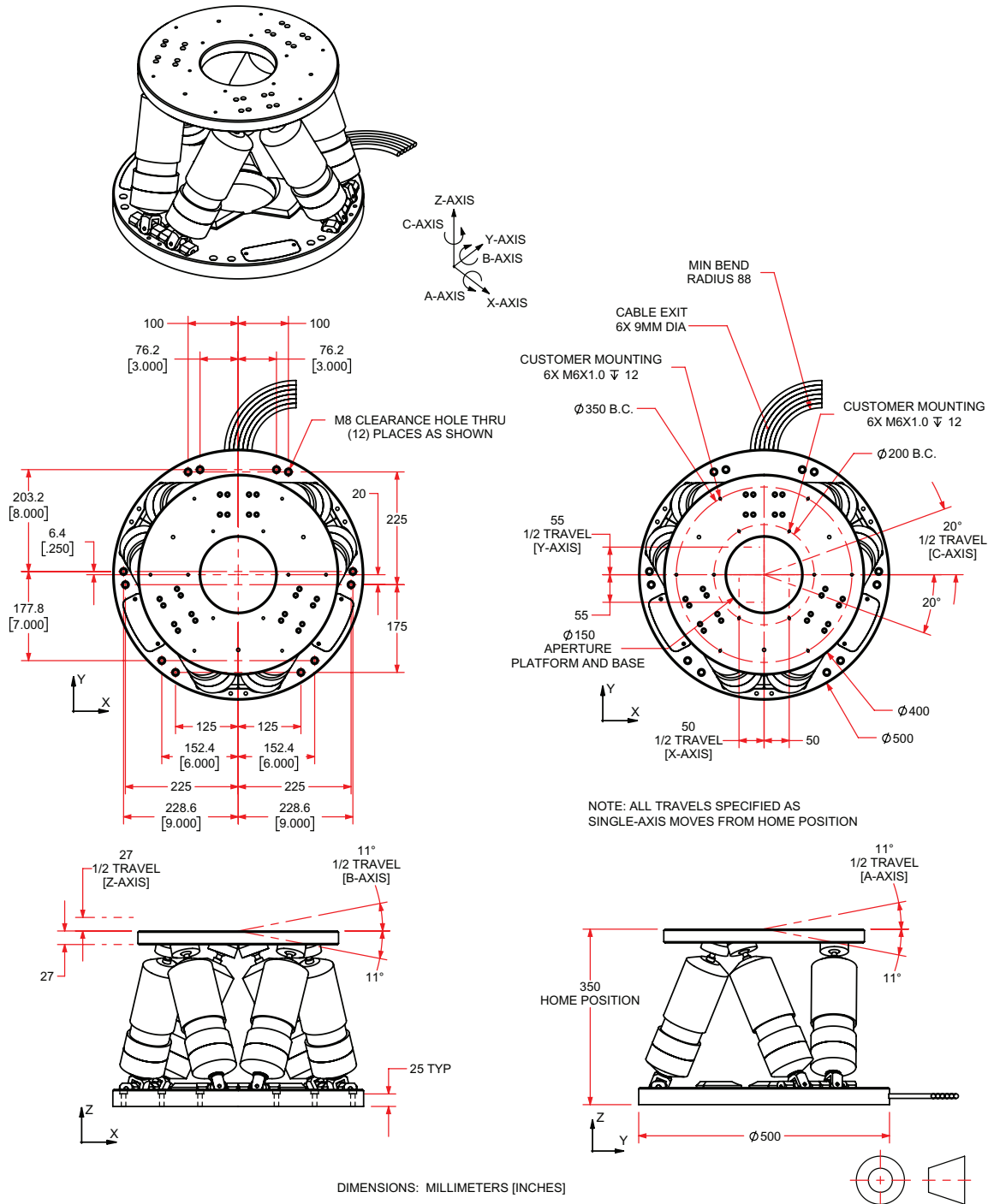

Figure 2-2: HEX500-350HL Dimensions

### 2.3. Securing the HEX500-350HL to the Mounting Surface



**WARNING:** The HEX500-350HL must be mounted securely. Improper mounting can result in injury and damage to the equipment.



**WARNING:** Make sure that all moving parts are secure before moving the HEX500-350HL. Unsecured moving parts may shift and cause bodily injury.

The mounting surface must be flat and have adequate stiffness in order to achieve the maximum performance from the HEX500-350HL stage. When it is mounted to a non-flat surface, the stage can be distorted as the mounting screws are tightened. This distortion will decrease overall accuracy. Adjustments to the mounting surface must be done before the stage is secured.

Inspect the mounting surface for dirt or unwanted residue and clean if necessary. Use precision flatstones on the mounting surface to remove any burrs or high spots. Clean the mounting surface with a lint-free cloth and acetone or isopropyl alcohol and allow the cleaning solvent to completely dry. Gently place the stage on the mounting surface.

**NOTE:** To maintain accuracy, the mounting surface must be flat to within 10  $\mu\text{m}$  per 100 mm.

**NOTE:** The HEX500-350HL is precision machined and verified for flatness prior to product assembly at the factory. If machining is required to achieve the desired flatness, it should be performed on the mounting surface rather than the HEX500-350HL. Shimming should be avoided if possible. If shimming is required, it should be minimized to retain maximum rigidity of the system.

A minimum of six M8 mounting screws are required to mount the hexapod to the mounting surface. Refer to [Figure 2-3](#) or [Section 2.2. Dimensions](#) for mounting locations and [Table 2-1](#) for tightening torque values.

Tightening torque values for the mounting hardware are dependent on the properties of the surface to which the stage is being mounted. Values provided in [Table 2-1](#) are typical values and may not be accurate for your mounting surface. Refer to [Section 2.2](#) for specific model mounting locations and dimensions.

**Table 2-1: Stage to Mounting Surface Hardware**

Mounting Hardware	Typical Screw Torque
M8 SHCS (12 places)	17 N·m

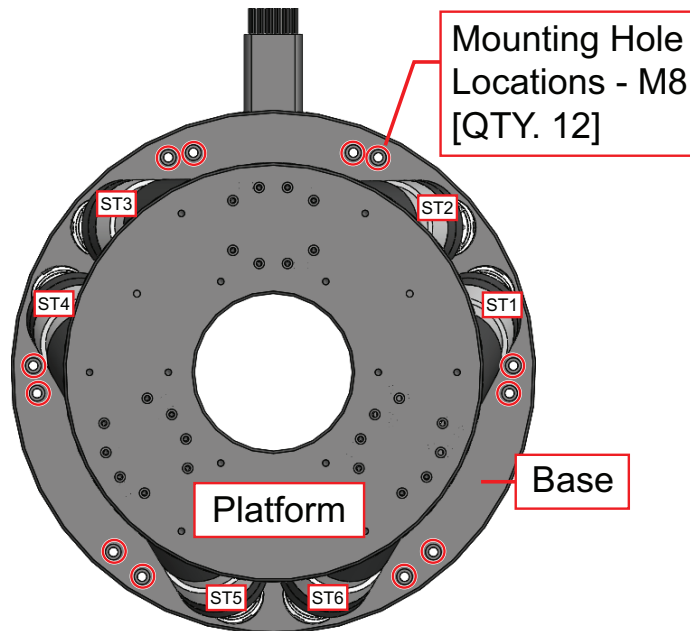

**Figure 2-3: Mounting Hole Locations**

## 2.4. Attaching the Payload to the HEX500-350HL

Inspect the mounting surface for dirt or unwanted residue and clean if necessary. Clean the mounting surface with a lint free cloth and isopropyl alcohol and allow the cleaning solvent to completely dry.

Aerotech recommends that customers use a representative payload during start-up to prevent accidental damage to the stage and the payload. Proceed with the electrical installation and test the motion control system in accordance with the system documentation. Document all results for future reference. For information on electrical installation refer to [Chapter 3](#) and the documentation delivered with the stage.

The payload must be flat, rigid, and comparable to the stage in quality to maintain optimum performance.

**NOTE:** For valid system performance, the mounting interface should be flat within 10  $\mu\text{m}$  over the contact area.

Loads should be mounted close to the center of the hexapod, if possible, to reduce offset loading. The maximum load is based on the distance from the payload’s center of mass to the center of the platform’s mounting surface. External forces to the payload or hexapod platform should be considered when determining the maximum payload. Add process forces to the mass of the payload when determining the total applied force.

HexGen<sup>®</sup> hexapods can be mounted to a horizontal surface or a vertical surface. The orientation will also be critical in determining the load capacity. A horizontal mounting surface is recommended for maximum payload capabilities. Refer to the load curves ([Figure 2-4](#) through [Figure 2-6](#)) for allowable loading as a function of orientation and load offset.

**NOTE:** HexGen<sup>®</sup> hexapods can backdrive under some vertical loads. These limits are described in [Figure 2-4](#).

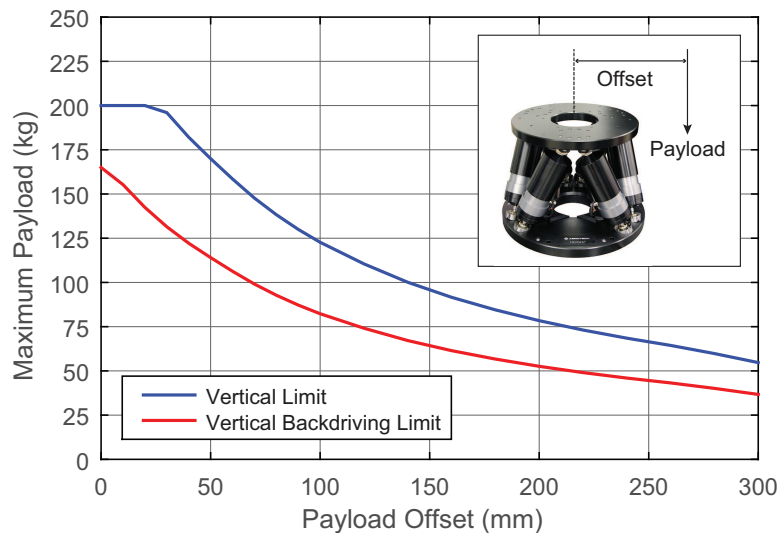

**Figure 2-4: HEX500-350HL Vertical Load Capabilities**

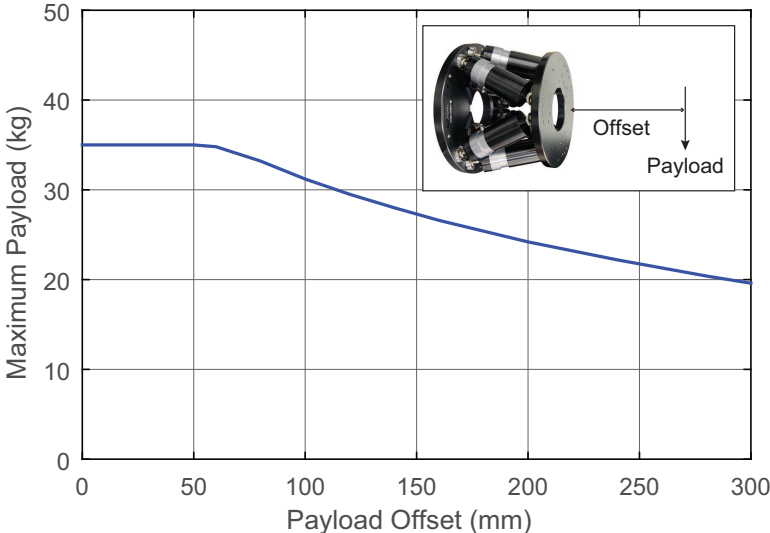

**Figure 2-5: HEX500-350HL Horizontal Load Capabilities**

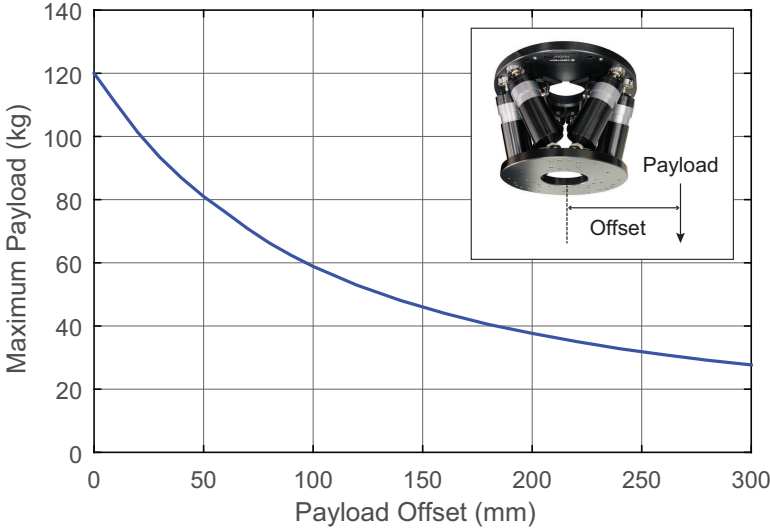

**Figure 2-6: HEX500-350HL Inverted Load Capabilities**

*This page intentionally left blank.*



## Chapter 3: Electrical Specifications and Installation



**WARNING:** Electrical installation must be performed by properly qualified personnel.

Electrical installation requirements will vary depending on product options. Installation instructions in this section are for HEX500-350HL stages equipped with standard Aerotech motors intended for use with an Aerotech motion control system. Contact Aerotech for further information regarding products that are otherwise configured.

Aerotech motion control systems are adjusted at the factory for optimum performance. When the HEX500-350HL is part of a complete Aerotech motion control system, setup usually involves connecting the HEX500-350HL to the appropriate drive chassis with the cables provided. Labels on the system components usually indicate the appropriate connections.

If system level integration was purchased, an electrical drawing showing system interconnects has been supplied with the system (separate from this documentation).

The electrical wiring from the motor and encoder are integrated at the factory. Refer to the sections that follow for standard motor wiring and connector pinouts.



**WARNING:** Applications requiring access to the stage while it is energized will require additional grounding and safeguards. The System Integrator or qualified installer is responsible for determining and meeting all safety and compliance requirements necessary for the integration of this stage into the final application.



**DANGER:** Remove power before connecting or disconnecting electrical components or cables. Failure to do so may cause electric shock or damage to the equipment.



**WARNING:** Operator access to the base and tabletop must be restricted while connected to a power source. Failure to do so may cause electric shock.

### 3.1. Motor and Feedback Connectors

Stages equipped with standard motors and encoders come from the factory completely wired and assembled.

**NOTE:** Refer to the other documentation accompanying your Aerotech equipment. Call your Aerotech representative if there are any questions on system configuration.

**NOTE:** If using standard Aerotech motors and cables, motor and encoder connection adjustments are not required.

The protective ground connection of the HEX500-350HL provides motor frame ground protection only. Additional grounding and safety precautions are required for applications requiring access to the stage while it is energized. The System Integrator or qualified installer is responsible for determining and meeting all safety and compliance requirements necessary for the integration of this stage into the final application.



**DANGER:** Remove power before connecting or disconnecting electrical components or cables. Failure to do so may cause electric shock or damage to the equipment.



**WARNING:** The protective ground connection must be properly installed to minimize the possibility of electric shock.



**WARNING:** Operator access to the base and tabletop must be restricted while connected to a power source. Failure to do so may cause electric shock.



**CAUTION:** The stage controller must provide over-current and over-speed protection. Failure to do so may result in permanent damage to the motor and stage components.

**Table 3-1: -E2 Option Motor and Feedback Pin Assignments**

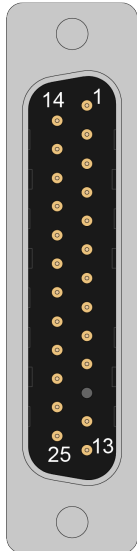
Pin	Description	Connector
1	Over-Temperature Thermistor sensor	
2	Cosine-N	
3	Sine-N	
4	Absolute Clock-	
5	Common	
6	Common	
7	Absolute Data-	
8	Reserved	
9	Reserved	
10	Hall Effect sensor, phase C	
11	Key	
12	Motor Phase A	
13	Motor Phase B	
14	Cosine	
15	Sine	
16	Absolute Clock+	
17	Encoder +5 V	
18	Stage ID	
19	Absolute Data+	
20	Reserved	
21	Reserved	
22	Hall Effect sensor, phase A	
23	Hall Effect sensor, phase B	
24	Frame/Safety Ground	
25	Motor Phase C	
Case	Signal shield connection (to case)	

Mating Connector	Aerotech P/N	Third Party P/N
Backshell	ECK00656	Amphenol 17E-1726-2
Connector	ECK00300	FCI DB25S064TLF

**Table 3-2: -E3 Option Motor and Feedback Pin Assignments**

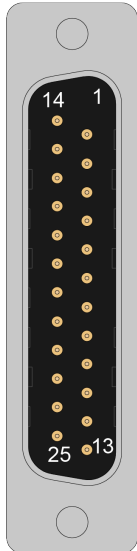
Pin	Description	Connector
1	Key (Ensures that correct cable is plugged into the correct jack)	
2	Cosine-N	
3	Sine-N	
4	Marker-N	
5	Common ground	
6	Common ground	
7	Negative (CCW) hardware limit	
8	Hall Effect sensor, phase A	
9	Hall Effect sensor, phase C	
10	Frame ground	
11	Motor Phase A	
12	Motor Phase B	
13	Motor Phase C	
14	Cosine	
15	Sine	
16	Marker	
17	+5 V supply input for feedback devices	
18	Reserved	
19	Positive (CW) hardware limit	
20	Motor Thermistor	
21	Hall Effect sensor, phase B	
22	Frame	
23	Motor Phase A	
24	Motor Phase B	
25	Motor Phase C	
Case	Signal shield connection (to case)	

Mating Connector	Aerotech P/N	Third Party P/N
Backshell	ECK00656	Amphenol 17E-1726-2
Connector	ECK00300	FCI DB25S064TLF

### 3.2. Motor and Feedback Wiring

All motor and controller manufacturers have their own designations for motor phases A/B/C and Hall signals A/B/C (refer to Section 3.5. for motor phasing). Shielded cables are required for the motor and feedback connections.

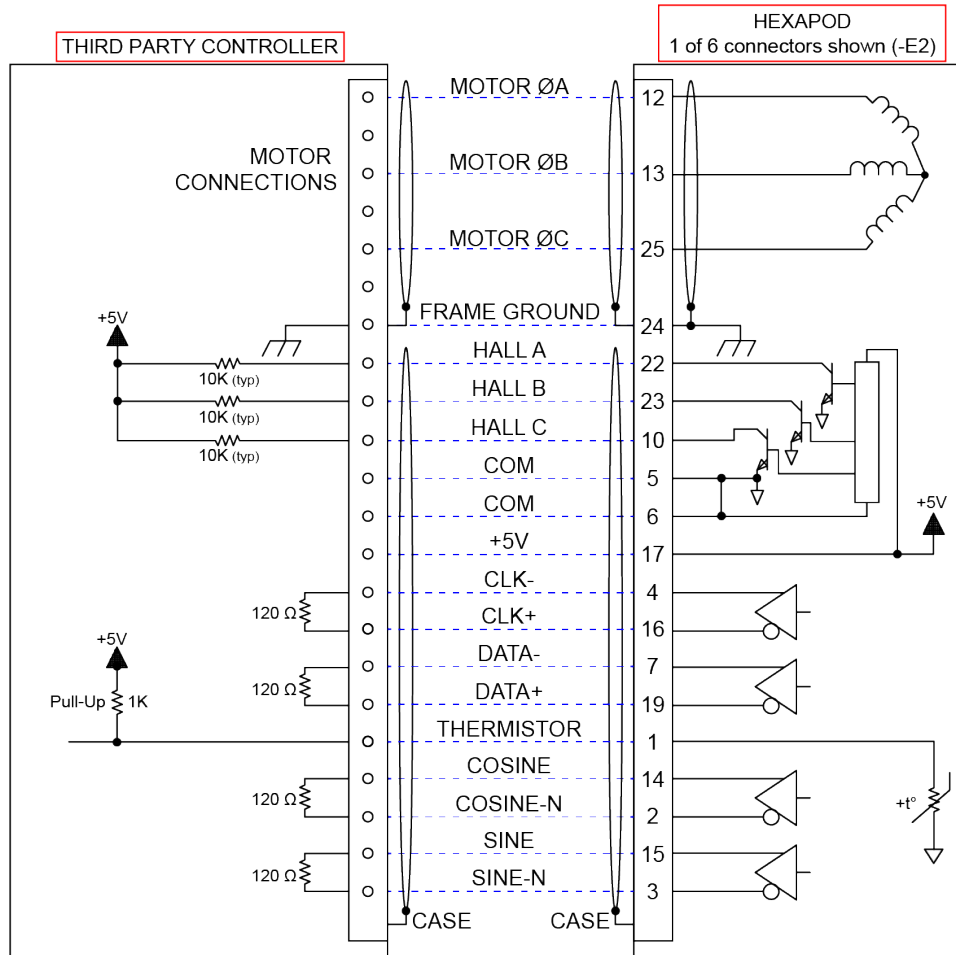

Figure 3-1: Motor and Feedback Wiring (-E2 Connector)

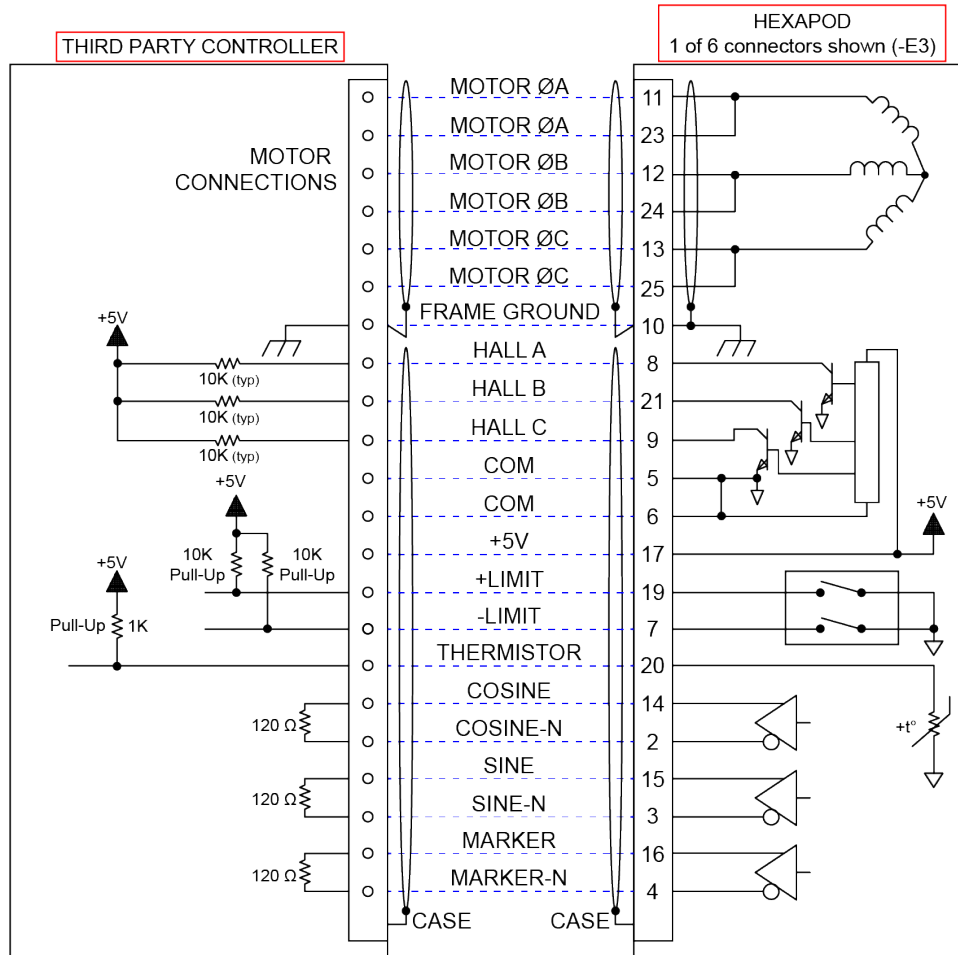

Figure 3-2: Motor and Feedback Wiring (-E3 Connector)

### 3.3. Motor and Feedback Specifications

**Table 3-3: Feedback Specifications**

Hall-Effect Sensors Specifications	
Supply Voltage	5 V $\pm$ 5%
Supply Current	50 mA
Output Type	Open Collector
Output Voltage	24 V max (pull up)
Output Current	5 mA (sinking)
Thermistor Specifications	
Polarity	Logic "0" (no fault)
	Logic "1" (over-temperature fault)
Cold Resistance	$\sim$ 100 $\Omega$
Hot Resistance	$\sim$ 10 K
<b>Note:</b> 1K pull-up to +5V recommended.	
Encoder Specifications for -E2 (-E3 plus a linear encoder) and -E3 (rotary encoder)	
Supply Voltage	5 V $\pm$ 10%
Supply Current	-E2 425 mA
	-E3 175 mA
Output Signals	-E2 <b>Sinusoidal Type (Incremental Rotary Encoder):</b> 1 V <sub>pk-pk</sub> into 120 $\Omega$ load (differential signals SIN+, SIN-, COS+, and COS-) <b>Serial Output (Absolute Linear Encoder):</b> Biss C (unidirectional)
	-E3 <b>Sinusoidal Type (Incremental Rotary Encoder):</b> 1 V <sub>pk-pk</sub> into 120 $\Omega$ load (differential signals SIN+, SIN-, COS+, and COS-)
Limit Switch Specifications	
Supply Voltage	5 V
Supply Current	25 mA
Output Type	Open Collector
Output Voltage	5 V
Output Current	10 mA (sinking)
Output Polarity	Normally Closed (NC) <ul style="list-style-type: none"> <li>Sinks current to ground (Logic "0") when not in limit</li> <li>High impedance (Logic "1") when in limit</li> <li>Requires external pull-up to +5 V (10 k<math>\Omega</math> recommended)</li> </ul>
<b>Notes:</b> <ul style="list-style-type: none"> <li>If the HEX500-350HL is driven beyond the electrical limit, it will encounter a mechanical stop. Impacting the mechanical stop could cause damage to the stage even at low speeds.</li> </ul>	

**Table 3-4: HEX500-350HL Motor Specifications**

		S-76-35
<b>Performance Specifications (1,5)</b>		
Winding Designation		-A
Stall Torque, Cont. (2)	N·m	0.48
Peak Torque (3)	N·m	1.92
<b>Electrical Specifications (5)</b>		
Winding Designation		-A
BEMF Const., line-line, Max	$V_{pk}/krpm$	29.1
Continuous Current, Stall (2)	$A_{pk}$	2.0
	$A_{rms}$	1.4
Peak Current, Stall (2)	$A_{pk}$	8.0
	$A_{rms}$	5.7
Torque Constant (4, 9)	$N·m/A_{pk}$	0.24
	$N·m/A_{rms}$	0.34
Motor Constant (2, 4)	$N·m/\sqrt{W}$	0.075
Resistance, 25°C, line-line	$\Omega$	10.5
Inductance, line-line	mH	1.40
Maximum Bus Voltage	$V_{DC}$	80
Thermal Resistance	°C/W	1.83
Number of Poles	--	14
<p>1. Performance is dependent upon heat sink configuration, system cooling conditions, and ambient temperature</p> <p>2. Values shown @ 75°C rise above a 25 °C ambient temperature, with housed motor mounted to a 250 mm x 250 mm x 6 mm aluminum heat sink</p> <p>3. Peak force assumes correct rms current; consult Aerotech.</p> <p>4. Torque constant and motor constant specified at stall</p> <p>5. All performance and electrical specifications <math>\pm 10\%</math></p> <p>6. Specifications given are for the motor only. When integrated into a housing with bearings additional losses should be considered.</p> <p>7. Maximum winding temperature is 100 °C (thermistor trips at 100 °C)</p> <p>8. Ambient operating temperature range 0 °C - 25 °C; consult Aerotech for performance in elevated ambient temperatures</p> <p>9. All Aerotech amplifiers are rated <math>A_{pk}</math>; use torque constant in <math>N·m/A_{pk}</math> when sizing</p>		

**Table 3-5: HEX500-350HL Rotary Encoder Specifications**

	Fundamental Signal Period
Fundamental Resolution	3,600 Lines/Rev

**Table 3-6: HEX500-350HL Linear Encoder Specifications (-E2 Option)**

	Fundamental Signal Period
Fundamental Resolution	1 nm



### 3.4. Machine Direction

Aerotech stages are configured to have positive and negative "machine" directions. The machine direction defines the phasing of the feedback and motor signals and is dictated by the stage wiring (refer to [Section Chapter 1](#) for Motor and Feedback phasing information). Programming direction of a stage is set by the controller that is used to move the stage. Programming direction is typically selectable in the controller, while machine direction is hardwired in the stage. [Figure](#) shows the machine direction of HEX500-350HL stages.

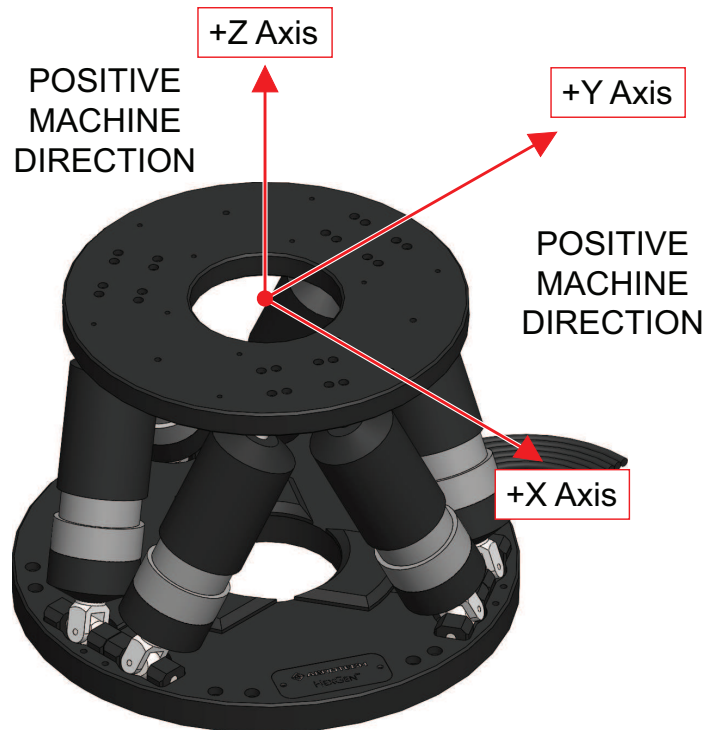
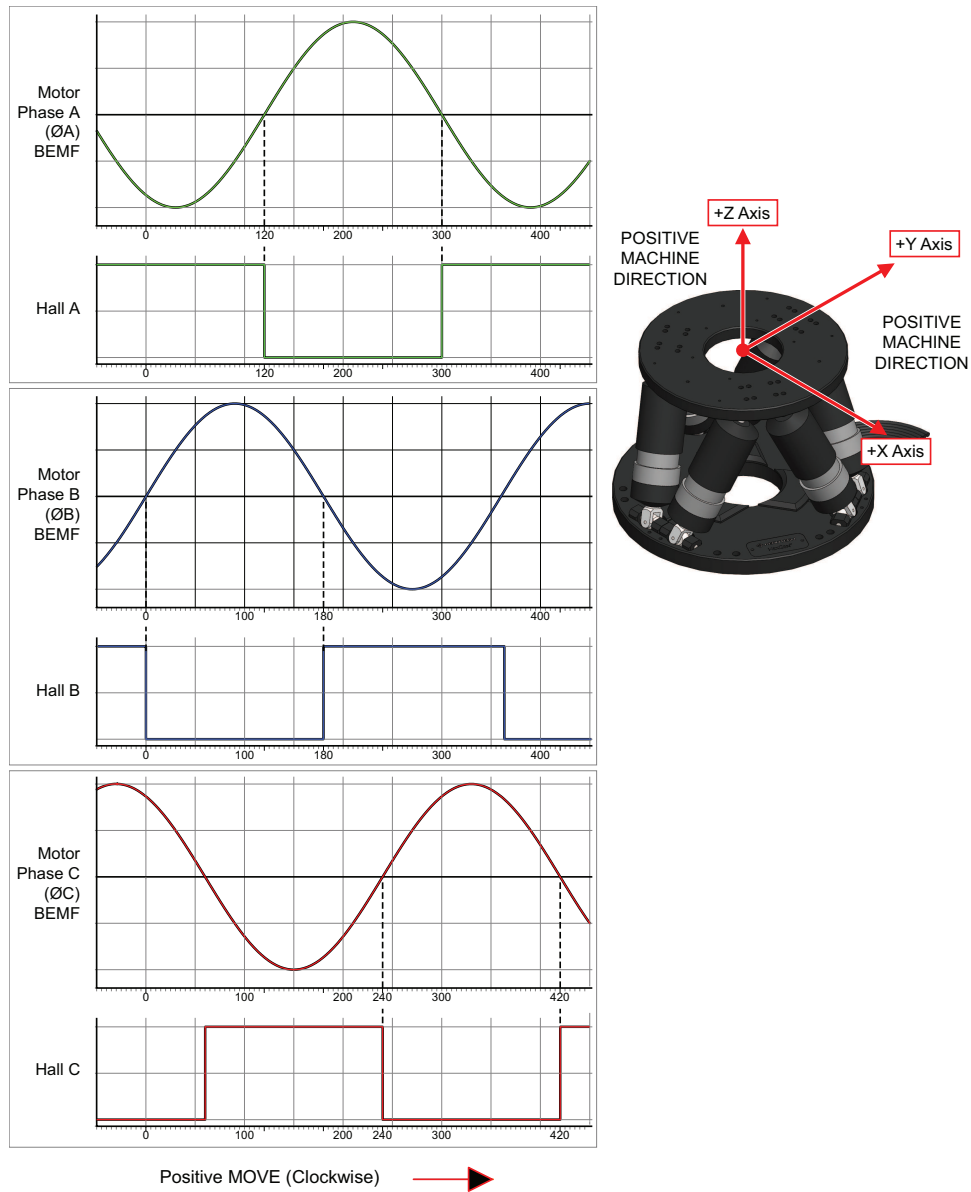

Figure 3-3: Machine Direction

### 3.5. Motor and Feedback Phasing

Motor phase voltage is measured relative to the virtual wye common point.



**Figure 3-4: Hall Phasing**

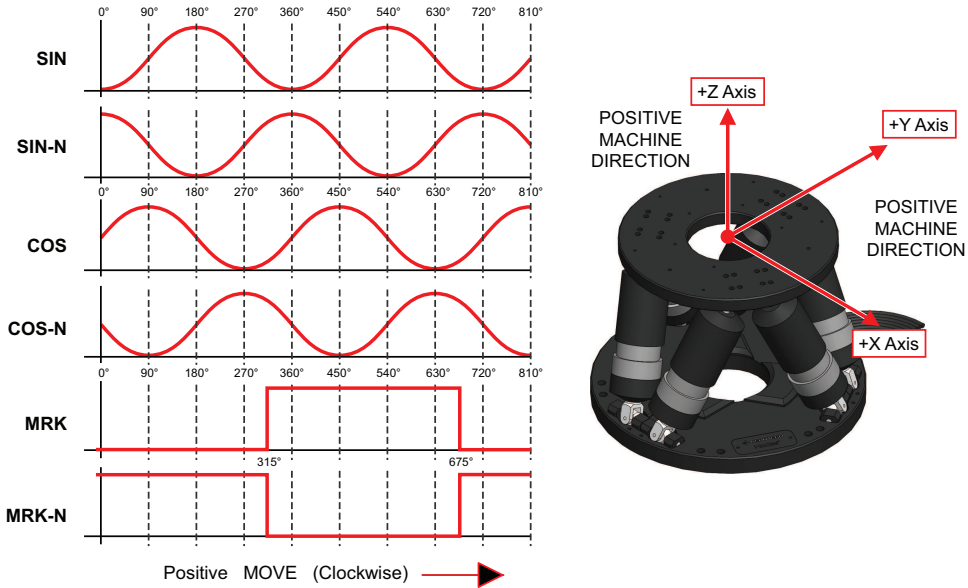

**Figure 3-5: Encoder Phasing Reference Diagram (Standard)**

*This page intentionally left blank.*

## Chapter 4: Maintenance



**DANGER:** To minimize the possibility of bodily injury or death, disconnect all electrical power prior to performing any maintenance or making adjustments to the equipment.



**DANGER: PINCH POINT!** Keep Hands Clear while the stage is in motion.

### 4.1. Service and Inspection Schedule

Inspect and clean the HEX500-350HL once per month. A longer or shorter inspection interval may be required depending on the specific application, and conditions such as the duty cycle, speed, and environment.

Monthly inspections should include but not be limited to:

- Re-tighten loose connectors.
- Replace or repair damaged cables.
- Clean the HEX500-350HL and any components and cables as needed.
- Repair any damage before operating the HEX500-350HL.

## 4.2. Cleaning and Lubrication



**DANGER:** To minimize the possibility of bodily injury or death, disconnect all electrical power prior to performing any maintenance or making adjustments to the equipment.



**WARNING:** Be careful not to scratch any bearing surfaces when cleaning or lubricating the hexapod.

### Cleaning

Before using a cleaning solvent on any part of the HEX500-350HL, blow away small particles and dust with nitrogen or, less preferably, clean, dry, compressed air.

Any external metal surface of the HEX500-350HL can be cleaned with isopropyl alcohol on a lint-free cloth.

### Lubrication

Only use the grease specified in table as other greases may be incompatible.

**Table 4-1: Grease Specifications**

Location	Grease
Ballscrew	NSK LG2
Linear Rail	THK AFF
Angular Contact Bearings	Kluberplex BEM 34-132

If the application process uses only a small portion of travel for most of the duty cycle, periodically drive the stage through full travel to redistribute the lubrication in the bearings. The motor is completely non-contact and requires no lubrication.

### 4.3. Troubleshooting

Symptom	Possible Causes and Solutions
Strut will not move	<b>A Cable is Disconnected:</b> Check the cables for connections and damage.
	<b>Limit or Controller Fault:</b> Check the controller for faults. Refer to the controller and software documentation.
Strut moves uncontrollably	<b>Encoder Signal Connection</b> or the <b>Motor Signal Connection:</b> Check to make sure that the cable connections are secure. Refer to the <a href="#">Section 3.2. Motor and Feedback Wiring</a>
Axes are unstable or squeal	<b>Incorrect Gains:</b> Refer to controller documentation

*This page intentionally left blank.*



## Appendix A: Warranty and Field Service

Aerotech, Inc. warrants its products to be free from harmful defects caused by faulty materials or poor workmanship for a minimum period of one year from date of shipment from Aerotech. Aerotech's liability is limited to replacing, repairing or issuing credit, at its option, for any products that are returned by the original purchaser during the warranty period. Aerotech makes no warranty that its products are fit for the use or purpose to which they may be put by the buyer, whether or not such use or purpose has been disclosed to Aerotech in specifications or drawings previously or subsequently provided, or whether or not Aerotech's products are specifically designed and/or manufactured for buyer's use or purpose. Aerotech's liability on any claim for loss or damage arising out of the sale, resale, or use of any of its products shall in no event exceed the selling price of the unit.

THE EXPRESS WARRANTY SET FORTH HEREIN IS IN LIEU OF AND EXCLUDES ALL OTHER WARRANTIES, EXPRESSED OR IMPLIED, BY OPERATION OF LAW OR OTHERWISE. IN NO EVENT SHALL AEROTECH BE LIABLE FOR CONSEQUENTIAL OR SPECIAL DAMAGES.

### Return Products Procedure

Claims for shipment damage (evident or concealed) must be filed with the carrier by the buyer. Aerotech must be notified within thirty (30) days of shipment of incorrect material. No product may be returned, whether in warranty or out of warranty, without first obtaining approval from Aerotech. No credit will be given nor repairs made for products returned without such approval. A "Return Materials Authorization (RMA)" number must accompany any returned product(s). The RMA number may be obtained by calling an Aerotech service center or by submitting the appropriate request available on our website ([www.aerotech.com](http://www.aerotech.com)). Products must be returned, prepaid, to an Aerotech service center (no C.O.D. or Collect Freight accepted). The status of any product returned later than thirty (30) days after the issuance of a return authorization number will be subject to review.

Visit <https://www.aerotech.com/global-technical-support.aspx> for the location of your nearest Aerotech Service center.

### Returned Product Warranty Determination

After Aerotech's examination, warranty or out-of-warranty status will be determined. If upon Aerotech's examination a warranted defect exists, then the product(s) will be repaired at no charge and shipped, prepaid, back to the buyer. If the buyer desires an expedited method of return, the product(s) will be shipped collect. Warranty repairs do not extend the original warranty period.

**Fixed Fee Repairs** - Products having fixed-fee pricing will require a valid purchase order or credit card particulars before any service work can begin.

**All Other Repairs** - After Aerotech's evaluation, the buyer shall be notified of the repair cost. At such time the buyer must issue a valid purchase order to cover the cost of the repair and freight, or authorize the product(s) to be shipped back as is, at the buyer's expense. Failure to obtain a purchase order number or approval within thirty (30) days of notification will result in the product(s) being returned as is, at the buyer's expense.

Repair work is warranted for ninety (90) days from date of shipment. Replacement components are warranted for one year from date of shipment.

### Rush Service

At times, the buyer may desire to expedite a repair. Regardless of warranty or out-of-warranty status, the buyer must issue a valid purchase order to cover the added rush service cost. Rush service is subject to Aerotech's approval.

### On-site Warranty Repair

If an Aerotech product cannot be made functional by telephone assistance or by sending and having the customer install replacement parts, and cannot be returned to the Aerotech service center for repair, and if Aerotech determines the problem could be warranty-related, then the following policy applies:

Aerotech will provide an on-site Field Service Representative in a reasonable amount of time, provided that the customer issues a valid purchase order to Aerotech covering all transportation and subsistence costs. For warranty field repairs, the customer will not be charged for the cost of labor and material. If service is rendered at times other than normal work periods, then special rates apply.

If during the on-site repair it is determined the problem is not warranty related, then the terms and conditions stated in the following "On-Site Non-Warranty Repair" section apply.

### On-site Non-Warranty Repair

If any Aerotech product cannot be made functional by telephone assistance or purchased replacement parts, and cannot be returned to the Aerotech service center for repair, then the following field service policy applies:

Aerotech will provide an on-site Field Service Representative in a reasonable amount of time, provided that the customer issues a valid purchase order to Aerotech covering all transportation and subsistence costs and the prevailing labor cost, including travel time, necessary to complete the repair.

### Service Locations

<http://www.aerotech.com/contact-sales.aspx?mapState=showMap>

<b>USA, CANADA, MEXICO</b>	<b>CHINA</b>	<b>GERMANY</b>
Aerotech, Inc. Global Headquarters Phone: +1-412-967-6440 Fax: +1-412-967-6870	Aerotech China Full-Service Subsidiary Phone: +86 (21) 5508 6731	Aerotech Germany Full-Service Subsidiary Phone: +49 (0)911 967 9370 Fax: +49 (0)911 967 93720
<b>JAPAN</b>	<b>TAIWAN</b>	<b>UNITED KINGDOM</b>
Aerotech Japan Full-Service Subsidiary Phone: +81 (0)50 5830 6814 Fax: +81 (0)43 306 3773	Aerotech Taiwan Full-Service Subsidiary Phone: +886 (0)2 8751 6690	Aerotech United Kingdom Full-Service Subsidiary Phone: +44 (0)1256 855055 Fax: +44 (0)1256 855649

Have your customer order number ready before calling.

# Appendix B: Revision History

Revision	Description
1.01.00	Updated encoder specifications
1.00.00	New Manual

*This page intentionally left blank.*

# Index

			<b>I</b>	
	-		Incremental Encoder	31
-E2 Option Encoder		31	inspect	37
	<b>2</b>		Inspection Schedule	37
2010		9	Inverted Load Capabilities	23
	<b>A</b>		isopropyl alcohol	38
Absolute Encoder		31	<b>L</b>	
Altitude		12	label	17
Ambient Temperature		12	Limit Switch Specifications	31
Attaching the Payload		22	Linear Encoder Specifications	31
	<b>B</b>		load capacity	22
backdriv		22	Lubrication	38
	<b>C</b>		<b>M</b>	
cleaning			Mounting Hole Locations	21
mounting surface		20	mounting surface	
solvents		38	cleaning	20
Cleaning		38	securing stage	20
	<b>D</b>		<b>P</b>	
Digital Output Encoder		31	part number	17
	<b>E</b>		Performance Specifications	
Electrical Specifications			S-76	32
S-76		32	Protection Rating	12
EN 60204-1		9	protective ground connection	26
EN ISO 12100		9	<b>R</b>	
Encoder Specifications		31	Rotary Encoder	31
	<b>G</b>		<b>S</b>	
Global Technical Support		2	S-76	
	<b>H</b>		Electrical Specifications	32
Hall-Effect Sensors Specifications		31	Performance Specifications	32
Horizontal Load Capabilities		23	serial number	17
Humidity		12	Serial Output Encoder	31
			Service and Inspection Schedule	37

---

shimming	20
solvents	38
stabilizing stage	17
stage	
distortion	20
stabilizing	17
Support	2
	<b>T</b>
Technical Support	2
Thermistor Specifications	31
	<b>V</b>
Vertical Load Capabilities	22
Vibration	12
	<b>W</b>
Warranty and Field Service	41